

Possible applications

Examples for buttonhole applications

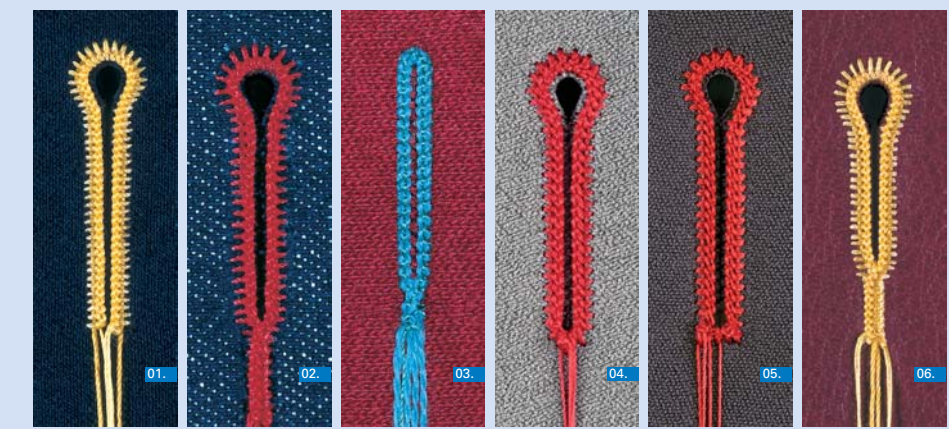

01. 559-151 E1501 / 580-121 E 1201 / 580-151 E1501
Buttonhole with eye up to 5 mm width; cut after sewing; with lower gimp; needle thread: NM 70/3 to NM 120/2; looper thread: NM 70/3 to NM 120/2; gimp thread: NM 30/3; applications: men's wear, ladies' wear, sportswear.

02. 559-151 E1573 / 580-141 E 1423
Buttonhole with eye and taper bar; 5 to 8 mm width; cut after sewing; with lower gimp; needle thread: NM 70/3 to NM 120/2; looper thread: NM 70/3 to NM 120/2; gimp thread: NM 30/3; applications: jeans and sportswear, with special upper cloth clamps for jeans waistbands.

03. 559-151 E1504 / 580-121 E1204
Buttonhole with taper bar; without eye; up to 5 mm width; cut after sewing; without gimp; needle thread: NM 70/3 to NM 120/2; looper thread: NM 70/3 to NM 120/2; applications: for flexible and elastic material, e.g. knitwear.

04. 559-151 E1521
Buttonhole with eye and round tack; from 5 to 8 mm width; cut after sewing; with lower gimp; needle thread: NM 70/3 to NM 120/2; looper thread: NM 70/3 to NM 120/2; gimp thread: NM 30/3; applications: men's wear, ladies' wear, sportswear.

05. 559-151 E1521
Buttonhole with eye and cross tack; from 5 to 8 mm width; cut after sewing; without gimp; needle thread: NM 70/3 to NM 120/2; looper thread: NM 70/3 to NM 120/2; gimp thread: NM 30/3; applications: men's wear, ladies' wear, sportswear.

06. 559-151 E1521 with supplementary kit 0580 590734
Buttonhole with eye and taper bar; from 5 to 8 mm width; cut after sewing; with lower gimp; needle thread: NM 70/3 to NM 120/2; looper thread: NM 70/3 to NM 120/2; gimp thread: NM 30/3; applications: with supplementary kit 0580 590734 for the processing of garment leather.

07. 580-112 E1101
Buttonhole with eye and round tack; up to 5 mm width; cut after sewing; without gimp; needle thread: NM 70/3 to NM 120/2; looper thread: NM 70/3 to NM 120/2; applications: men's wear, ladies' wear, sportswear.

08. 580-112 E1121
Buttonhole with eye and cross tack; up to 5 mm width; cut after sewing; without gimp; needle thread: NM 70/3 to NM 120/2; looper thread: NM 70/3 to NM 120/2; applications: men's wear, ladies' wear, sportswear.

09. 580-112 E1151
Buttonhole with eye and round tack; up to 5 mm width; cut after sewing; without gimp; needle thread: NM 70/3 to NM 120/2; looper thread: NM 70/3 to NM 120/2. Adjustable start position: buttonhole start and finish are positioned shortly below the eye, this results in a perfectly neat round tack. Applications: men's wear, ladies' wear, sportswear.

10. 558-331391 E3312 / 559-151 E1501 / 580-121 E1201 / 580-151 E1501
Buttonhole with eye; without tack; cut after sewing; buttonhole width: max. 5 mm; with lower gimp; needle thread: NM 70/3 to NM 120/2; looper thread: NM 70/3 to NM 120/2; gimp thread: NM 30/3; applications: lapel buttonholes in men's jackets, coats and blazers.

11. 580-221 „FLEXCUT“ E1201
Buttonhole with eye, without tack; cut after sewing; buttonhole width: max. 5 mm; with lower gimp; needle thread: NM 70/3 to NM 120/2; looper thread: NM 70/3 to NM 120/2; gimp thread: NM 30/3; applications: buttonholes in coats, jackets, blazers – lapels and fronts. „FLEXCUT“ – variable cut length without manual block change – long buttonhole.

12. „FLEXCUT“ – variable cut length without manual block change – short buttonhole.

13. 580-121 E1221 with supplementary kit 0580 590734
Buttonhole with eye, without tack; from 5 to 8 mm width; cut after sewing; with lower gimp; needle thread: NM 70/3 to NM 120/2; looper thread: NM 70/3 to NM 120/2; gimp thread: NM 30/3; applications: with supplementary kit 0580 590734 for the processing of garment leather.

14. 558-341391 E3407 / 580-141 E1421
Buttonhole with eye and taper bar; from 5 to 8 mm width; cut after sewing; with lower gimp; needle thread: NM 60/2; looper thread: NM 60/2; gimp thread: NM 30/3; applications: decorative - effect buttonhole for sportswear and safety wear.

15. 558-341391 E3417 / 580-141 E1423
Buttonhole with eye and taper bar, from 5 to 8 mm width; cut after sewing; with lower gimp; needle thread: NM 60/2; looper thread: NM 60/2; gimp thread: NM 30/3; applications: jeans and sportswear.

16. 558-331391 E3312 / 559-151 E1501 / 580-151 E1501
Buttonhole without eye; with taper bar; up to 5 mm width; cut after sewing; with lower gimp; needle thread: NM 60/2; looper thread: NM 60/2; gimp thread: NM 30/3; applications: jeans and sportswear.

17. 558-331391 E3311 / 559-151 E1504 / 580-151 E1504
Buttonhole without eye; with taper bar; up to 5 mm width; cut after sewing; without gimp; needle thread NM 70/3; looper thread: "wool thread"; applications: for flexible and elastic material, e.g. knitwear.

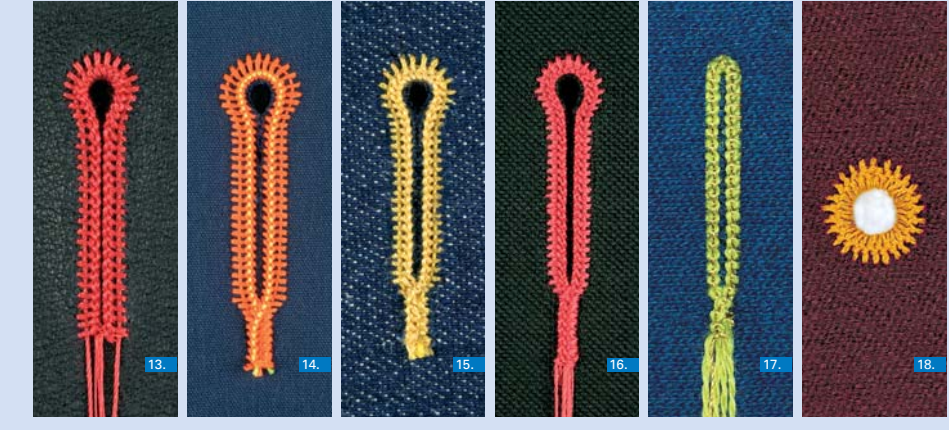
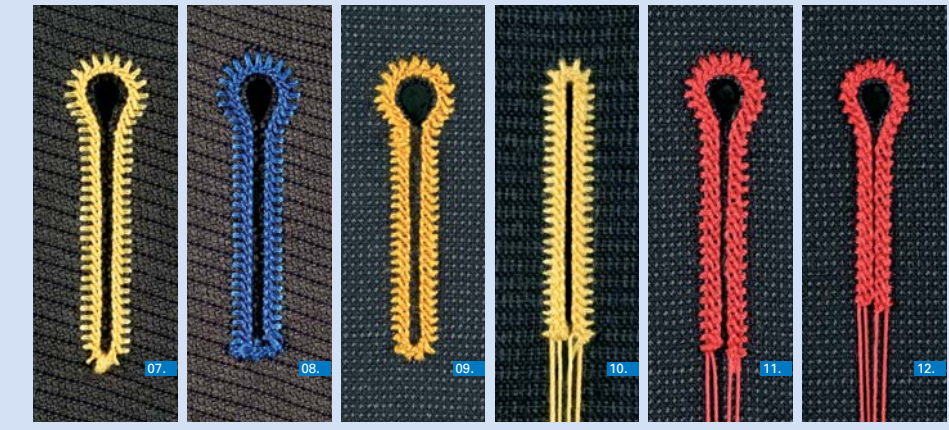

Optional equipments

Supplementary kits

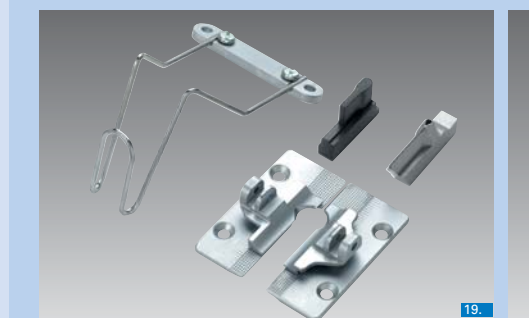

Supplementary Kit 0580 591034 "Hip Pockets" - for 580-112 facilitates easier positioning of hip pockets; consisting of a fabric deflector, upper and lower cloth clamps, a cutting block (cut length 18 mm) and a buttonhole knife; max. sewing length 26 mm.

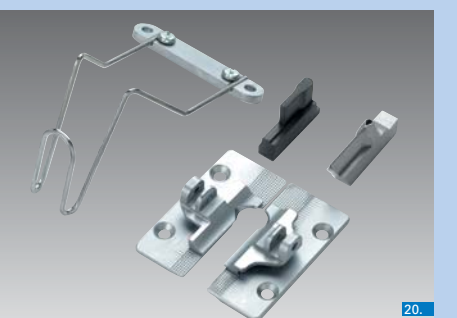

Supplementary Kit 0580 590584 "Hip Pockets" - for 559-151 facilitates easier positioning of hip pockets; consisting of a fabric deflector, upper and lower cloth clamps, a cutting block (cut length 18 mm) and a buttonhole knife; max. sewing length 26 mm.

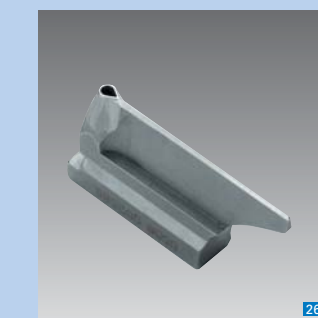

Supplementary Kit 0580 590754 "Small Eye" - for an eye size of 2,1 x 3,2 mm; cut length max. 38 mm; consisting of a buttonhole knife.

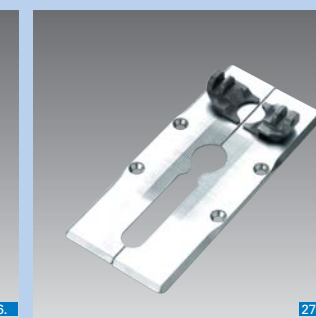

Supplementary Kit 0580 590854 "Round Eyelets with 580-112" - for round eyelets in 2-thread chain-stitch; 1 to 5 mm dia.; cut packages to be ordered separately; consisting of r/h and l/h upper cloth clamps.

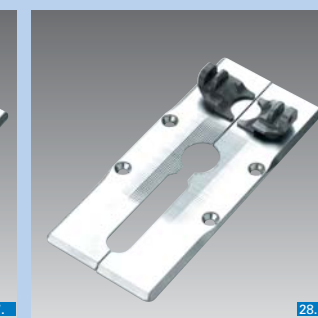

Supplementary Kit 0580 590864 "Round Eyelets with 580-112" - for round eyelets in 2-thread chain-stitch; 5 to 7 mm dia.; cut packages to be ordered separately; consisting of r/h and l/h upper cloth clamps.

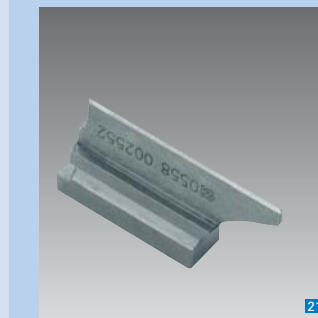

Supplementary Kit 0580 590704 "Without Eye" - for buttonholes without eye; consisting of a buttonhole knife; max. cut length 42 mm.

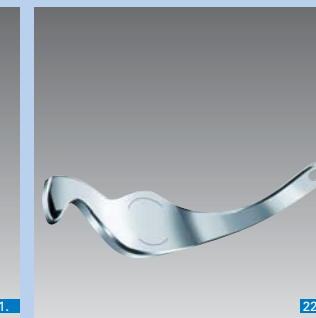

Supplementary Kit 0580 590714 "Narrow Buttonhole" - for buttonhole width max. 5 mm; for the conversion of E-groups "wide" buttonhole to "narrow" buttonhole; consisting of a l/h spreader. Lower cloth clamps must be ordered separately, depending on the E-group.

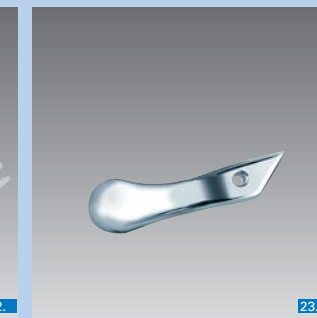

Supplementary Kit 0580 590724 "Relief Type Buttonhole" - facilitates the use of looper threads NM 30/3 and similar; consisting of a l/h looper.

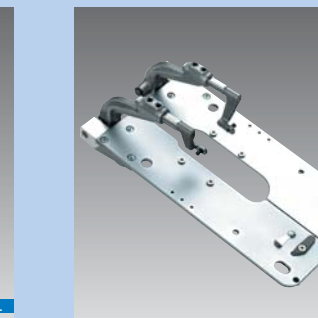

Supplementary Kit 0580 591194 "Clamping Plates 580-151" - for rapid change between e.g. buttonholes and round eyelets; consisting of r/h and l/h clamping plates. Upper and lower cloth clamps must be ordered separately.

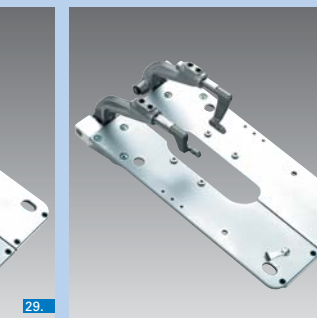

Supplementary Kit 0580 591204 "Clamping Plates 580-112" - for rapid change between e.g. buttonholes and round eyelets; consisting of r/h and l/h clamping plates. Upper and lower cloth clamps must be ordered separately.

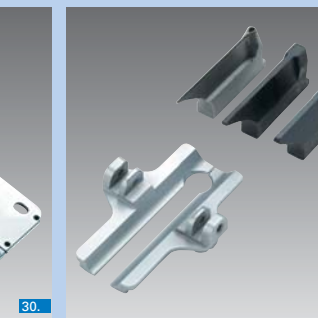

Supplementary Kit 0580 591024 "Long Buttonhole" - for cut lengths up to max. 50 mm; consisting of two upper cloth clamps, a buttonhole knife and two cutting blocks 46 and 50 mm.

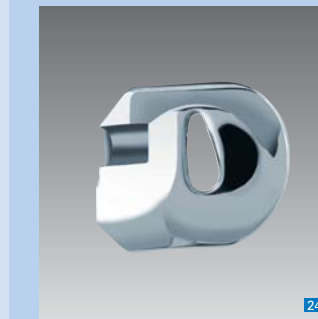

Supplementary Kit 0580 590734 "Buttonholes in Leather Garments" - for processing garment leather; consisting of a mushroom-shaped throat plate.



Supplementary Kit 0580 590744 "Buttonholes in Poplin" - avoids the rolling effect in fine and densely woven fabric; especially suitable for cutting mode "cut before"; consisting of a throat plate. Sewing result l/h: without, r/h with supplementary kit.

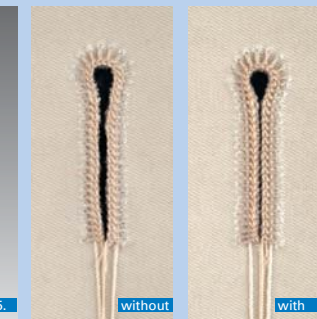

Supplementary Kit 0580 590804 "Upper Gimp" - upper gimp guide for added stability of buttonholes in knitwear; consisting of two upper and lower cloth clamps, a throat plate and a buttonhole knife.

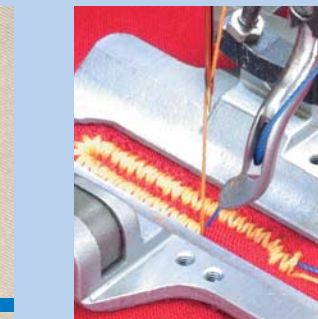

Supplementary Kit 0580 591174 "Buttonholes in Knitwear" - for 580-121; especially for buttonholes without eye in flexible and elastic material; consisting of two upper and lower cloth clamps, a throat plate and a buttonhole knife.

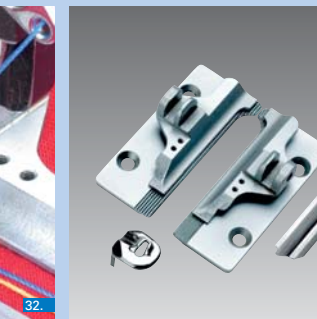

Supplementary Kit 0580 591184 "Buttonholes in Knitwear" - for 580-151; especially for buttonholes without eye in flexible and elastic material; consisting of two upper and lower cloth clamps, a throat plate and a buttonhole knife.

Positioning aids



Assembly Kit 0580 591224 "Centering Device" - for precise central positioning of buttonholes in hip pockets; consisting of two adjustable spacers and a mounting kit.



Assembly Kit 0580 590574 "Fabric Deflector for Hip Pockets" - for 580-141; easier positioning of hip pockets; consisting of a fabric deflector and a mounting kit.

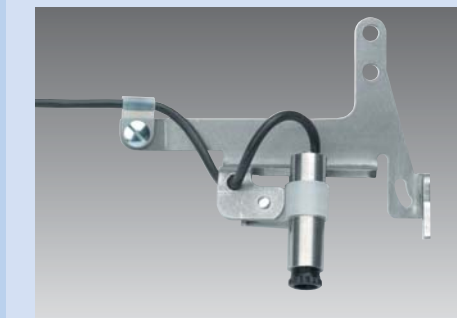

Assembly Kit 0580 590564 "Laser Marking Light" - for easy and precise positioning of the material; a laser line marks the buttonhole centre; a dot in the laser line marks the buttonhole eye; consisting of the laser marking light and a mounting kit.



Assembly Kit 0580 590604 "Additional Table" - for easier handling of jackets and coats with parallel buttonholes; consisting of the additional table with mounting kit. Only suitable with stand MG58 400114.

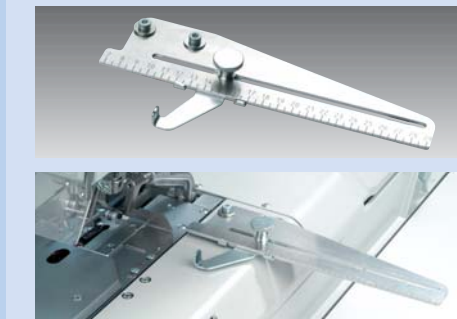

Assembly Kit 0580 590294 "Spacer for the distance between the buttonholes" - for 580-121; can be used on the r/h or on the l/h side; consisting of the spacer and a mounting kit.



Assembly Kit 0580 590504 "Rest Table" - for standing operation and easier handling of jackets and coats, especially for multi-machine workstations; consisting of the rest table and a mounting kit.

Further optional extras

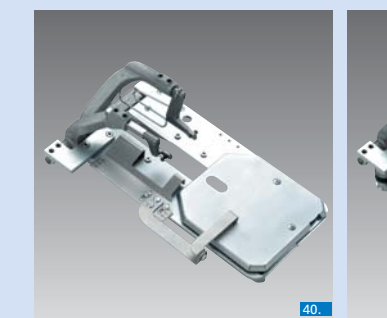

Assembly Kit 0580 590374 "Parallel Buttonholes" - for 580-121, clamping plates r/h + l/h for buttonholes parallel to the fabric edge. Upper and lower cloth clamps must be ordered separately, depending on the E-group.

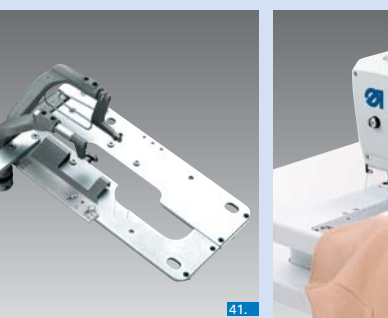

Assembly Kit 0580 590554 "Parallel Buttonholes" - for 580-151, clamping plates r/h + l/h for buttonholes parallel to the fabric edge. Upper and lower cloth clamps must be ordered separately, depending on the E-group.



Assembly Kit 0580 590604 "Additional Table" - for easier handling of jackets and coats with parallel buttonholes; consisting of the additional table with mounting kit. Only suitable with stand MG58 400114.



Assembly Kit 0580 100344 "Integrated Sewing Light" - for 559-151; patented, integrated cool light for brilliant and shadow-free illumination of the sewing area. Standard feature for series 580.

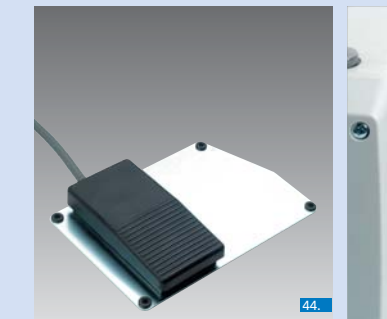

Assembly Kit 9880 580002 "Foot Switch" - for activating the clamp functions and the sewing cycle; consisting of the foot switch, a mounting bracket and a cable.



Standard feature 559-151 - the operation panel with numerical display allows easy access to the buttonhole programs.



Standard feature 580 - the operation panel features a large graphical display with clear user guidance and facilitates easiest programming. All buttonhole parameters can be easily identified and modified.

PRODUCT RANGE Automatic Eyelet Buttonholers



