

Preface and General Safety Information

Part 1: Operating Instructions Cl. 381 - 382

1.	Product Description	5
2.	Proper Use	5
3.	Subclasses	6
4.	Optional Equipment	6
5.	Technical Data	7
6.	Operation	
6.1	Threading the Needle Thread	9
6.2	Setting the Needle Thread Tension	11
6.3	Opening the Needle Thread Tension	11
6.4	Setting the Tension Regulator	12
6.5	Winding the Underthread	13
6.6	Inserting the Underthread Bobbin	14
6.7	Setting the Underthread Tension	15
6.8	Inserting and Changing Needles	16
6.9	Lifting the Sewing Feet	17
6.10	Arresting the Sewing Feet in the High Position	17
6.11	Setting the Sewing Foot Pressure	18
6.12	Stitch Length on Sewing Machines without Automatic Bartacking	19
6.12.1	Stitch Length on Sewing Machines with Automatic Bartacking	20
6.13	Switching the Needle Bars On and Off	21
6.14	Roller Top Feed	22
7.	Controls and Control Panel	
7.1	General	23
7.2	Keys on the Control Panel	24
7.3	Changing the Parameter Values	25
7.4	"Operator Level" Parameter List	26
7.5	Key Bank on the Machine Arm	27
8.	Sewing	28

9.	Maintenance	
9.1	Cleaning and Inspection	30
9.2	Oil Lubrication	33
10.	Optional Equipment	
10.1	Thread Wiper	34



1. Product Description

The **DÜRKOPP ADLER 381 - 382** are special sewing machines for first-class two-needle decorative seams.

- Two-needle flat bed double-saddle-stitch machine with bottom and needle feed. The needles can be turned on and off.
- Class **382** additionally with roller top feed.
- Slit presser bar (international standard), thus allowing normal commercial sewing devices to be used.
- Existing sewing devices of class 380 can be used.
- Central oil wick lubrication with visible reserve in the arm. Manual hook lubrication.
- Integrated winder.
- Integrated adjustment disk.

2. Proper Use

The **381 - 382** are special sewing machines which can properly be used for sewing light sewing material. Such material is, as a rule, fabric composed of textile fibers or leather. These sewing materials are used in the garment and furniture industries.

Furthermore, it may be possible to also execute so-called technical seams with this special sewing machine. Here, however, the operator (**DÜRKOPP ADLER AG** would be pleased to help) must make an evaluation of the possible dangers since such applications are, on the one hand, relatively rare and, on the other, their variety is immense. Depending on the results of this evaluation it may be necessary to adopt appropriate safety measures.

In general, only dry material may be worked with this special machine. The material may not be thicker than 8 mm when it is pressed together by the lowered sewing feet. The material may contain no hard objects because otherwise the sewing unit could only be allowed to be operated with eye protection.

Such eye protection is not available at this time.

The seam is generally made with sewing yarns of textile fibers with dimensions up to 30/2 Nm (synthetic threads) or 30/3 Nm (core spun threads). Those wishing to use other threads must also first evaluate the dangers arising herefrom and, if necessary, take safety measures.

This special sewing machine may only be installed and operated in dry and clean areas. If the sewing unit is employed in other areas, which are not dry and clean, other, to be agreed upon, measures may become necessary (see EN 60204-3-1: 1990).

We, as a manufacturer of industrial sewing machines, assume that, at a minimum, semi-skilled operating personnel work on our products so that all normal operations and, where applicable, their dangers can be presumed to be known.



3. Subclasses

- Cl. 381 - 160161:** Two-needle flat bed double-saddle-stitch machine with switchable needles, bottom and needle feed, electromagnetic thread trimmer.
- Cl. 381 - 160162:** as Cl. 381 - 160161, additionally with electropneumatic automatic bartacking and electropneumatic sewing foot lift.
- Cl. 382 - 160162:** as Cl. 381 - 160162, additionally with roller top feed

4. Optional Equipment

Order no.	Optional Equipment
9822 510001	Sewing light (halogen) WALDMANN, with 12V/20W lamp, to be attached to the sewing machine head.
OAPP 1241	Sewing light mounting kit, for 9822 510001.
0798 500088	Sewing light transformer For 230V, with mains cable, without switch, for sewing lights 9822 510001.
9780 000108	Maintenance unit WE 8 For pneumatic optional equipment.
0797 003031	Pneumatic connection package For the pneumatic connection of frames with maintenance unit and pneumatic optional equipment. Consisting of connection hose (length 5 m, diameter 9 mm), hose nozzles, hose clamps, coupling socket and coupling plug.
0381 590014	Electromagnetic thread wiper for Cl. 381
0382 590014	Electromagnetic thread wiper for Cl. 382
N900 001941	Swing rail for apparatus
N900 011038	Edge stop-right, on base plate, fixed
N900 012015	Edge stop-right, on base plate, swing-down
N900 020039	Edge stop-right, on the sewing machine head, swing-up



5. Technical Data

Noise level: Work station relevant emission value
to DIN 45635-48-A-1-KL2

Cl. 381 - 160161 Lc = __ dB (A)
Stitch length: __ mm
Number of stitches: 3 000 [min-1]
Material: _____

Cl. 381 - 160162 Lc = ___ dB (A)
Stitch length: __ mm
Number of stitches: 3 000 [min-1]
Material: _____

Cl. 382 - 160162 Lc = __ dB (A)
Stitch length: __ mm
Number of stitches: 3 000 [min-1]
Material: _____

The values were not available at press time !



Needle system:		797
Needle thickness (depending on E no.): [Nm]		(70 to 110) 90
Seam width / needle clearance: (depending on E no.)	[mm]	4.8 11.9 (25.4)
Max. sewing thread thicknesses: - Synthetic sewing thread - Core spun thread	[Nm] [Nm]	30/2 30/3
Max. number of stitches:	[min ⁻¹]	3 000 *
Max. stitch length: - Forward: - Reverse:	[mm] [mm]	(2 400 stitches/min) 6 * (2 400 stitches/min) 6 *
Max. sewing foot stroke:	[mm]	10 (Cl. 381) 9 (Cl. 382)
Feed dog stroke: (above the needle plate)	[mm]	1.1
Max. opening under the sewing feet: - Sewing - Raised	[mm] [mm]	8 10
Operating pressure:	[bar]	6
Air consumption per work cycle: approx. [NL]		0.02
Design voltage:		1 x 230 V, 50 / 60 Hz
Dimensions (H x W x D): (depending on table top)	[mm]	1750 x 1060 x 500 1750 x 1060 x 600 1750 x 1250 x 900
Work height (ex works):	[mm]	790
Weight (only machine head): approx.[kg]		40

* At max. stitch length the number of stitches must be reduced to 2 400 stitches/min.



6. Operation

6.1 Threading the Needle Thread



Caution Risk of Injury !

Turn the main switch off !
Thread the needle thread only with the sewing machine turned off.

- Place the yarn spools on the yarn stand as shown in the illustration and guide the needle and underthreads through the take-off arms. The take-off arms 1 and 3 must lie vertically above the yarn spools. The take-off arms 2 and 4 are to be set as per the drawing. They prevent the two needle threads from hitting each other.
- Thread the needle thread as per the drawing on **page 10**.

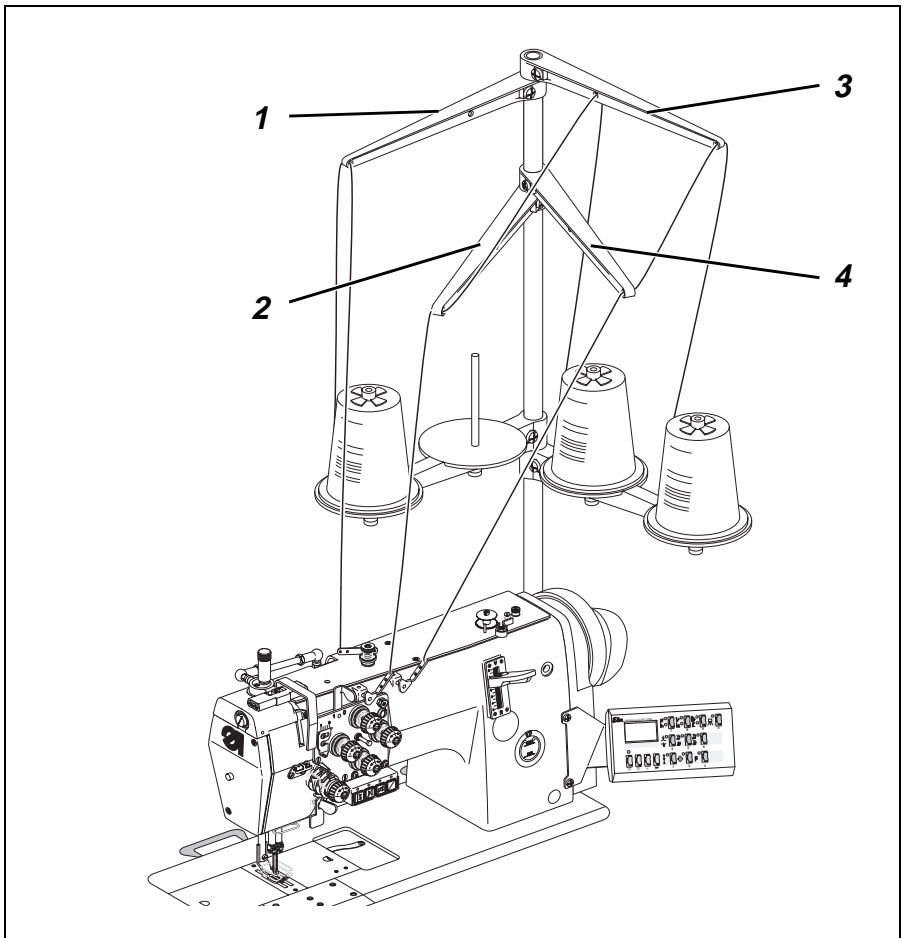

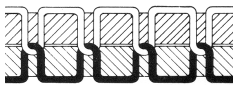
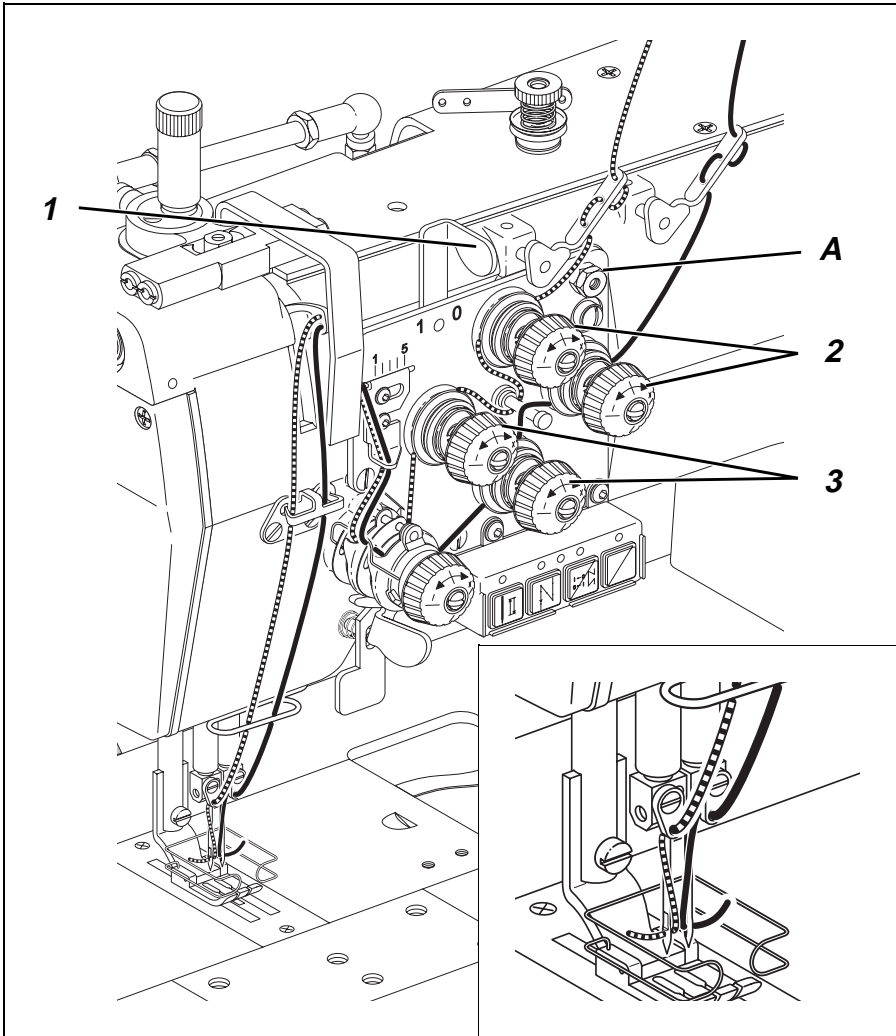

Illus. a: Correct thread interlacing in the middle of the material



Illus. b: Needle thread tension too low
or
Underthread tension too high



Illus. c: Needle thread tension too high
or
Underthread tension too low



6.2 Setting the Needle Thread Tension

Main tension 3

The main tension 3 is to be set as low as possible.

The interlacing of the threads should lie in the middle of the material (see Illus. a).

Too high thread tensions can lead to unwanted bunching in thin material and thread breakage.

- Set the main tension 3 so that a uniform stitch pattern is achieved.

Supplimentary tension 2

The switchable supplementary tension 2 serves for the quick change of the needle thread tension, e.g. at seam thickenings.

- Set the supplementary tension 2 lower than the main tension 3.
- Turn the supplementary tension 2 on or off with lever 1.
 - 0 = Supplementary tension 2 is turned off.
 - 1 = Supplementary tension 2 is turned on.

6.3 Opening the Needle Thread Tension

Automatic

The needle thread tension is automatically opened during thread trimming.

Note

The timing of the thread tension opening can be set with the parameters F-191 and F-192 (technician level).

Manual

The main and supplementary tensions can be opened by hand through pressure on **A**.



6.4 Setting the Tension Regulator

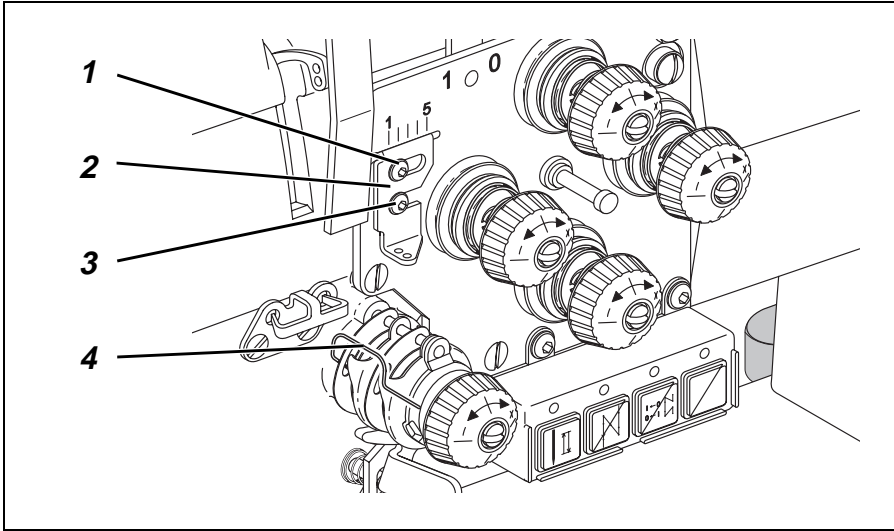

The needle thread quantity required for the hook is adjusted with the tension regulator 2.

The setting is dependent on the following factors:

- Material thickness
- Yarn characteristics
- Stitch length

A precisely set tension regulator assures an optimal sewing result at the lowest possible needle thread tension.

With a correct setting, the needle thread loop must glide over the thickest point of the hook with little tension.

In position " 1 " of the tension regulator the maximum thread quantity is released.

In position " 5 " of the tension regulator the minimum thread quantity is released.



Caution Risk of Injury !

Set tension regular 2 only with the sewing machine turned off.

- Loosen screws 1 and 3.
- Alter the position of the tension regulator 2.
The scale above the tension regulator serves as a setting aid.
- Tighten screws 1 and 3.

Setting note:

For a correct setting of the tension regulator 2 the following condition must be met:

- When the greatest thread quantity is required, the thread controller spring 4 must be pulled approx. 0.5 mm up out of its upper end position.
This is the case when the needle thread loop passes the maximum diameter of the hook.



6.5 Winding the Underthread

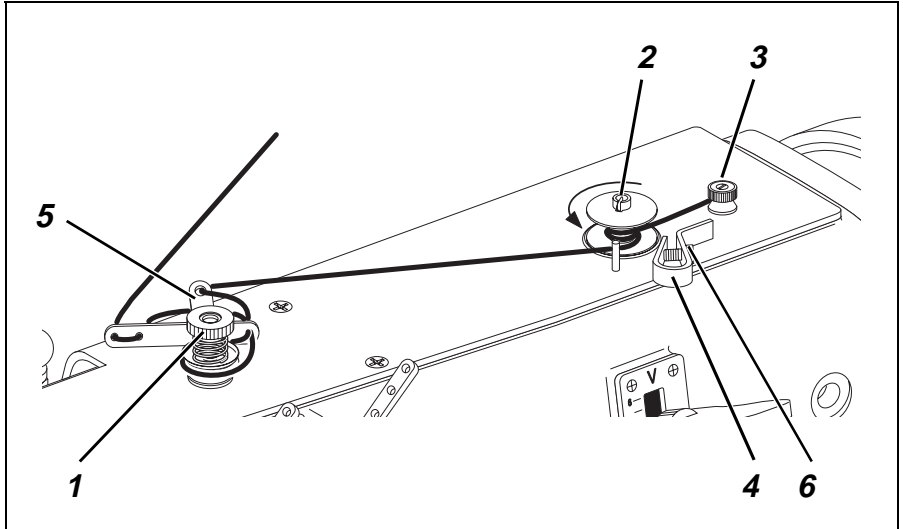

- Thread the underthread as shown in the illustrations.
- Place the bobbin on the winder shaft 2.
- Wind the underthread counterclockwise approx. 5x around the bobbin core.
- Tear off the underthread at thread clamp 3.
- Swing the winder lever 4 against the bobbin.
- Set the tension 1.
The underthread should be wound up uniformly with little tension.
- Bend the guide plate 5.
The bobbin should be filled cylindrically and not conically.
- Set screw 6.
The winder should shut off automatically at the correct time, this means, when the winding diameter is 0.5 mm smaller than the bobbin diameter.
- Sewing.
Winder lever 4 ends the procedure as soon as the bobbin is full.



6.6 Inserting the Underthread Bobbin

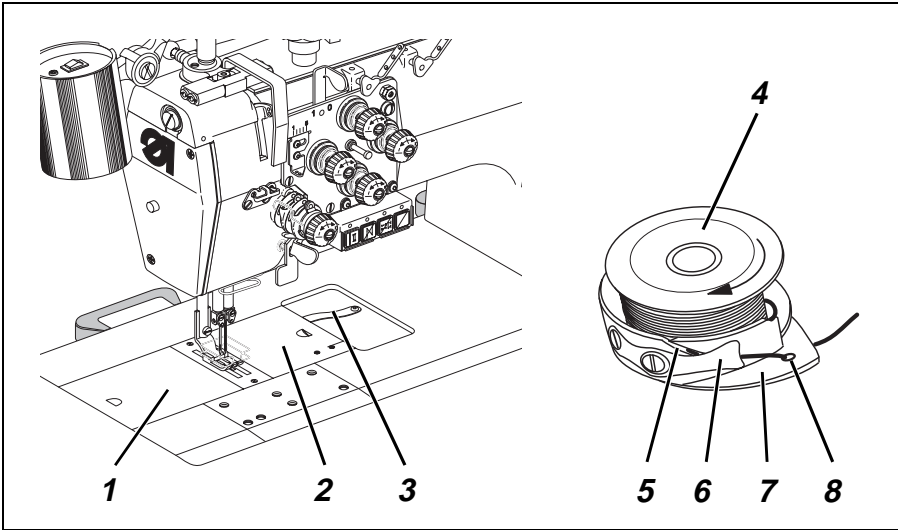

Caution Risk of Injury !

Turn the main switch off.
Change the underthread bobbins only with the sewing machine turned off.

Removing the empty underthread bobbin

- Bring the needle bars into the high position.
- Open the needle plate slides 1 and 2.
Unlock the right needle plate slide 2 by pressing down on the leaf spring 3.
- Lift the bobbin case flap.
- Remove the bobbin case with empty underthread bobbin.

Threading the underthread

- Insert a full bobbin 4 into bobbin case 7:
When the thread is being drawn off, the bobbin must turn in the direction of the arrow.
- Pull the underthread through slit 5 under tension spring 6.
- Thread the underthread through hole 8 in the bobbin case top.
This assures the **thread trimming** function.
- Cut off the underthread up to approx. 3 cm.
- Insert the bobbin case top with full bobbin into the hook.
- Close the bobbin case flap.
- Close the needle plate slides 1 and 2 again.



6.7 Setting the Underthread Tension

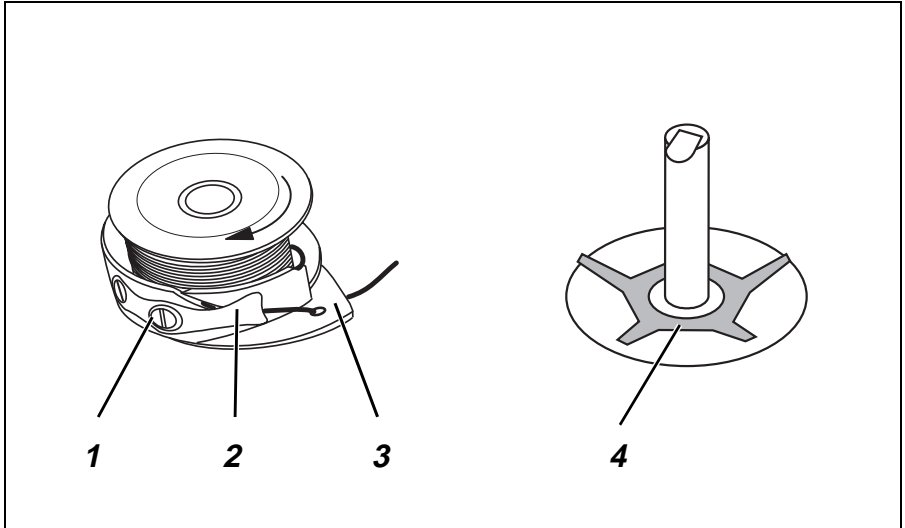

Caution Risk of Injury !

Turn the main switch off.
Set the underthread tension only with the sewing machine turned off.

- Take out the bobbin case with bobbin.
- To lift the bobbin case reach under the nose 3.
- Set tension spring 2 by turning the adjustment screw 1.
- Insert the bobbin case with bobbin into the hook again.

Note:

The spring 4 is to be found under the bobbin in the hook.

When thread trimming the underthread automatically it prevents a "running-on" of the bobbin.



ATTENTION !

The spring 4 must always be in the bobbin case in the position shown in the sketch.

The spring 4 should not be lost during cleaning work.



6.8 Inserting and Changing Needles

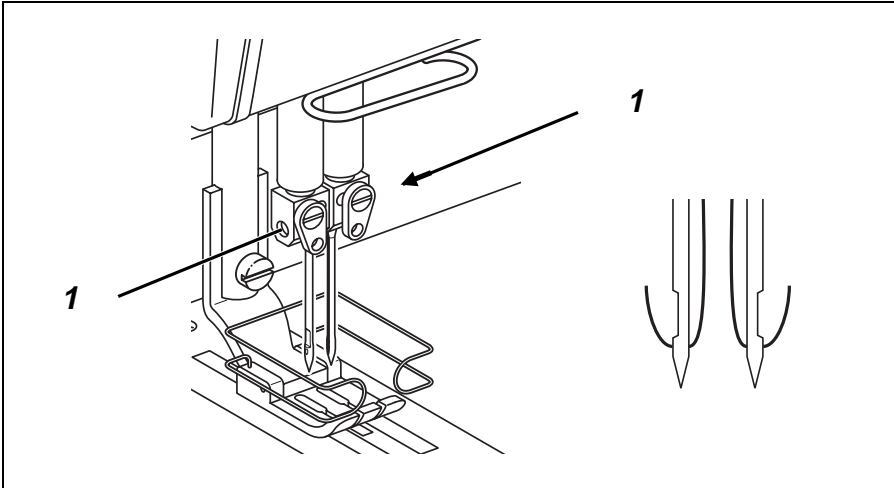

Caution Risk of Injury !

Turn the main switch off.
Change needles only with the sewing machine turned off.

- Bring the needle bars into the high position.
- Loosen screws 1 (right or left, 1.5 Allan key in the accessories pack).
- Remove the needles from the needle holder.
- Insert new needles up to the stop in the holes of the needle holder.



ATTENTION !

Seen from the operator side, the furrow of the left needle must face to the left and the furrow of the right needle to the right.

- Tighten screws 1 (right or left).



ATTENTION !

The factory-set clearance of the hook to the needle is only correct for needles with a thickness of Nm 80 to 100. When inserting a thinner or thicker needle, the clearance must be corrected (see Service Instructions).

Non-observance of the above correction can lead to the following errors:

When inserting thinner needles:

- Missing stitches
- Damage to the thread

When inserting thicker needles:

- Damage to the hook point
- Damage to the needle



6.9 Lifting the Sewing Feet

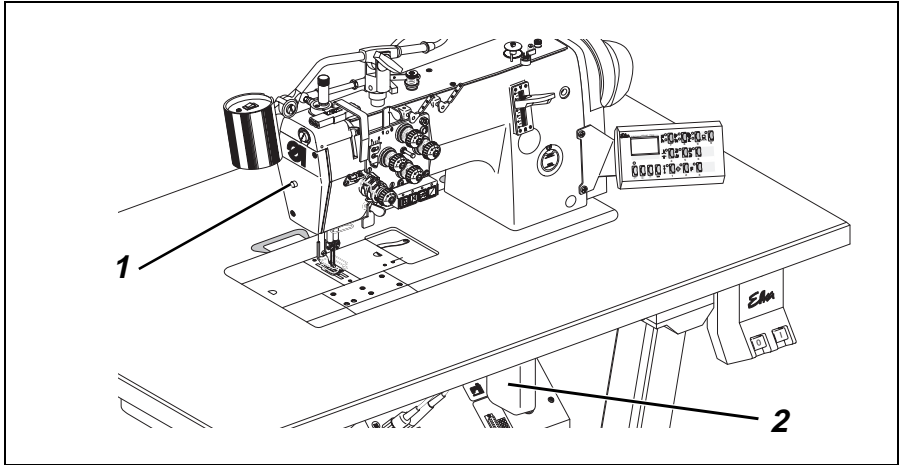

The sewing feet can be raised mechanically or pneumatically. Depending on the equipment of the special sewing machine, the lifting occurs through operation of the knee lever 2 or the stepping back on the pedal.

Mechanical sewing foot lift (knee lever 2)

- To move the material (e.g. for corrections) operate knee lever 2. The sewing feet remain raised as long as the knee lever 2 is operated.

Pneumatic sewing foot lift (pedal)

- Step halfway back on the pedal. The sewing feet rise when the machine stops.
- Step the pedal completely to the back. Activate the thread trimmer and lift the sewing feet.

6.10 Arresting the Sewing Feet in the High Position

The mechanically or pneumatically lifted sewing feet can be arrested in the high position with button 1 (e.g. for winding the underthread).

- With the sewing machine stopped step half back on the pedal or operate the knee lever. The sewing feet rise.
- Press button 1 and release the pedal or knee lever. The raised sewing feet are arrested in the high position.
- Step half back on the pedal or operate the knee lever again. The arresting of the sewing feet is cancelled.



6.11 Setting the Sewing Foot Pressure

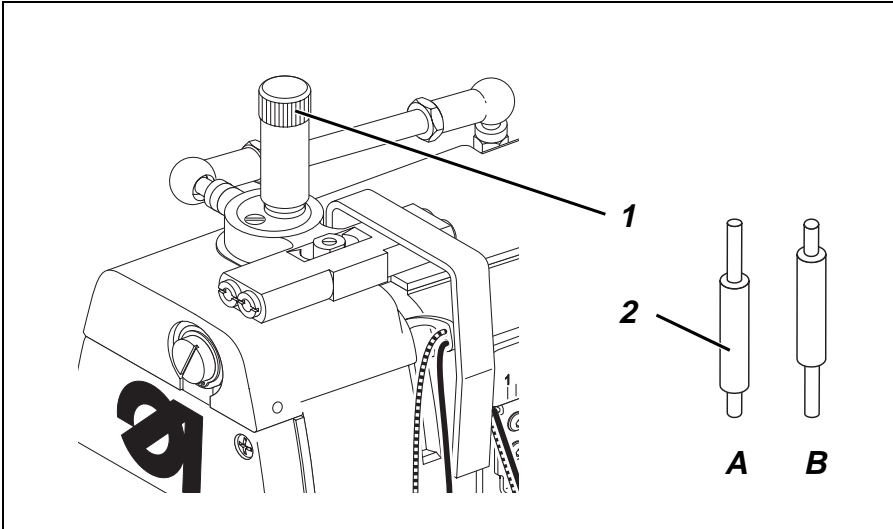

The desired sewing foot pressure is set with sleeve 1.

- Increase sewing foot pressure = Turn sleeve 1 clockwise.
- Decrease sewing foot pressure = Turn sleeve 1 counterclockwise.

The setting range can be changed by turning the bolt 2.

- Screw off sleeve 1.
- Take out bolt 2, turn and insert again.
Fitting position **A** = Higher sewing foot pressure.
Fitting position **B** = Lower sewing foot pressure.
- Replace sleeve 1 again and set the desired sewing foot pressure.



6.12 Stitch Length on Sewing Machines without Automatic Bartacking

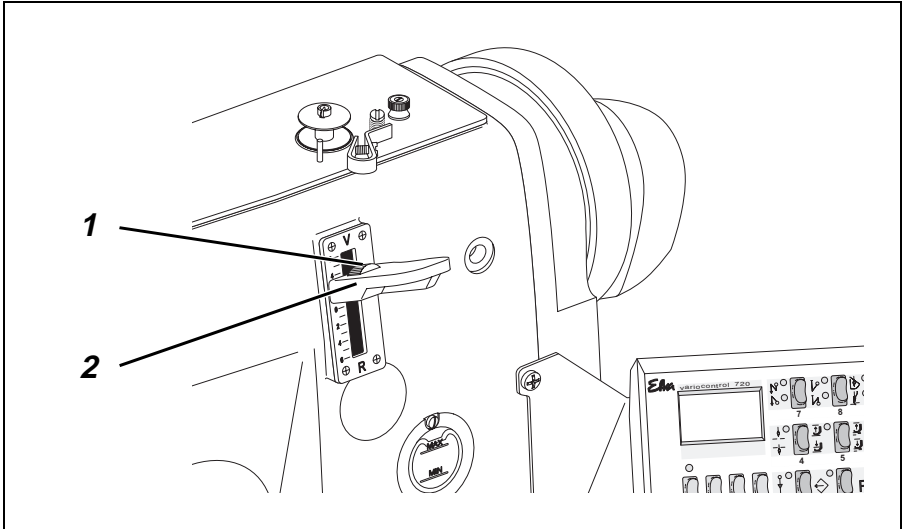

The desired stitch length is set with the knurled nut 1 in the stitch regulator lever. It is the same for forward and reverse sewing.

Changing the stitch length during sewing.

With the stitch regulator lever 2 the stitch length can be continuously changed during sewing between the set forward and reverse stitch length.

- Stitch regulator lever all the way up.
Forward sewing with the set stitch length.
- Stitch regulator lever all the way down.
Reverse sewing with the set stitch length.



6.12.1 Stitch Length on Sewing Machines with Automatic Bartacking

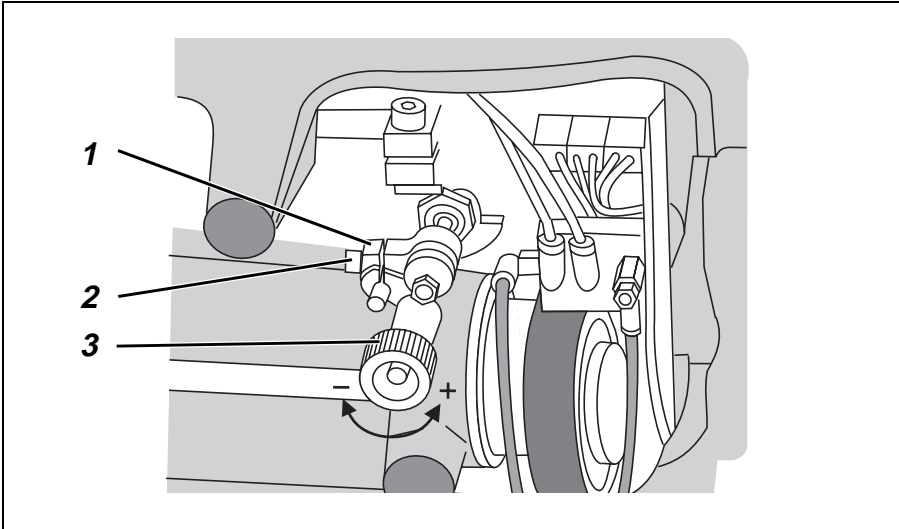

Sewing machines with automatic bartacking

(Subclass 381-160162 and 382-160162)

On sewing machines with automatic bartacking the stitch lengths are set with the knurled nut 3 and the block 1.

The knurled nut in the stitch regulator lever (see pos. 1 page 19) is turned completely back.



Caution Risk of Injury !

Turn the main switch off.

Set the stitch length only with the sewing machine turned off.

- Tilt the sewing machine head back.
- Turn the knurled nut in the stitch regulator (see pos. 1 page 19) completely back.
- Set the stitch length for **reverse sewing**.
Loosen screw 2.
Decrease stitch length = Push block 1 up.
Increase stitch length = Push block 1 down.
Tighten screw 2 again.

ATTENTION ! With the moving of block 1, the stitch length for forward sewing changes.

- Set the stitch length for **forward sewing**.
Decrease stitch length = Turn knurled nut 3 clockwise.
Increase stitch length = Turn knurled nut 3 counterclockwise.
- Right the sewing machine head again.



6.13 Turning the Needle Bars On and Off

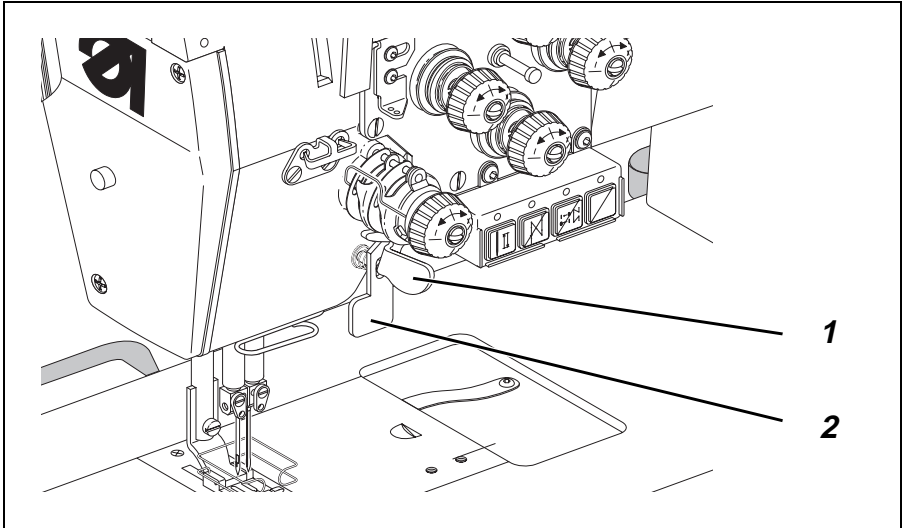

The needle bars can be turned off with lever 1.

The position of lever 1 determines which needles are working:

- Lever 1 in the left position.
Left needle bar turned off (right needle bar is working).
- Lever 1 in the right position.
Right needle bar turned off (left needle bar is working).
- Lever 1 in the middle position.
Both needle bars are working.

The needle bar is arrested in its high position. The lever 1 must therefore be operated in standstill (down) or during the upward movement, before the needle bar lies 3 mm in front of its high position.

If switching occurred too late, then the handwheel must be turned back a suitable distance. During the subsequent forward turn the needle bar is then arrested in the high position.

Turning the switched-off needle bar on again:

- Press switch 2.
The lever 1 moves into the middle position by itself.
The switched-off needle bar is turned on again. It follows the working needle bar when this has reached its high position.

The switch must be operated in needle low position or during the upward movement so that the switched-off needle bar can follow the working needle bar by the next stitch.

If switching occurred too late, then the handwheel must be turned back a suitable distance. During the subsequent forward turn the needle bar is coupled in.



6.14 Roller Top Feed

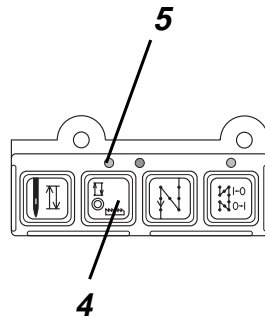
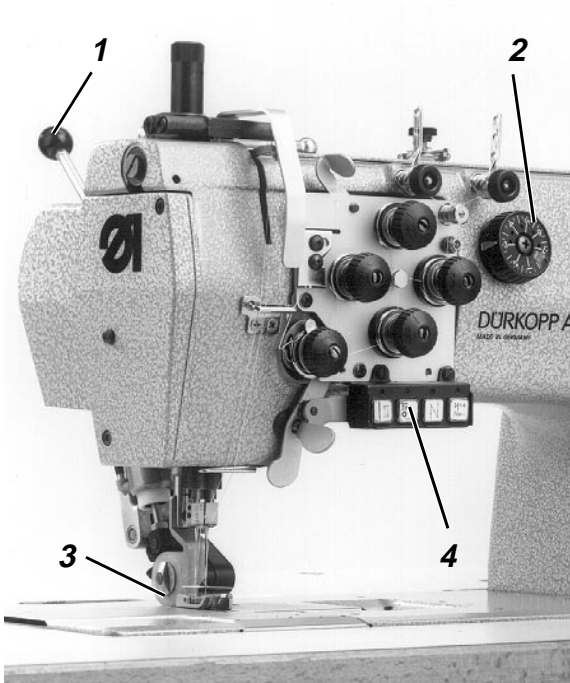

The feed distance of the roller top feed is a max. 7 mm.

It can be set differently than the bottom feed with the setting dial 2.

The feed roller 3 is automatically lowered after 10 stitches. The number of stitches prior to the automatic lowering of the feed roller can be set with parameter F-186 (technician level).

The feed roller 3 is automatically raised during lifting of the sewing foot and at seam bartacking.

- Hand lever 1 up:
The feed roller with drive is completely swung out of the work area. The roller top feed (puller) has no function.
Hand lever 1 down:
The puller is swung into the work area.
- Operate switch 4:
The feed roller is raised or lowered.
LED 5 ON = Feed roller raised.
LED 5 OFF = Feed roller lowered.
- Set the setting dial 2.
The feed distance of the roller top feed can be set independent of the bottom feed.



7. Controls and Control Panel



ATTENTION !

These Operating Instructions list only those functions of the keys and the changes of the parameters to be conducted by the operator.

Please find the comprehensive description of the controls in the enclosed current Operating Instructions of the motor manufacturer.

7.1 General

The controls are programmed and the functions for the seams are set via the control panel.

Appropriate to the sewing task, sewing can occur manually or with seam programming.

For different sewing tasks the seam procedures can be programmed and their functions (beginning bartack, end bartack, stitch counting, thread trimming, etc.) and parameter values (number of stitches, seam length, speed, etc.) individually assigned.

The entry occurs in the programming mode.

The parameters and their assigned values are shown in the display.

The programmed seams remain in memory even after the sewing machine is turned off.

In order to avoid an unintentional changing of preset functions, operations are divided among different levels (operator, technician, equipper).

The operator (seamstress) can program directly.

The access to the other levels is only possible after the entry of a code number or different keys must be pressed simultaneously.

RESET

If the controls have been totally misadjusted, then the technician can return all setting values to the delivery status (works setting) with this function.

The function is described in the Service Instructions for the 381 - 382 !



7.2 Keys on the Control Panel

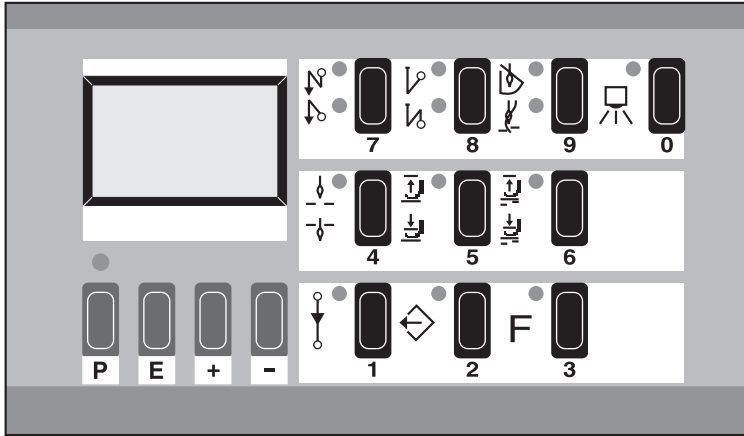

Key	Function	Settings
P	Accessing or exiting the programming mode	
E	Confirming a change in a parameter value	
+	Increasing the shown parameter value	
-	Decreasing the shown parameter value	
1	Stitch counting	ON / OFF
2	Programming / Working through the seam runs	
3	Function key (programmable)	
4	Base position of the needle	UP / DOWN
5	Automat. foot lifting during stop in the seam	ON / OFF
6	Automat. foot lifting after thread trimming	ON / OFF
7	Beginning bartack	SINGLE / DOUBLE / OFF
8	End bartack	SINGLE / DOUBLE / OFF
9	Thread trimmer Thread wiper	ON / OFF ON / OFF
0	Light barrier function *	ON / OFF

* = Key function is not assigned in this machine class.



7.3 Changing Parameter Values

The changing of parameter values at the operator level occurs via the four green keys ("P", "E", "+", "-") under the display. In the parameter list on the next page are listed all parameters which can be changed at the operator level.

1. Accessing the programming mode

- Press the "P" key.
The LED above the key blinks.
It shows that the controls are in the programming mode.

2. Displaying the first parameter of the operator level

- Press the "E" key.
The first parameter with the corresponding parameter value appears in the display.
Example: "Arv 003" Arv = Short designation of the parameter
 003 = Set parameter value

3. Changing the parameter value shown

- Increase or decrease the parameter value with the "+" and "-" keys.
If the "+" or "-" key remains pressed the parameter value continues changing until the key is released.

4. Storing the changed parameter value

- Press the "E" key.
The changed parameter value is stored.
- The next parameter of the operator level appears in the display.
Through repeated pressing of the "E" key, all parameters of the operator level are called up sequentially.

5. Exiting the programming mode

- Press the "P" key.
The parameter value changed last is stored.
- The controls exit the programming mode.



7.4 "Operator Level" Parameter List:

Parameter	Function	Setting		
		Max.	Min.	Ex works
000 Arv	Beginning bartack stitches-forward	254	0	2
001 Arr	Beginning bartack stitches-reverse	254	0	4
002 Err	End bartack stitches-reverse	254	0	3
003 Erv	End bartack stitches-forward	254	0	3
004 LS	Light barrier compensation stitches *	254	0	4
005 LSF	Number of stitches of the light barrier filter for knit goods *	254	0	0
006 LSn	Number of light barrier seams *	15	1	1
007 Stc	Number of stitches of a seam with stitch counting *	254	0	10
008 F	Assignment to key 3 of a parameter from the technician level 1 = Soft start ON / OFF 2 = Fancy stitch bartack ON / OFF 3 = Stroke adjustment locking = ON Stroke adjustment tentative = OFF 4 = Needle cooling ON / OFF 5 = Turning back ON / OFF	5	1	2
009 LSI	Sensitivity setting of the continuous beam light barrier *	255	0	16
010 cLS	PEC compensation stitches with stitch shortening *	254	0	8
080 Sav	Number of stitches-beginning fancy bartack forward	254	0	3
081 SAR	Number of stitches-beginning fancy bartack reverse	254	0	3
082 Ser	Number of stitches-end fancy bartack reverse	254	0	3
083 Sev	Number of stitches-end fancy bartack forward	254	0	3
085 cFW	Number of stitches of the remaining thread monitor count *	2540	0	0

* = Key function is not assigned in this machine class.



ATTENTION !

Several parameters at the technician level must be appropriately set for classes **381** and **382**.
See Installation Instructions Chapter 6.10.



7.5 Key Bank on the Machine Arm

The assignment of the keys of the key bank on the machine arm is dependent on the class.

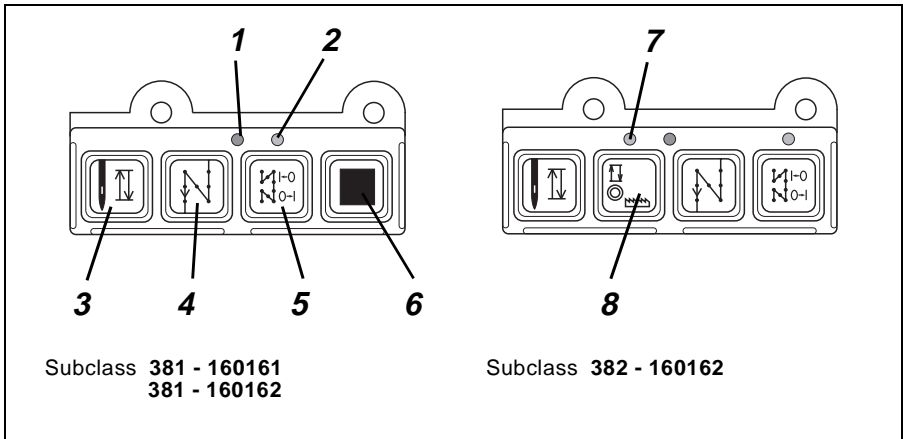

LED Key	Function
1	Display: " Sewing Drive Turned On "  Caution Risk of Injury ! With the sewing drive turned on (LED 1 is lit) the following work may not be conducted: <ul style="list-style-type: none"> - Threading the needle and underthreads. - Changing a bobbin, changing a needle. - Setting the tension regulator. - All activities in the motion area of elements.
2	LED display: The next beginning or end bartack will, depending on the setting of the control panel, be either called up or suppressed
3	Positioning the needle in the high position or low position. The function of key 3 can be determined with parameter F-144 . 1 = Needle high, 2 = Needle high / low, 3 = Single stitch The factory setting is 1 = Needle high.
4	Manual reverse sewing. The machine sews in reverse as long as key 4 is pressed.
5	Calling up or suppressing the beginning or end bartack. If beginning or end bartacking is generally turned on, then an operation of the switch will suppress the next bartack. If beginning or end bartacking is generally turned off, then an operation of the switch will call up the next bartack.
6	Key without function.
7	LED display: Top feed roller raised.
8	Raising or lowering the top feed roller.



8. Sewing

The description of sewing assumes the following preconditions:

- The following functions are set at the control panel:
 - Beginning bartack: ON End bartack: ON
 - Sewing foot position before and after trimming: LOW
 - Needle position before trimming: LOW (position 1)
- Main switch turned on.
- The last sewing procedure was completed with end bartack and thread trimming.

Operation and function sequence during sewing:

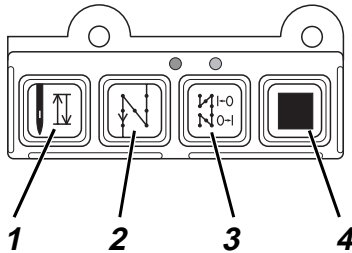

Sewing procedure	Operation / Remarks
<p>Before the sewing start</p> <p>Initial position</p> <p>Position the material at the seam beginning</p>	<ul style="list-style-type: none"> - Pedal in rest position. Sewing machine is idle. Needle up. Sewing feet down. - Step back on the pedal. The sewing feet rise. - Position the material. - Release the pedal. The sewing feet lower onto the material.
<p>At the seam beginning</p> <p>Beginning bartack and continue sewing</p> <p>Beginning bartack is not to be sewn</p>	<ul style="list-style-type: none"> - Step forward on the pedal and hold down. The beginning bartack is sewn. Subsequently the machine continues sewing at the speed determined with the pedal. - Press key 3 (bartack suppression). - Step forward on the pedal. - The machine sews at the speed determined with the pedal.



Sewing procedure	Operation / Remarks
<p>In the seam middle</p> <p>Interrupting the sewing procedure</p> <p>Continuing the sewing procedure (after release of the pedal)</p> <p>Sewing a corner</p> <p>Sewing an intermediate bartack</p>	<ul style="list-style-type: none">- Release the pedal (rest position) . The machine stops in the first position (needle down). The sewing feet are down.- Step forward on the pedal. The machine sews at the speed determined with the pedal. The beginning bartack is not sewn.- Release the pedal. The machine stops in the first position (needle down). The sewing feet are down.- Turn the needle bar right or left off.- Conduct the required stitches with the second needle bar.- Step half back on the pedal- Turn the material around the needle. Only one needle may be in the material.- The sewing feet lower. Sew the necessary stitches.- Turn the needle bar on again.- Press key 2 and hold the pedal down. The machine sews in reverse as long as key 2 is pressed. The speed is determined by the pedal.
<p>At the seam end</p> <p>Removing the material</p> <p>End bartack is not to be sewn</p>	<ul style="list-style-type: none">- Step the pedal completely back and hold down. The end bartack is sewn. The thread is trimmed. The machine stops in the second position. The sewing feet are raised.- Press key 3 (bartack suppression). Step the pedal completely back. The end bartack is not sewn. The thread is trimmed. The machine stops in the second position. <p>The position of the sewing feet is dependent on press key 6 on the control panel:</p> <ul style="list-style-type: none">a) ON:<ul style="list-style-type: none">- Sewing feet raised.b) OFF:<ul style="list-style-type: none">- Sewing feet down.



9. Maintenance



Caution Risk of Injury !

Turn the main switch off!
The maintenance of the sewing machine may only occur when it is turned off.

The maintenance work must occur at the latest as per the maintenance intervals listed in the tables (see column "Operating Hours").

When working very linty materials, shorter maintenance intervals may result.

9.1 Cleaning and Inspection

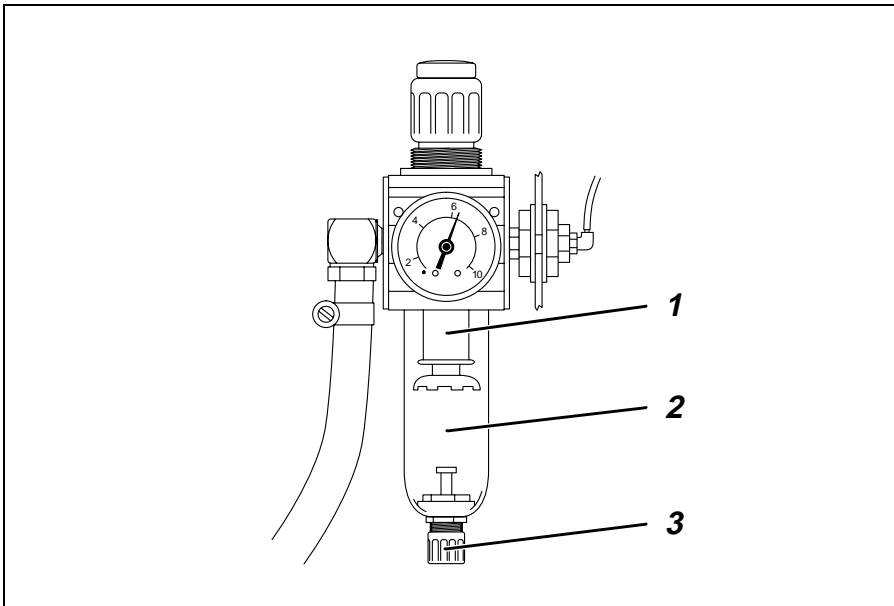

A clean sewing machine protects against malfunctions!

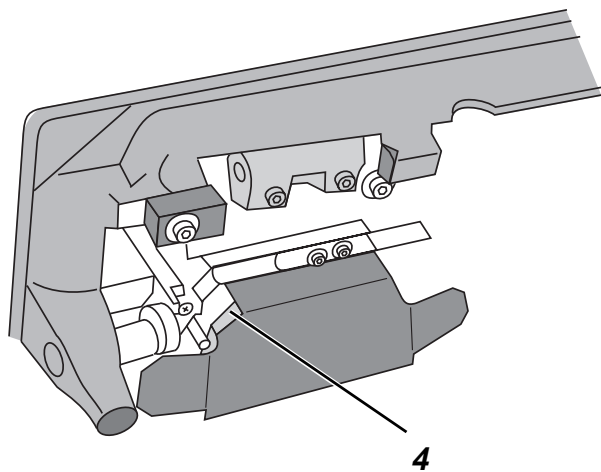
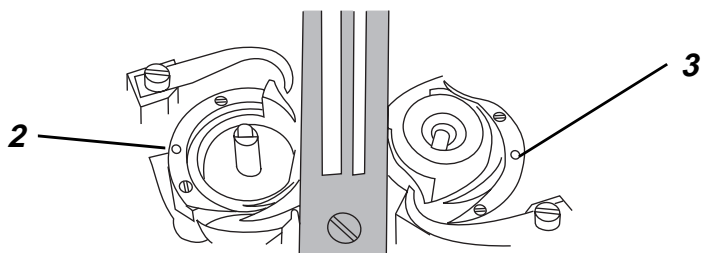
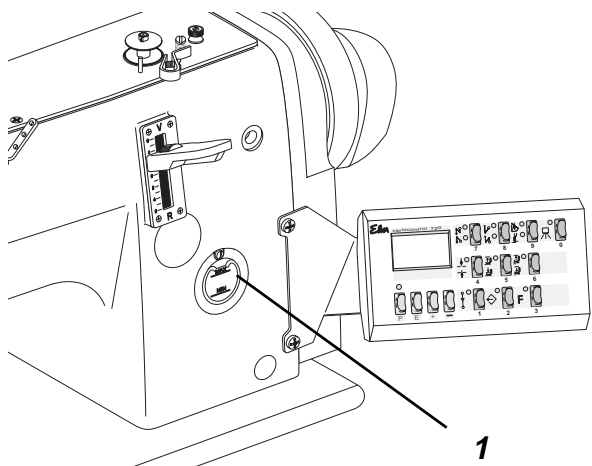





9.2 Oil Lubrication

	<p>Caution Risk of Injury ! Oil can cause skin rashes. Avoid longer skin contact. After contact wash yourself thoroughly.</p>
	<p>ATTENTION ! The handling and disposal of mineral oils is subject to legal constraints. Deliver used oil to an authorized reception point. Protect your environment. Take care not to spill any oil.</p>

For lubrication of the special sewing machine use only **ESSO SP-NK 10** lubricating oil or an equivalent oil with following specification:

- Viscosity at 40° C : 10 mm/s
- Flash point: 150 °C

ESSO SP-NK 10 is available from **DÜRKOPP-ADLER AG** sales offices under the following parts no.s:

- 2 liter container: 9047 000013
- 5 liter container: 9047 000014

Lubrication of the machine head

- Check the reservoir 1 **weekly**.
The oil level should not drop below the "**MIN**" marker line.
If necessary, fill oil through the hole in the viewing glass up to the "**MAX**" marker line.

Lubrication of the hook

- The hook run must be lubricated **often daily**.
Supply lubricating points 2 + 3 often during the day with a few drops of oil.
- The felt 4 under the hook drives is to be checked **weekly**.
If necessary, supply the felt 4 with oil at the open right and left corners.



10. Optional Equipment

10.1 Thread Wiper

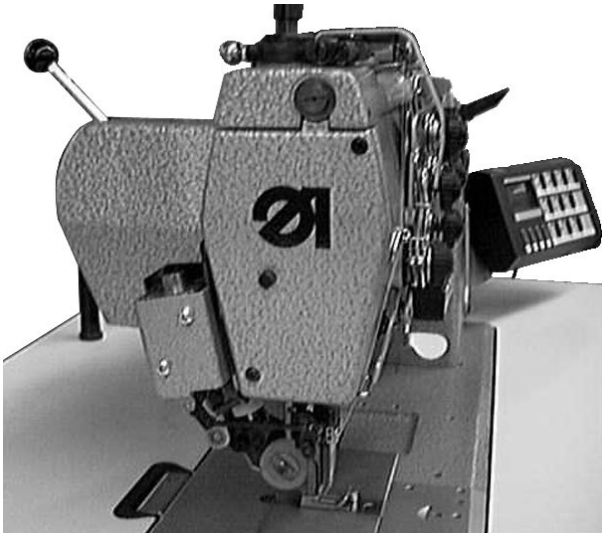

If, at the beginning of a seam, the needle thread end is to be drawn through on the underside of the material, then it should not get clamped in between the sewing foot and the material. The thread wiper assures that the needle thread end hangs out of the needle eye loosely.

The movement of the thread wiper occurs after the trimming of the thread before the feet are lifted.

Note

The thread wiper can be turned on and off at the control panel.