



281

Upgrade manual

Thread tension lift

All rights reserved.

Property of Dürkopp Adler GmbH and protected by copyright. Any reuse of these contents, including extracts, is prohibited without the prior written approval of Dürkopp Adler GmbH.

Copyright © Dürkopp Adler GmbH - 2021

1	Parts set components	3
2	Changing PCB	4
2.1	Removing old PCB	4
2.2	Installing new PCB	6
3	Setting the parameters.....	8
4	Appendix	9

1 Parts set components

Check whether the scope of delivery for parts set 0281 590154 is correct prior to exchanging the PCB.

Material number	Quantity	Description
9850 281005	1	PCB
9870 281006	1	Cable
0791 281705 EN	1	Upgrade manual

2 Changing PCB

DANGER



Danger of life-threatening electric shock

The PCB should only be changed by qualified technicians.

Switch off the machine and disconnect the power plug before changing the PCB.

Make sure the power plug cannot be accidentally plugged back in.

WARNING



Risk of crushing due to the weight of the machine

Always tilt the machine in a controlled manner.

Never reach in to areas where there is a risk of crushing.

2.1 Removing old PCB

1. Unscrew 3 screws (4) of the handwheel (1) and remove the handwheel (1).

Figure. 1: Removing the handwheel and machine arm cover

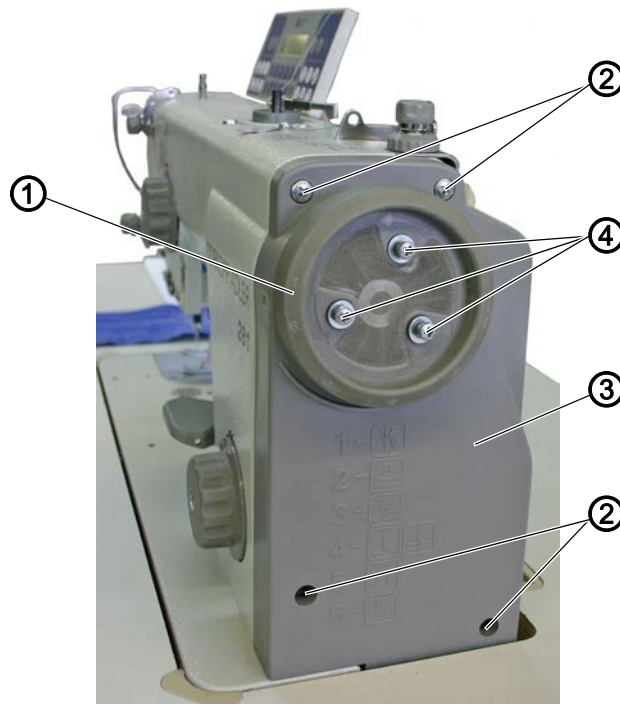

(1) - Handwheel
(2) - Cover screws

(3) - Cover
(4) - Handwheel screws

2. Unscrew 4 screws (2) on the cover (3) of the machine arm.
3. Tip the machine back slightly and remove the cover (3).
4. In the low-voltage range (6), disconnect all plugs carefully.

Figure. 2: Disconnecting plug connections

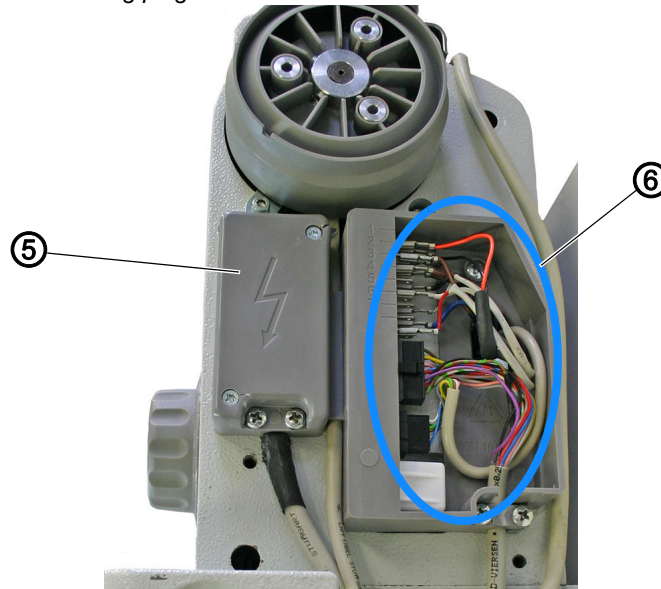

(5) - High-voltage range cover (6) - Low-voltage range

5. In the high-voltage range, screw off the cover (5).
6. Loosen 6 screws (8) of the luster terminals, the equipotential bonding (9) does not have to be unscrewed.

Figure. 3: Removing the electrode holder

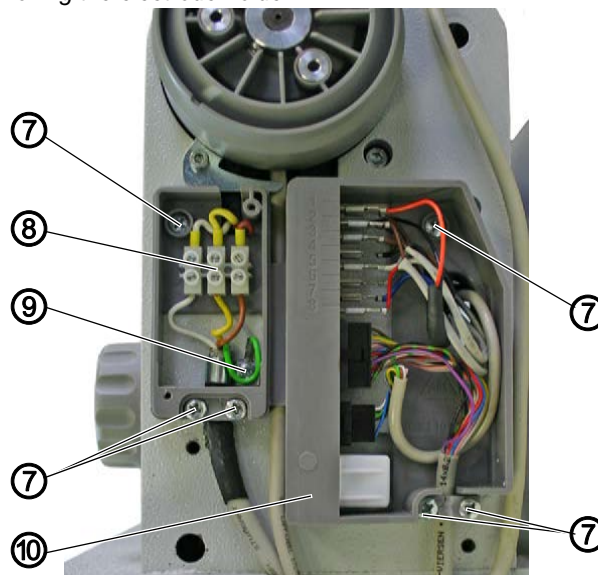

(7) - Screws (6x) (9) - Equipotential bonding
 (8) - Luster terminal screw (10) - Electrode holder

7. Unscrew 6 screws (7) and remove the electrode holder (10) from the machine.
8. Remove the PCB from the electrode holder (10).
- ↳ The old PCB is removed.

2.2 Installing new PCB

ATTENTION

Material damage due to forceful installation

Do not push the PCB into the electrode holder using force. Ensure that the alignment is correct when installing the new PCB.

ATTENTION

Material damage due to crushing possible

Route the cables so that they have no contact with the rotating shaft. Do not crush the cables when laying.

1. Push the new PCB (1) in the electrode holder (2) with the correct alignment.

Figure 4: Positioning the new PCB in the electrode holder

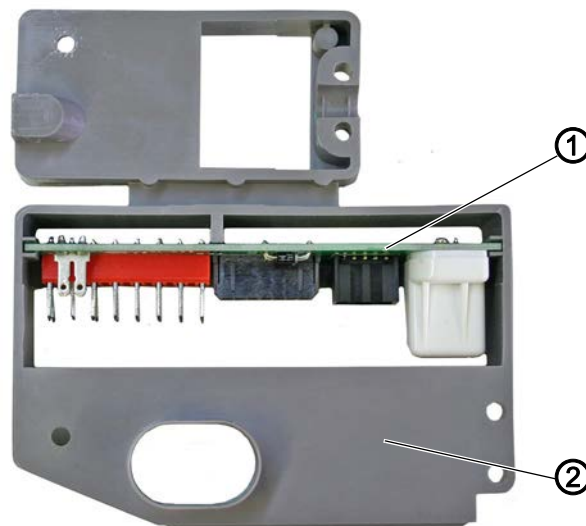

(1) - PCB

(2) - Electrode holder

2. Screw on the electrode holder (2) again.
3. Connect the plug in the low-voltage range in accordance with the circuit diagram, [4 Appendix](#), page 9.
4. Connect the luster terminals in the high-voltage range according to identical colors.

Figure 5: Connecting the luster terminals

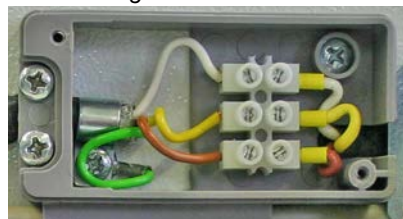

5. Mount the high-voltage range cover again.
- ↪ The new PCB is installed.

6. Fix the cover (3) of the machine arm in place with the 4 screws (4).

Figure. 6: Fixing the cover of the machine arm in place

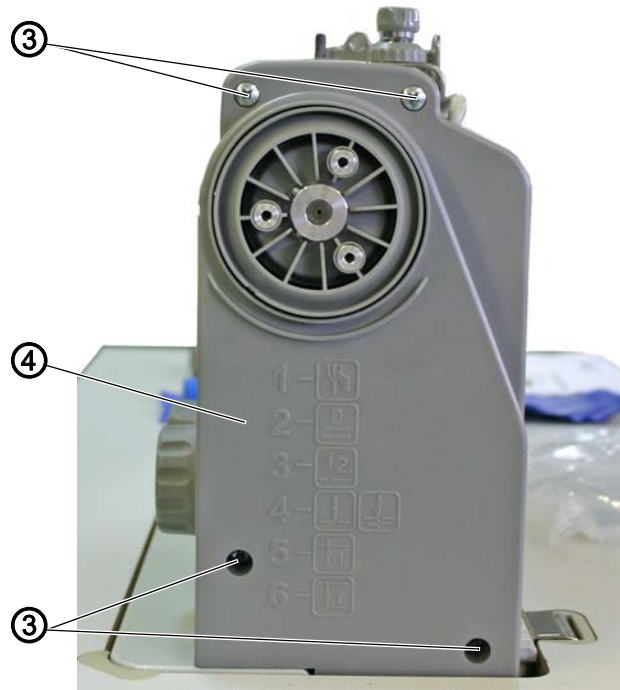

(3) - Screw (4x)

(4) - Cover

7. Screw on the handwheel (6) again, evenly and crosswise

Attention: Note the marking (5) for the correct alignment!

Figure. 7: Screwing on the handwheel

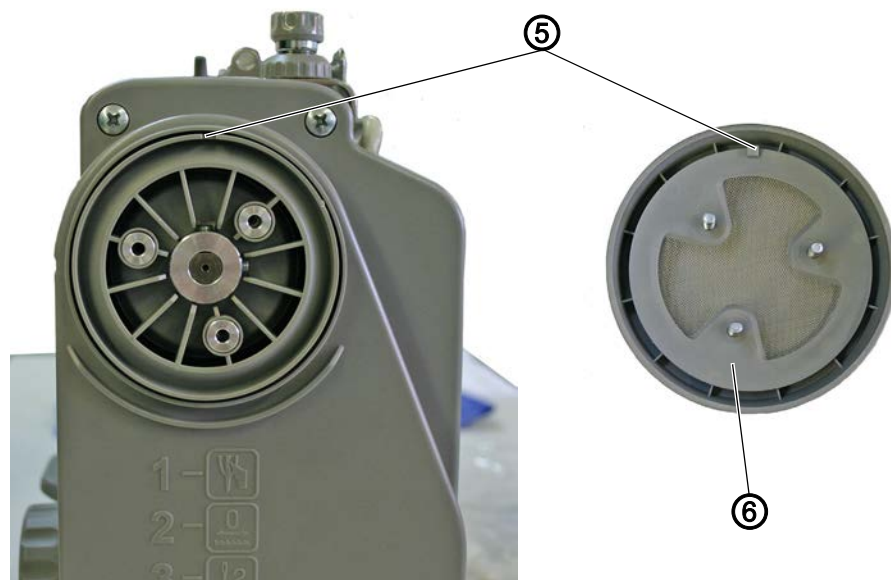

(5) - Marking

(6) - Handwheel

3 Setting the parameters

The thread tension lift can be used in a variety of different operating modes.

For this, the following values must be set on technician level, see also  *Parameter Sheet 281*:

Parameters	Preset value	Unit	Description
t 09 00	0	-	Mode of thread tension and thread tension reduction when sewing foot lifter is active 0 = No thread tension lift 1 = Thread tension lift in the seam 2 = Thread tension lift after thread cutting 3 = Thread tension lift in the seam and after thread cutting

4 Appendix



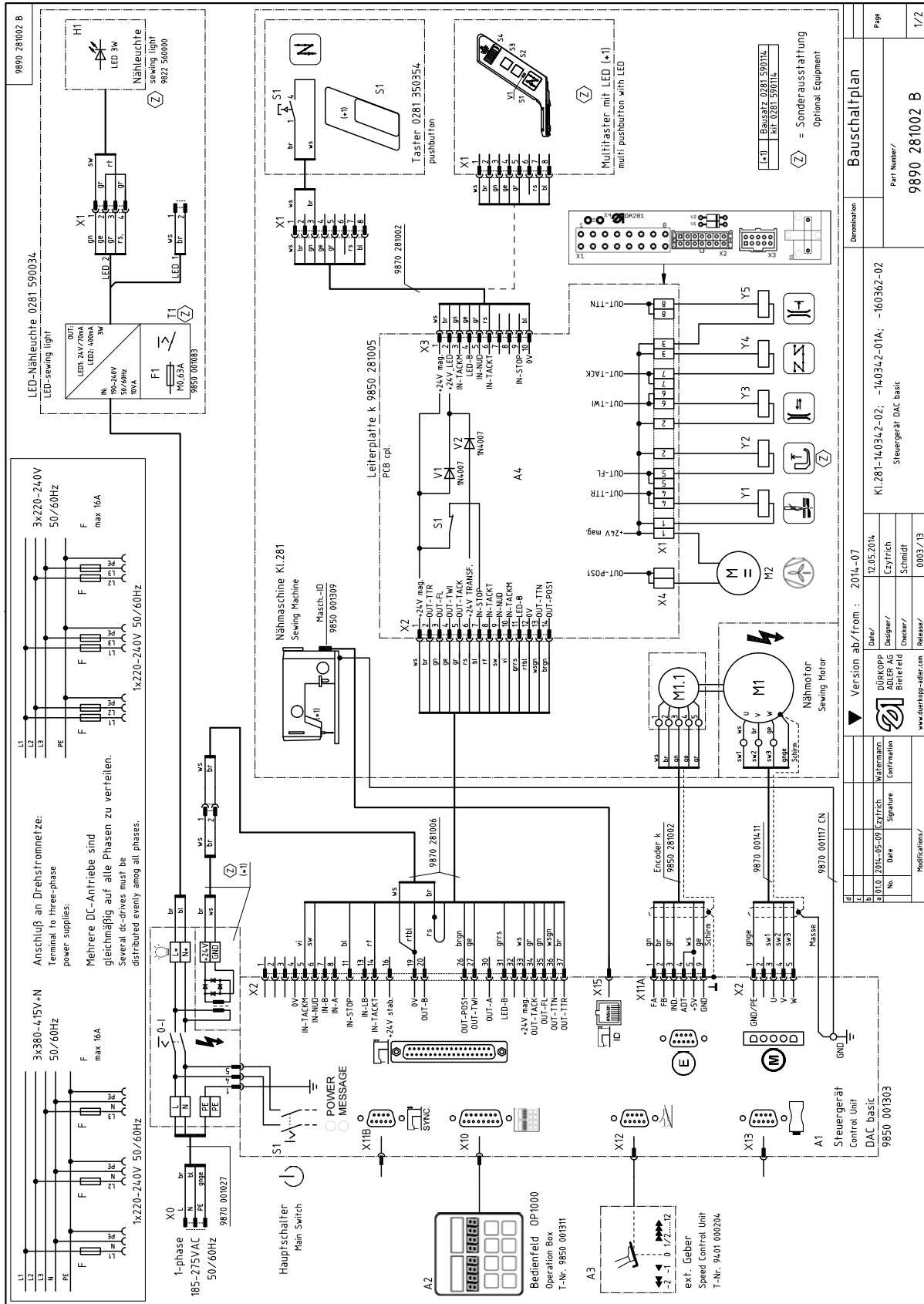



Figure 8: Circuit diagram 281

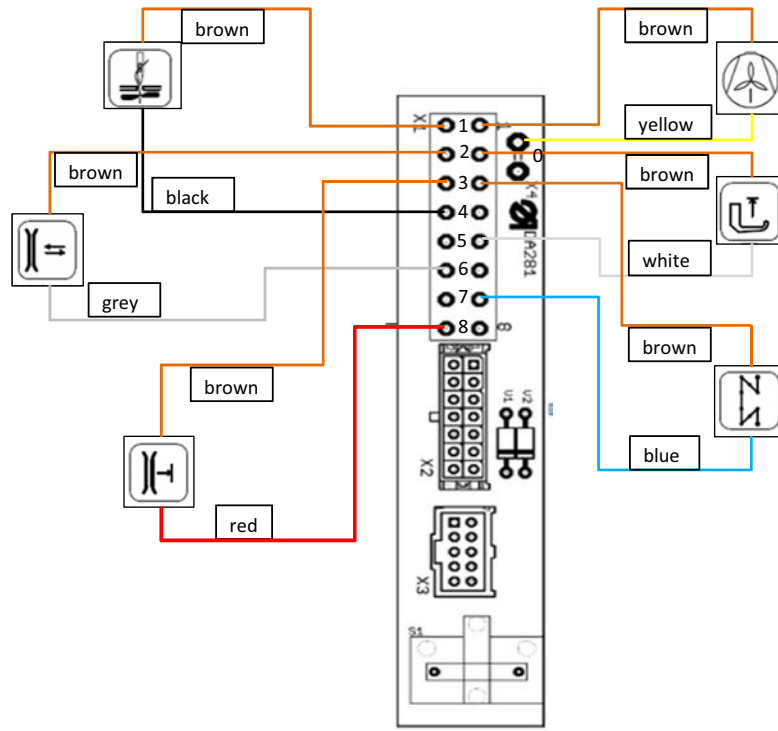

Denomination		Bauschaltplan	
Version ab/ from :	2014-07	Part Number/	9890 281002 B
Date/	12.05.2014	Page	1/2
Designer/	DÜRKOPP ADLER AG	Denomination	Kl.281-14.034.2-02; -14.034.2-01A; -16.0362-02
Signature	Briefeld	Steuergerät DAC basic	
Release/	Schmidl		
Modification/	0003/13		
Watermann Confirmation			
Czyfrich			
www.duerkopp-adler.com			

Figure. 9: Circuit diagram 281 in detail



- | | | | |
|---|------------------------|---|------------|
|  | Thread cutter |  | Bartacking |
|  | Thread tension release |  | Foot lift |
|  | Thread clamp |  | Fan |



DÜRKOPP ADLER GmbH
Potsdamer Str. 190
33719 Bielefeld
Germany
Phone +49 (0) 521 925 00
E-Mail: service@duerkopp-adler.com
www.duerkopp-adler.com