

**CNC automat for bartacking seams  
and short seams**

Operating Instructions

Installation Instructions

Service Instructions

1

2

3

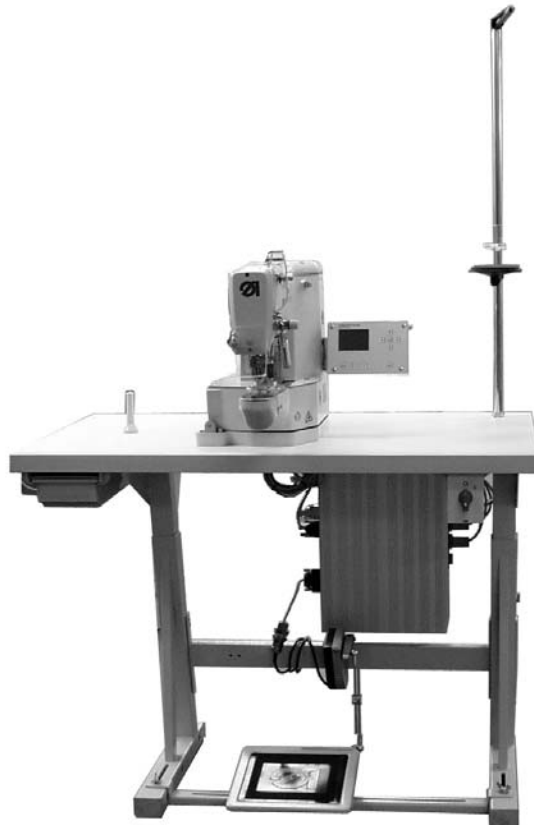

## **Summary**

Operating Instructions  
Installation Instructions  
Service Instructions

Interconnection-diagram

9890 510001 B

# Foreword

This instruction manual is intended to help the user to become familiar with the machine and take advantage of its application possibilities in accordance with the recommendations.

The instruction manual contains important information on how to operate the machine securely, properly and economically. Observation of the instructions eliminates danger, reduces costs for repair and down-times, and increases the reliability and life of the machine.

The instruction manual is intended to complement existing national accident prevention and environment protection regulations.

The instruction manual must always be available at the machine/sewing unit.

The instruction manual must be read and applied by any person that is authorized to work on the machine/sewing unit. This means:

- Operation, including equipping, troubleshooting during the work cycle, removing of fabric waste,
- Service (maintenance, inspection, repair and/or
- Transport.

The user also has to assure that only authorized personnel work on the machine.

The user is obliged to check the machine at least once per shift for apparent damages and to immediately report any changes (including the performance in service), which impair the safety.

The user company must ensure that the machine is only operated in perfect working order.

Never remove or disable any safety devices.

If safety devices need to be removed for equipping, repairing or maintaining, the safety devices must be remounted directly after completion of the maintenance and repair work.

Unauthorized modification of the machine rules out liability of the manufacturer for damage resulting from this.

Observe all safety and danger recommendations on the machine/unit! The yellow-and-black striped surfaces designate permanent danger areas, eg danger of squashing, cutting, shearing or collision.

Besides the recommendations in this instruction manual also observe the general safety and accident prevention regulations!

## General safety instructions

**The non-observance of the following safety instructions can cause bodily injuries or damages to the machine.**

1. The machine must only be commissioned in full knowledge of the instruction book and operated by persons with appropriate training.
2. Before putting into service also read the safety rules and instructions of the motor supplier.
3. The machine must be used only for the purpose intended. Use of the machine without the safety devices is not permitted. Observe all the relevant safety regulations.
4. When gauge parts are exchanged (e.g. needle, presser foot, needle plate, feed dog and bobbin) when threading, when the workplace is left, and during service work, the machine must be disconnected from the mains by switching off the master switch or disconnecting the mains plug.
5. Daily servicing work must be carried out only by appropriately trained persons.
6. Repairs, conversion and special maintenance work must only be carried out by technicians or persons with appropriate training.
7. For service or repair work on pneumatic systems, disconnect the machine from the compressed air supply system (max. 7-10 bar). Before disconnecting, reduce the pressure of the maintenance unit.  
Exceptions to this are only adjustments and functions checks made by appropriately trained technicians.
8. Work on the electrical equipment must be carried out only by electricians or appropriately trained persons.
9. Work on parts and systems under electric current is not permitted, except as specified in regulations DIN VDE 0105.
10. Conversion or changes to the machine must be authorized by us and made only in adherence to all safety regulations.
11. For repairs, only replacement parts approved by us must be used.
12. Commissioning of the sewing head is prohibited until such time as the entire sewing unit is found to comply with EC directives.



It is absolutely necessary to respect  
the safety instructions marked by these signs.  
**Danger of bodily injuries !**  
Please note also the general safety instructions.



**Part 3: Service Instructions Class 510**

<b>1.</b>	<b>General notes</b> . . . . .	3
<b>2.</b>	<b>Arm shaft</b>	
2.1	Preparatory work . . . . .	4
2.2	Assembly of the crank . . . . .	5
2.3	Arm shaft position . . . . .	6
2.4	Bevel gear for the handwheel . . . . .	8
2.5	Adjust bobbin winder. . . . .	9
2.6	Thread trimmer cam . . . . .	10
2.7	Crankshaft drive to the hook shaft. . . . .	11
2.8	Sewing motor coupling . . . . .	12
2.9	Reference position of the sewing motor . . . . .	13
2.9.1	Position of the initiator. . . . .	13
2.9.2	Adjust reference position . . . . .	14
<b>3.</b>	<b>Hook, looping stroke and needle bar height</b>	
3.1	Driver shaft . . . . .	17
3.2	Gear segment on the camshaft . . . . .	18
3.3	Gear segment to the driver shaft. . . . .	19
3.4	Needle bar height. . . . .	20
3.5	Distance between hook tip and needle . . . . .	21
3.6	Looping stroke and needle protection. . . . .	22
<b>4.</b>	<b>Thread-guiding parts</b>	
4.1	Thread controller spring . . . . .	23
4.2	Thread regulator . . . . .	25
4.3	Change thread wiper. . . . .	26
4.3.1	General notes . . . . .	26
4.3.2	Remove/mount thread wiper . . . . .	27
4.3.3	Thread wiper height . . . . .	27
<b>5.</b>	<b>Thread trimmer</b>	
5.1	Thread trimmer magnet . . . . .	28
5.2	Position of the hook knife . . . . .	29
5.3	Cutting pressure / Position of the stationary knife . . . . .	30
5.4	Thread guiding sheet . . . . .	32
5.5	Thread trimmer . . . . .	33

<b>6.</b>	<b>Material feed</b>	
6.1	Gauge for reference position . . . . .	34
6.2	Reference position . . . . .	35
6.3	Position of the fabric clamps and the rest plate to the needle . . . . .	37
6.4	Fabric clamp lifting . . . . .	38
<b>7.</b>	<b>Oil lubrication</b>	
7.1	Oil circulation . . . . .	40
7.2	Lubricating oil pump . . . . .	41
<b>8.</b>	<b>Exchange the control unit</b> . . . . .	42
<b>9.</b>	<b>Maintenance</b> . . . . .	42

## 1. General notes

The service instructions on hand describe the adjustment of the automatic bartacker 510.



### **ATTENTION !**

The operations described in the service instructions may only be carried out by qualified staff or other appropriately trained persons!



### **Caution: Danger of injury !**

In case of repair, alteration and maintenance work switch off main switch.

Carry out adjusting operations and functional tests of the running machine only under observation of all safety measures and with utmost caution.

These service instructions describe the adjustment of the automatic bartacker in a logical order. Please observe in this connection that various setting positions are interdependent. The adjustment process must therefore be carried out in the order given.

For all setting operations of parts involved in the stitch formation a new needle without any damage has to be inserted.

## 2. Arm shaft

### 2.1 Preparatory work

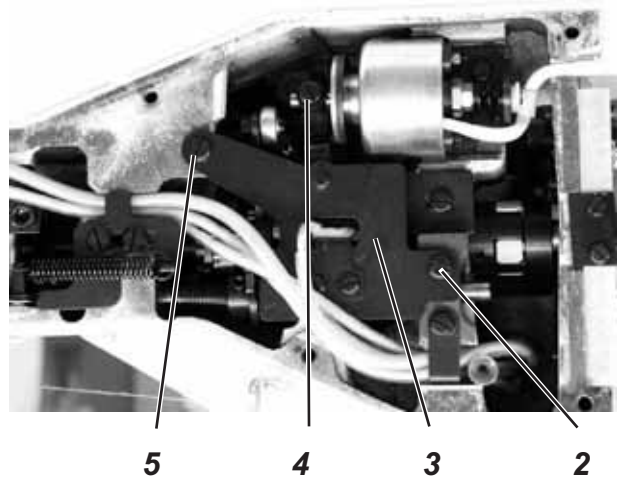
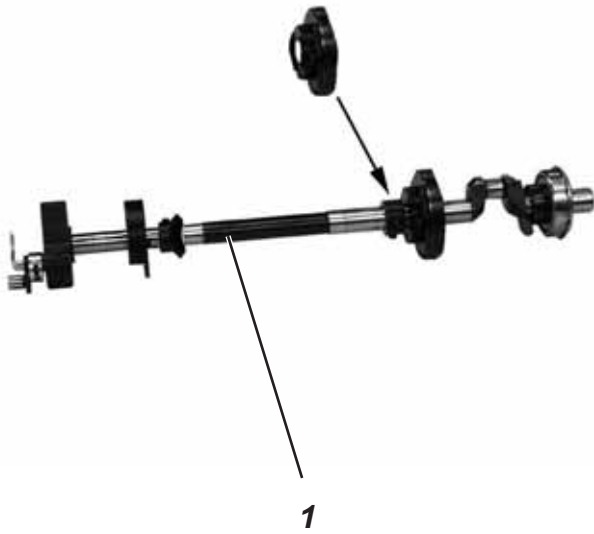

Some of the adjustments at the arm shaft 1 can be carried out easier if the thread trimming mechanism 3 is removed before.



#### **Caution: Danger of injury !**

Switch off main switch.

Remove and mount thread trimming mechanism only when the automatic bartacker is switched off.

#### **Remove mechanism**

- Unscrew arm cover.
- Loosen screw 4 at the thread trimmer magnet.
- Unscrew screws 2 and 5 and take off thread trimming mechanism 3.

#### **Mount mechanism**

- Push thread trimming mechanism 3 on the magnet and place it on the machine head.
- Insert screws 2 and 5 and screw tight.
- Tighten screw 4 at the thread trimmer magnet.
- Adjust thread trimmer (see chapter 5).



## 2.2 Assembly of the crank

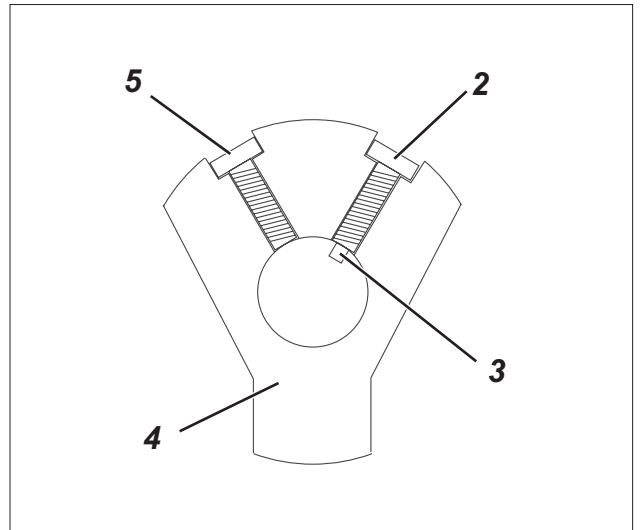
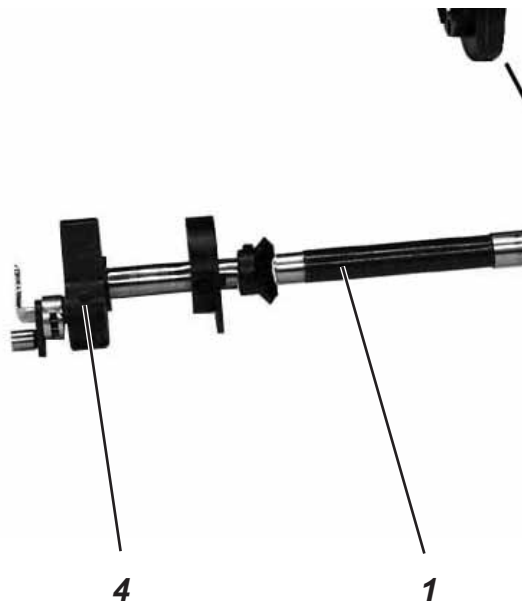

### Caution: Danger of injury !

Switch off main switch.

Remove and mount crank only when the automatic bartacker is switched off.

3

### Standard

The crank 4 has to be mounted on the arm shaft 1 in such a way that the pivot 3 of the screw 2 reaches into the drill-hole on the arm shaft. The screw 2 is the first screw in the direction of rotation.

### Assembly

- Push crank 4 on arm shaft 1.
- Twist crank 4 in such a way that its first drill-hole in the direction of rotation lies above the drill-hole in the arm shaft 1. Insert screw 2 with pivot 3 and screw tight.
- Insert screw 5 and tighten.

## 2.3 Arm shaft position

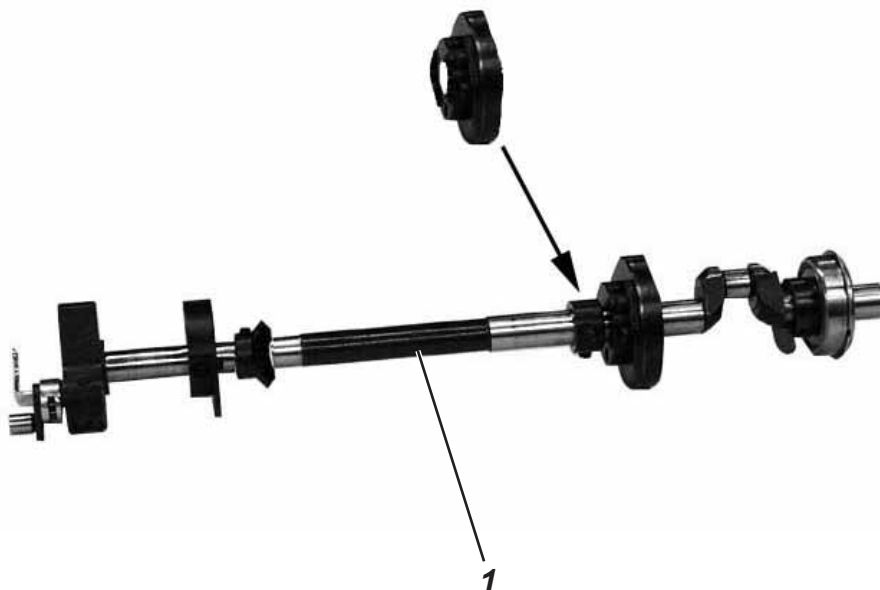

### Caution: Danger of injury !

Switch off main switch.

Check and adjust position of the arm shaft only when the automatic bartacker is switched off.

### Standard checking

The arm shaft 1 should have no axial backlash, but it must not move too heavy.

- Check the arm shaft with regard to axial backlash and rough running.

### Correction

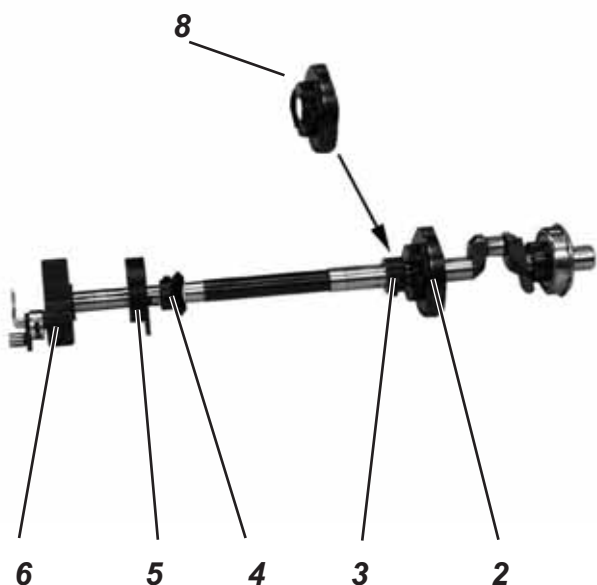

- Loosen screws at the thread trimmer cam 2.
- Loosen screws at the adjusting ring 3 or tension release cam 8.
- Loosen screws at the bevel gear 4.
- Loosen screws at the bobbin winder wheel 5.

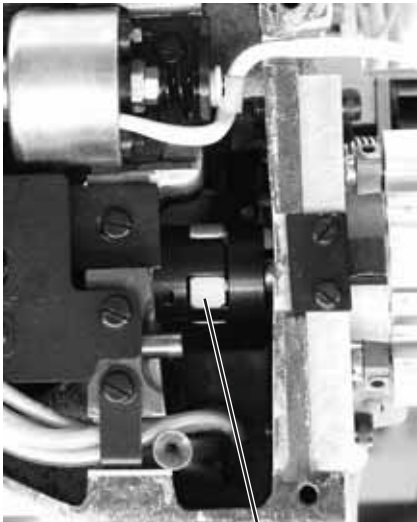
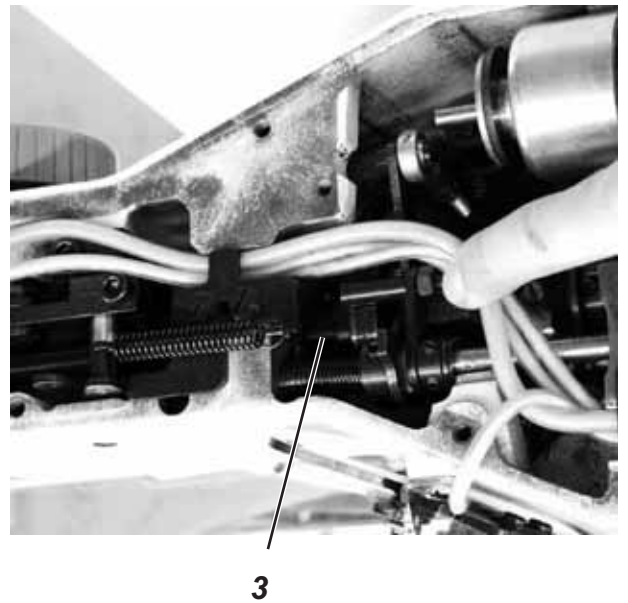
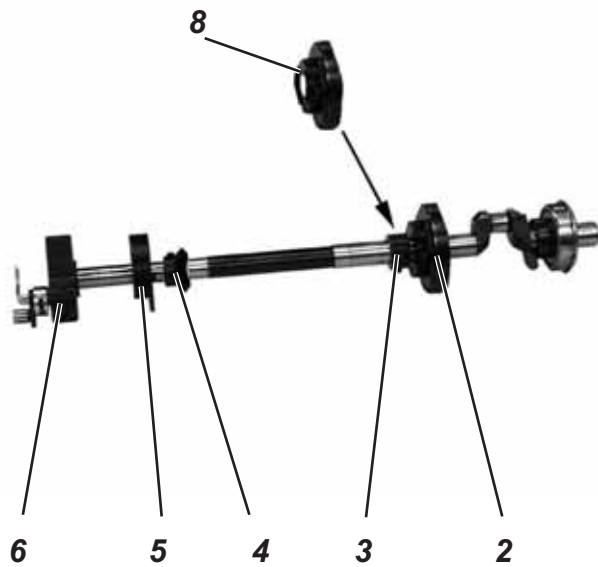

7

- Loosen screw at the motor coupling 7.
- Push arm shaft cam 6 axially to the right as far as it will go.
- Push adjusting ring 3 to the left against the bearing bush and tighten screws.
- Check arm shaft with regard to axial backlash and smooth running.
- Tighten screws at the thread trimmer cam 2 (adjustment see chapter 5).
- Tighten screws at the bevel gear 4 (adjustment see chapter 2.2).
- Tighten screws at the bobbin winder wheel (adjustment see chapter 2.3).
- Tighten screw at the motor coupling 7 (adjustment see chapter 2.6).

## 2.4 Bevel gear for the handwheel

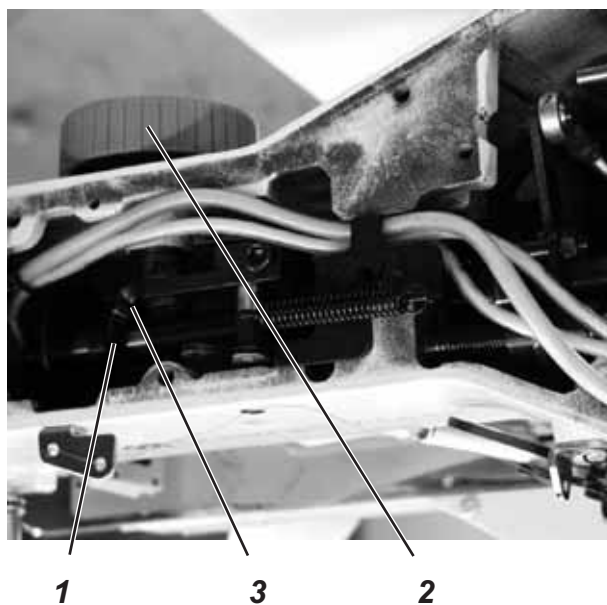
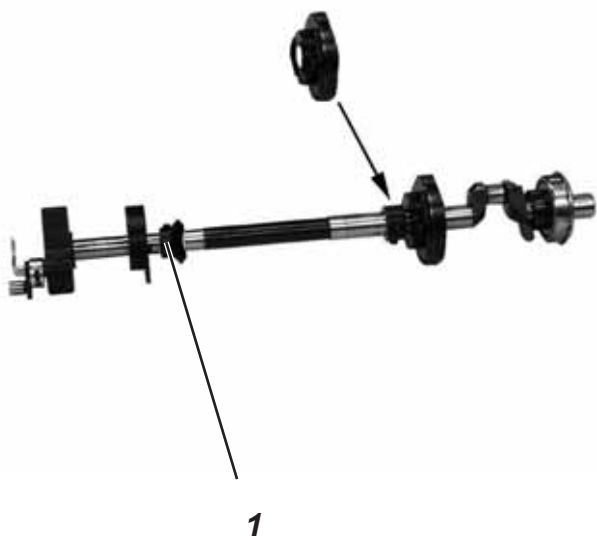

### Caution: Danger of injury!

Switch off main switch.

Check and adjust bevel gear only when the automatic bartacker is switched off.

### Standard checking

The bevel gear 1 has to be positioned on the upper shaft in such a way that - when the handwheel 2 is engaged - there is as little clearance as possible between bevel gear 1 and bevel gear 3.

- Engage handwheel 2.
- Check whether there is as little clearance as possible between bevel gear 1 and bevel gear 3.

### Correction

- Loosen screws at bevel gear 1.
- Engage handwheel 2.
- Press bevel gear 1 against the toothed wheel 3 and tighten fastening screws.
- Turn handwheel and check whether there is as little clearance as possible between bevel gear 1 and toothed wheel 3.

## 2.5 Adjust bobbin winder

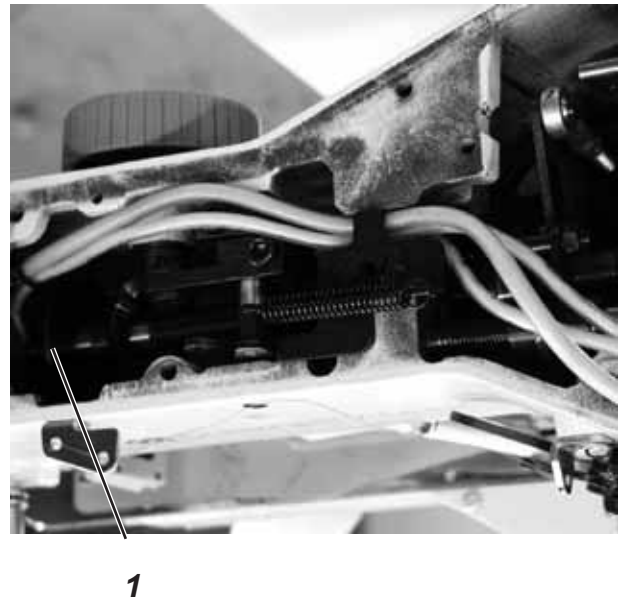

### Caution: Danger of injury!

Switch off main switch.

Check and adjust bobbin winder only when the automatic bartacker is switched off.

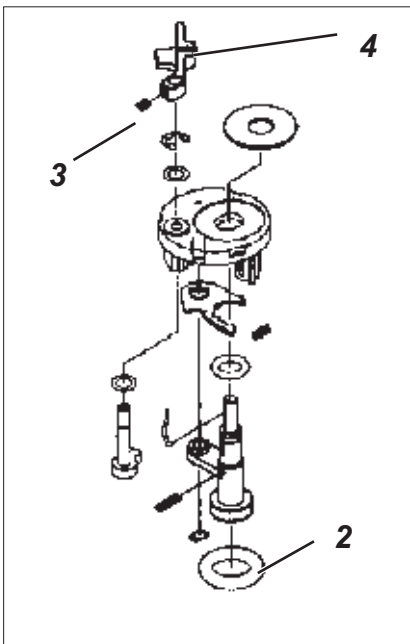

### Standard

The bobbin winding operation must stop automatically when the bobbin is filled up to approx. 0.3 mm below the edge of the bobbin.

### Correction of the bobbin winder wheel

- Loosen screws at the driver wheel 1.
- Shift driver wheel 1 axially in such a way that it abuts on the bobbin winder wheel 2 with the bobbin cover screwed on .
- Tighten screws at the driver wheel 1.  
The second screw in the direction of rotation is located at a spot-faced place.
- Put on head cover and tighten.
- Check bobbin winder and repeat adjustment, if necessary.

### Correction of the bobbin capacity

- Loosen screw 3.
- Adjust bobbin winder clip 4.
- Tighten screw 3.

### Note:

When correcting the driver wheel take care that the oil wicks do not collide with the driver wheel afterwards.

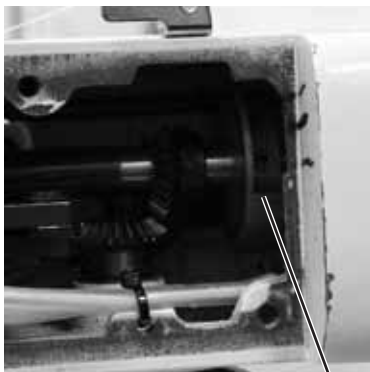

1

## 2.6 Thread trimmer cam

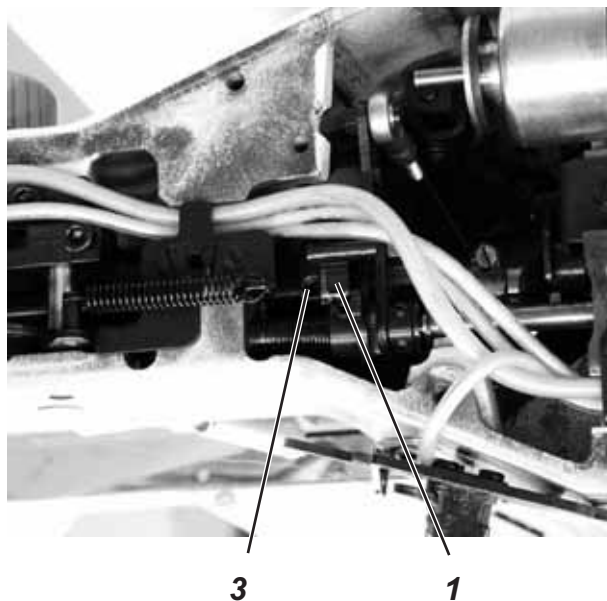
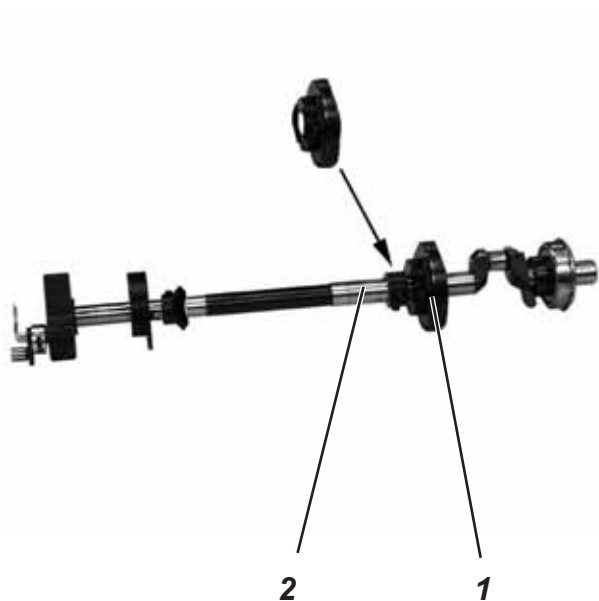

### Caution: Danger of injury!

Switch off main switch.

Check and adjust thread trimmer cam only when the automatic bartacker is switched off.

### Standard checking

The correct position of the thread trimmer cam 1 is marked by a point on the upper shaft 2 and a line on the thread trimmer cam 1.

The position is correct when both markings are standing opposite.

- Engage handwheel and turn until the marking points 4 and 5 on the upper shaft and the thread trimmer cam are visible.
- Check whether both markings are standing exactly opposite.

### Correction

- Loosen screws 3 at the thread trimmer cam.
- Twist and axially shift the thread trimmer cam in such a way that both markings 4 and 5 are standing exactly opposite.
- Tighten screws 3.

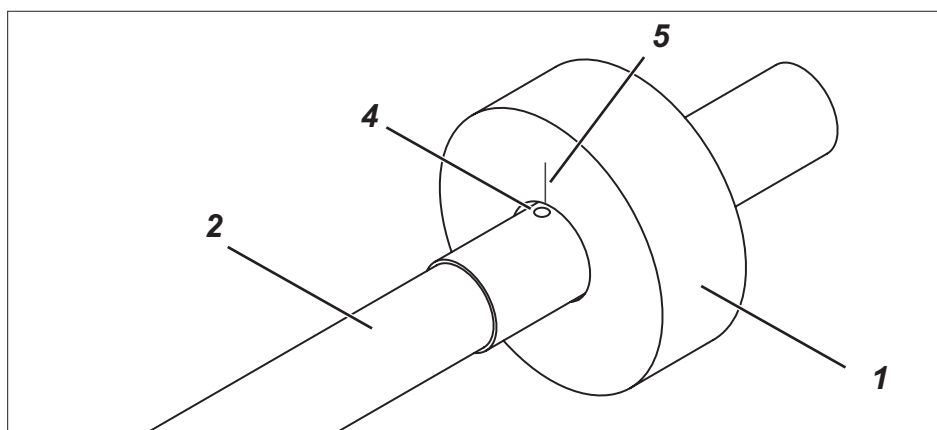

## 2.7 Crankshaft drive to the hook shaft

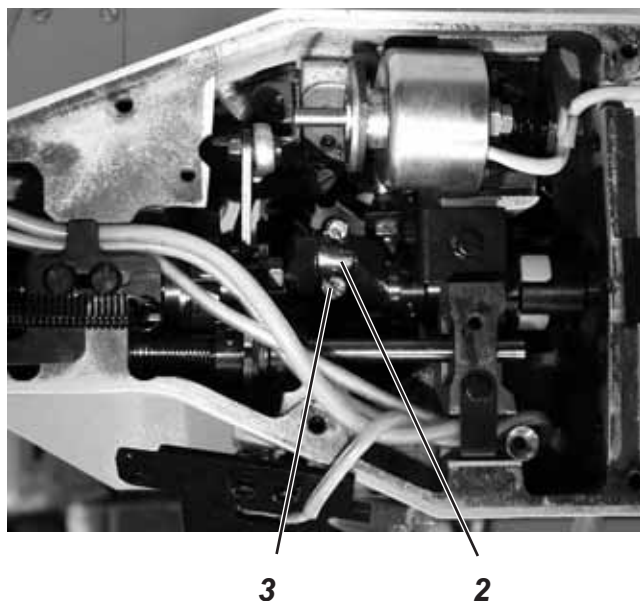

### Caution: Danger of injury!

Switch off main switch.

Check and adjust crankshaft drive only when the automatic bartacker is switched off.

3

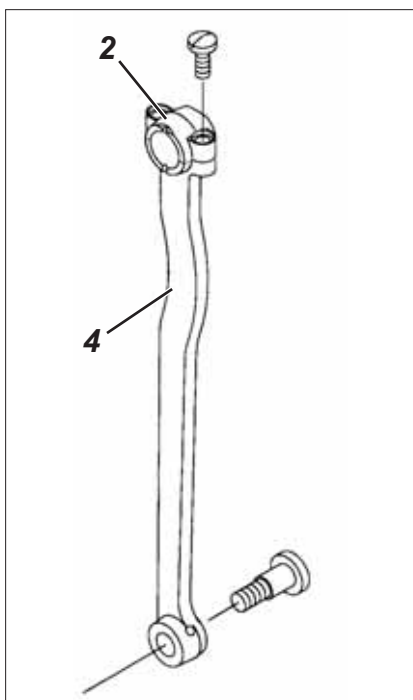

### Standard checking

The arm shaft and the hook shaft are connected by the connecting rod 4 gripping into the crank 1 of the upper shaft.

The connecting rod 4 and the upper bearing shell 2 have a marking on one side. When assembling them the markings must be on the same side.

Connecting rod 4 and bearing shell 2 must not jam when being screwed together.

- Check whether the markings are on the same side.
- Tighten screws 3 equally.



## 2.8 Sewing motor coupling

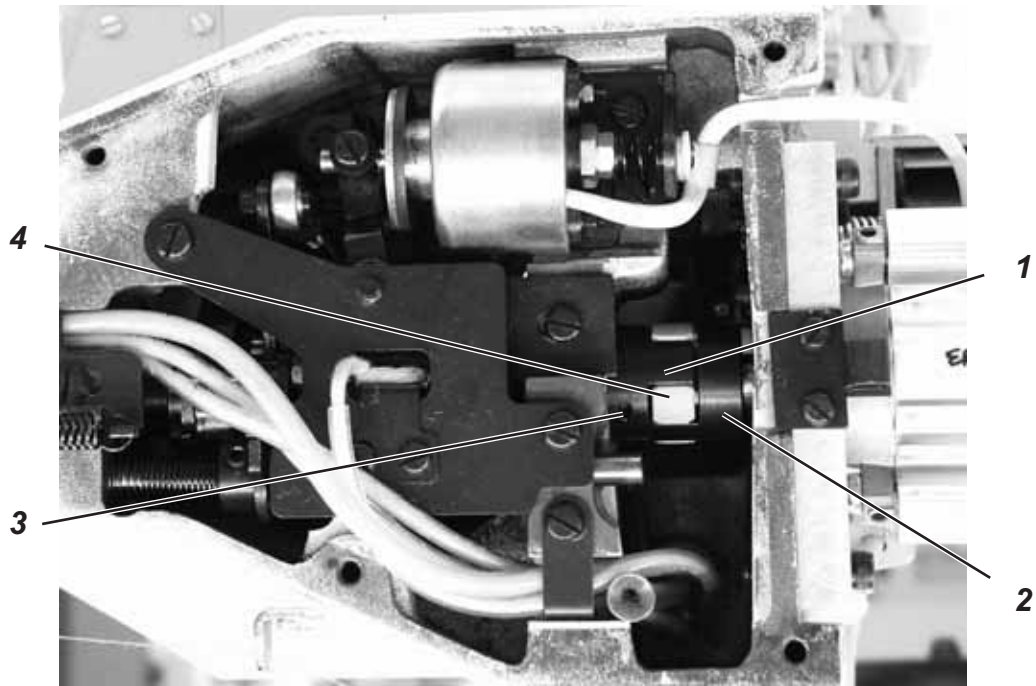

### **Caution: Danger of injury!**

Switch off main switch.

Check and adjust sewing motor coupling only when the automatic bartacker is switched off.

### **Standard checking**

Both coupling halves 1 and 2 must be positioned in such a way that the knobs of the cam 4 abut on the left or on the right.

- Rotate arm shaft with the handwheel and check whether the cam has enough clearance in every position.

### **Correction**

- Loosen screw 3 at the coupling.
- Adjust coupling piece 1 on the shaft axially.
- Tighten screw 3 again.
- Check clearance in the coupling.



## 2.9 Reference position of the sewing motor

### 2.9.1 Position of the initiator



#### **Caution: Danger of injury!**

Switch off main switch.

Check and adjust initiator only when the automatic bartacker is switched off.

#### **Standard checking**

The distance between the initiator 1 and the largest outer diameter of the 180° disc 3 should be as small as possible.

#### **Correction of the distance between the 180° disc and the initiator**

- Loosen counter nuts 4 and 5 at the initiator 1.
- Set the smallest possible distance between initiator 1 and the largest outer diameter of the 180° disc 3.
- Tighten counter nuts 4 and 5 at the initiator.

## 2.9.2 Adjust reference position

The adjustment of the correct reference position of the sewing motor is done with the help of the adjusting aid in the control.

### Call up adjusting aid

The adjusting aid shows the correct position of crank 1.

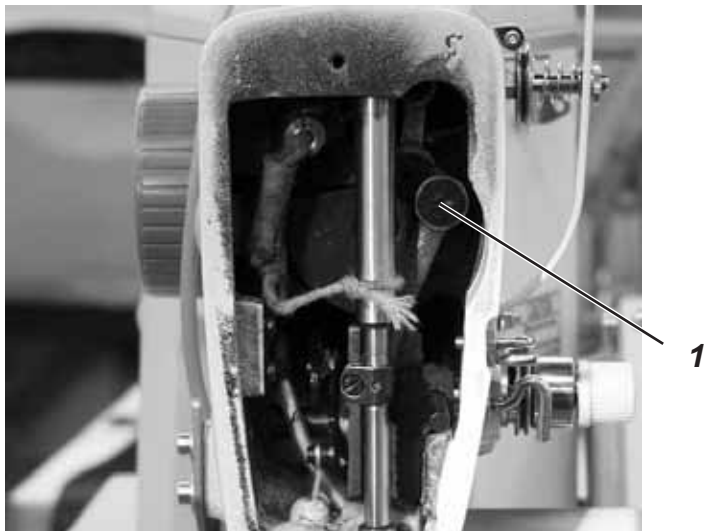

- Switch on main switch.  
The control is initialized.  
The main menu appears.

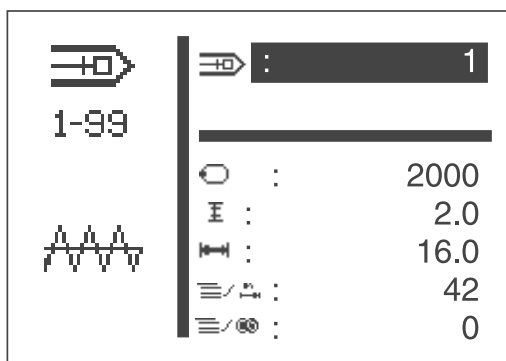

- Press function key “F” when the main menu is displayed.
- Enter code number “25483”.
- Press key “OK”.  
After entry of the correct code number the display changes over to the menu “Technician mode”.

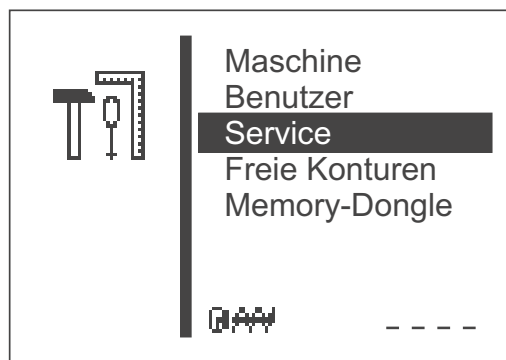

**machine config**  
**user settings**  
**service**  
**free contours**  
**memory dongle**

- Select menu "**Test functions**" with key "↓".
- Start menu with the key "**OK**".  
The menu for the test functions appears.



multitest  
180°-disc  
events  
DAC III  
init

- Select menu "180° disc" with the keys "↑" or "↓".
- Start menu with the key "**OK**".  
The following menu appears:

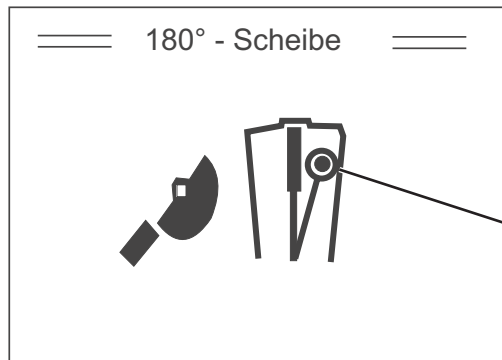

180°-disc

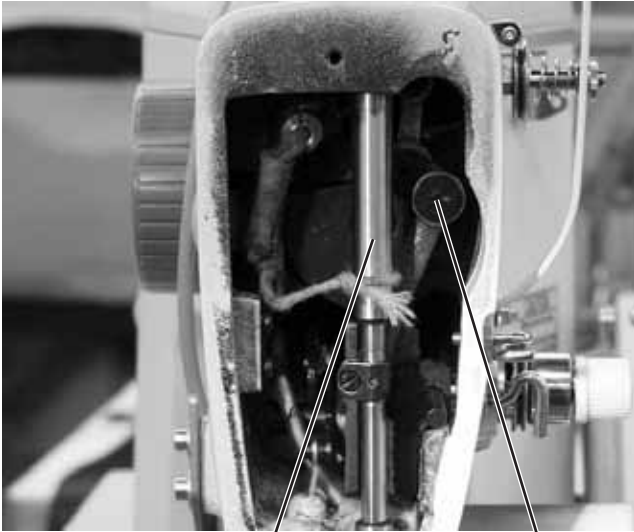

2

1

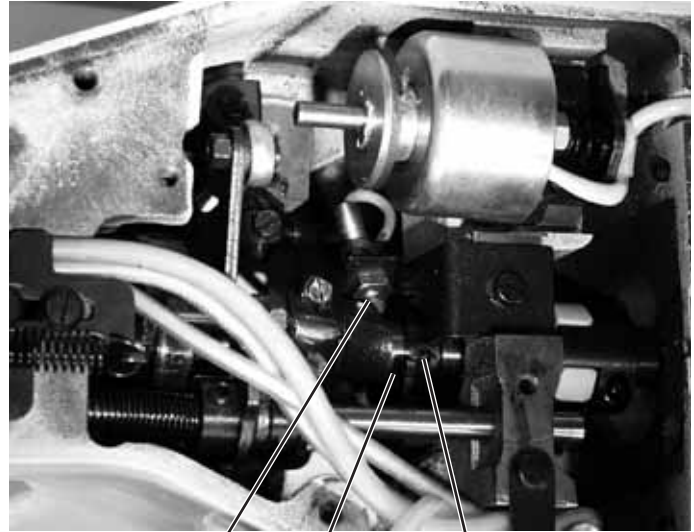

5

4

3

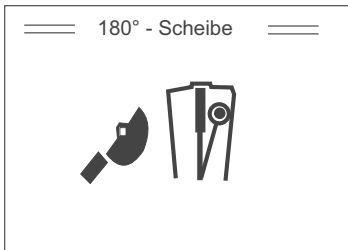

### Adjust 180° disc

- Loosen screw 3 at the 180° disc 4.
  - Turn crank 1 by hand into the position indicated in the display.
  - Place the front side of the 180° disc centrally on the initiator 5 in said position.
  - Tighten screw 3 at the 180° disc.
  - Press the **"RST"** key (BF2) or the **"OK"** key (BF3).  
If the adjustment is correct, the automatic bartacker positions in such a way that the crank 1 is exactly behind the needle bar bush 2.
- The following menu appears:

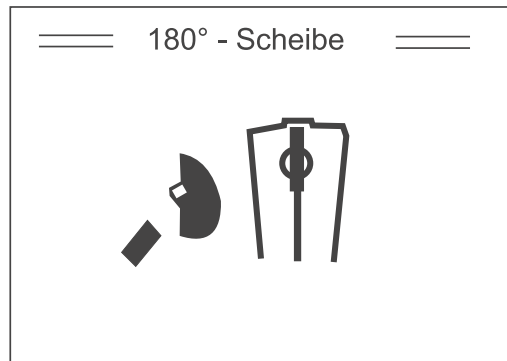

**180°-disc**

- Check whether the needle bar crank is in the position as indicated in the menu.
- Correct position of the 180° disc, if necessary. For this purpose press **"RST"** key (BF2) or the **"OK"** key (BF3), then correct the 180° disc correspondingly.
- Afterwards press **"RST"** key (BF2) or the **"OK"** key (BF3) three times in order to go to the altered reference position.
- Check whether the crank 1 is in parallel position to the needle bar bush 2.
- If necessary, repeat the procedure.

### 3. Hook, looping stroke and needle bar height

#### 3.1 Driver shaft

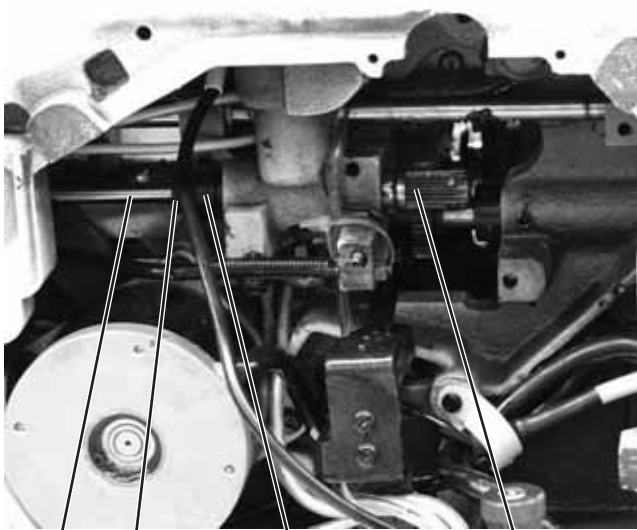

4 3 2 1



9 8 7 6 5



#### **Caution: Danger of injury!**

Switch off main switch.

Check and adjust driver shaft only when the automatic bartacker is switched off.

3

#### **Standard checking**

The driver shaft 4 should have no axial backlash, but it must not move too heavy.

- Check the driver shaft 4 with regard to axial backlash and rough running.

#### **Correction**

- Unscrew screws 5 and 7 and take off oil felt 6.
- Loosen screws 9 (4 pieces) at the motor and pull off the motor 8.
- Loosen screws at the adjusting rings 2 and 3.
- Press driver shaft 4 with toothed wheel 1 completely in the direction of the needle bar.
- Press adjusting rings 2 and 3 against the bush and tighten screws.
- Check whether the shaft is without clearance and runs smoothly.
- Insert motor 8 and screw tight.
- Tighten oil felt 6 with the two screws 5 and 6.

## 3.2 Gear segment on the camshaft

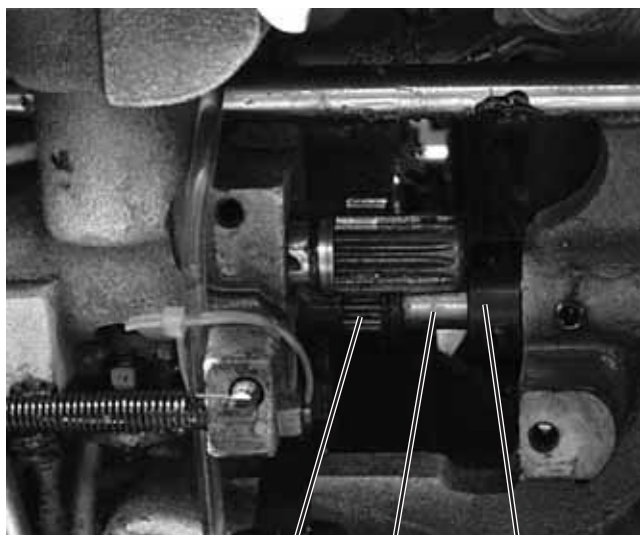

3 2 1

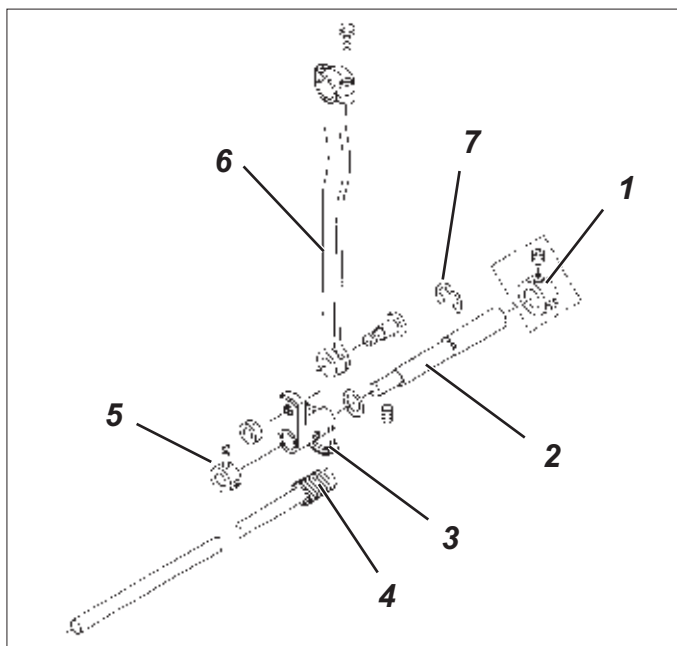

### Caution: Danger of injury!

Switch off main switch.

Check and adjust gear segment only when the automatic bartacker is switched off.

### Standard checking

The gear segment 3 should have no clearance on the camshaft 2, but it must not move too heavy.

Gear segment 3 and camshaft 2 must axially stand in such a way that the connecting rod 6 does not jam.

- Check gear segment with regard to axial backlash and rough running.
- Check whether the connecting rod 6 does not jam.

### Correction of the gear segment on the camshaft

- Loosen screws at the adjusting ring 5.
- Push gear segment 3 to the very right against the locking ring 7.
- Push the adjusting ring to the gear segment and tighten screws.
- Check gear segment with regard to axial backlash and rough running.

### Correction of the gear segment to the crankshaft drive

- Loosen screws at the adjusting ring 1.
- Shift gear segment 3 with camshaft 2 laterally in such a way that the connecting rod 6 is in the clearance center as far as possible.
- Push the adjusting ring to the right against the casing.
- Tighten screws at the adjusting ring 1.
- Check whether the connecting rod 6 does not jam.

### 3.3 Gear segment to the driver shaft

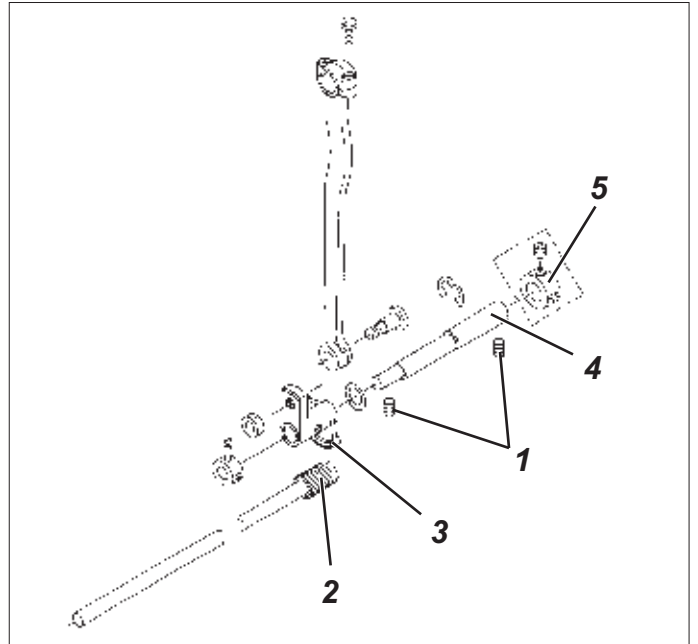
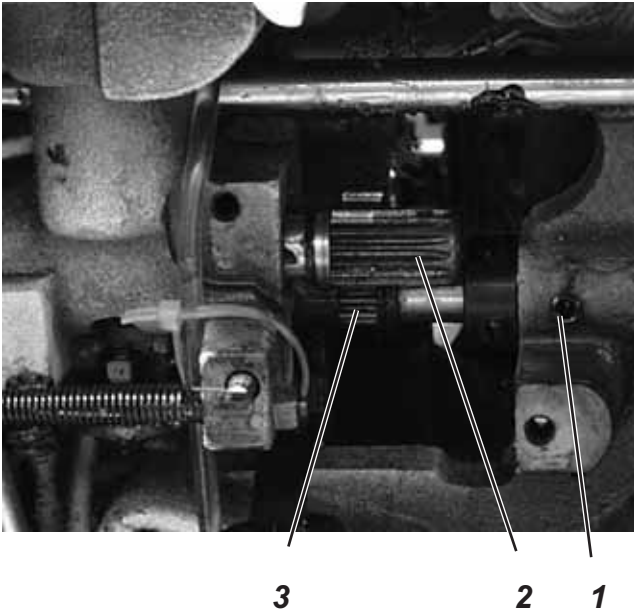

#### **Caution: Danger of injury!**

Switch off main switch.

Check and adjust gear segment only when the automatic bartacker is switched off.

#### **Standard checking**

The gear segment 3 should grip into the toothed wheel 2 of the driver shaft with the smallest clearance possible, but it must not move too heavy.

- Turn handwheel and check clearance between gear segment 3 and toothed wheel 2.

#### **Correction**

- Loosen Allen screws 1.
- Twist camshaft 4 counter-clockwise until the clearance between gear segment 3 and toothed wheel 2 is as small as possible.
- Turn handwheel and check clearance between gear segment 3 and toothed wheel 2.
- Press the adjusting ring 5 to the right against the casing.
- Tighten Allen screws 1.

### 3.4 Needle bar height



2

1

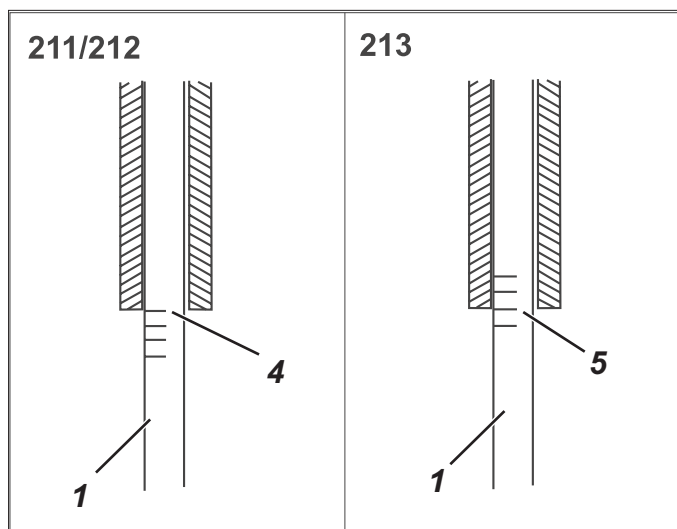

#### Caution: Danger of injury!

Switch off main switch.

Check and adjust needle bar height only when the automatic bartacker is switched off.

#### Standard checking

The needle bar 1 is provided with four notches as adjusting aid.

The two notches on the higher position are for the needle system DPx5 (510-211/-212), those on the lower position are for the needle system DPx17 (520-213).

When the needle bar is in its lowest position, the upper notch 4 (DPx5) or 5 (DPx17) should be on the same level with the bottom of the needle bar bush.

- Move needle bar in its lowest position.
- Check whether the upper notch 4 is at the same level with the bottom of the needle bar bush.

#### Correction

- Loosen needle bar fastening screw 2.
- Adjust needle bar 1 height.  
Make sure that the needle bar 1 is not twisted.
- Tighten needle bar fastening screw 2.



### 3.5 Distance between hook tip and needle

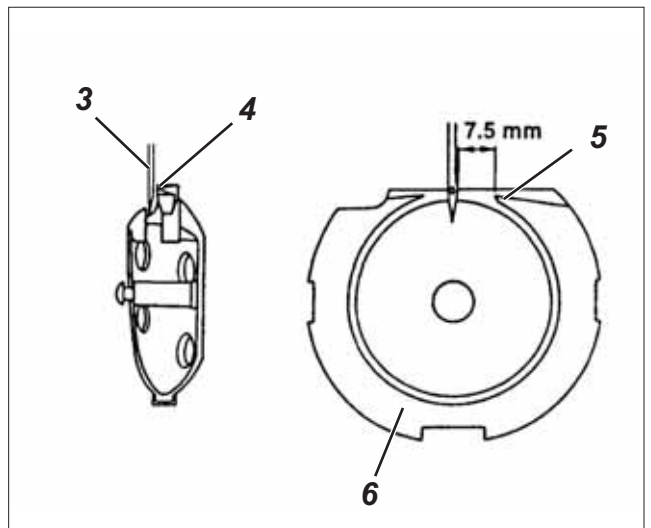
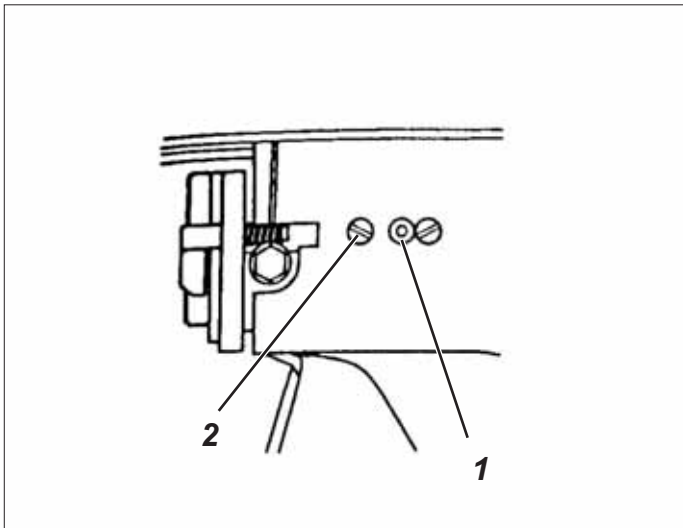

#### Caution: Danger of injury!

Switch off main switch.

Check and adjust distance between hook tip and needle only when the automatic bartacker is switched off.

#### Standard checking

The hook tip 4 must stand as close as possible to the hollow groove of the needle 3, however, without touching it.

The tip 5 of the hook path bearing 6 should have a distance of 7.5 mm to the right side of the needle.

- Remove bobbin case top part with bobbin.
- Insert a new, straight needle 3.
- Move hook tip 4 up to the hollow groove of the needle 3 by turning the handwheel.
- Check position of the hook tip to the needle.
- Check distance of the tip 5 of the hook path bearing to the right side of the needle.

#### Correction

- Loosen screw 2.
- Adjust hook path bearing 6 axially with the eccentric 1.  
Eccentric to the left = smaller distance between hook tip and needle  
Eccentric to the right = larger distance between hook tip and needle
- Twist hook path bearing 6 in such a way that it has a distance of 7.5 mm to the right side of the needle.
- Tighten screw 2.

### 3.6 Looping stroke and needle protection



7

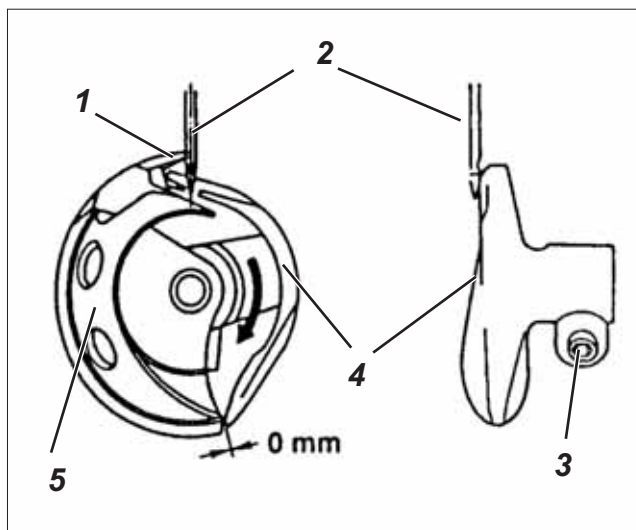

#### Caution: Danger of injury!

Switch off main switch.

Check and adjust looping stroke and needle protection only when the automatic bartacker is switched off.

211/212

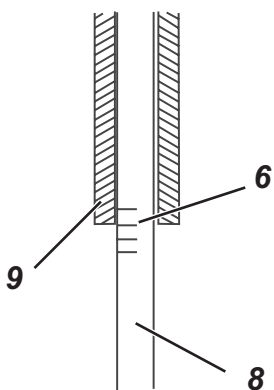

213

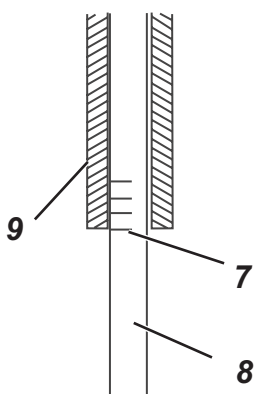

#### Standard checking

The needle bar is provided with four notches as adjusting aid. The two notches on the higher position are for the needle system DPx5 (510-211/-212), those on the lower position are for the needle system DPx17 (520-213).

The looping stroke is the way of the needle 2 from its bottom dead centre to the point where the hook tip 1 is at the level of the middle of the needle.

In looping stroke position, the needle should be pushed away slightly from the driver (needle protection).

- Insert a new, straight needle.
- Move needle bar 8 into its lowest position by turning the handwheel.
- Turn handwheel in rotation direction until the lower notch 6 (DPx5) or notch 7 (DPx17) stands at the bottom of the needle bar bush 9.
- Press hook 5 against the driver 4 in the opposite direction of rotation.
- Check whether the hook tip 1 is at the level of the middle of the needle.
- Check whether the needle is pushed away from the driver tip a little bit (needle protection).

#### Correction

- Loosen screw 3 at the driver 4.
- Twist driver correspondingly.
- Shift driver axially in such a way that the needle abuts on the driver tip and is pushed away a little bit.
- Tighten screw 3.

## 4. Thread-guiding parts

### 4.1 Thread controller spring



2



#### **Caution: Danger of injury!**

Switch off main switch.

Check and adjust thread controller spring only when the automatic bartacker is switched off.

3

#### **Standard checking**

The adjustment standards for spring travel and spring tension refer to normal needle thread sizes.

In case of extremely thick or thin needle threads or fabrics different adjustments may be required.

#### **Spring travel**

The thread controller spring 2 must hold the needle thread under a minor tension from the highest position of the thread lever to the moment the needle's eye penetrates the fabric.

In order to achieve a uniform seam pattern with a low thread tension it is possible to further increase the thread controller spring travel.

The thread controller spring must abut on the stop not before the needle's eye has penetrated the fabric.

#### **Spring tension**

The spring tension should be lower than the needle thread tension.

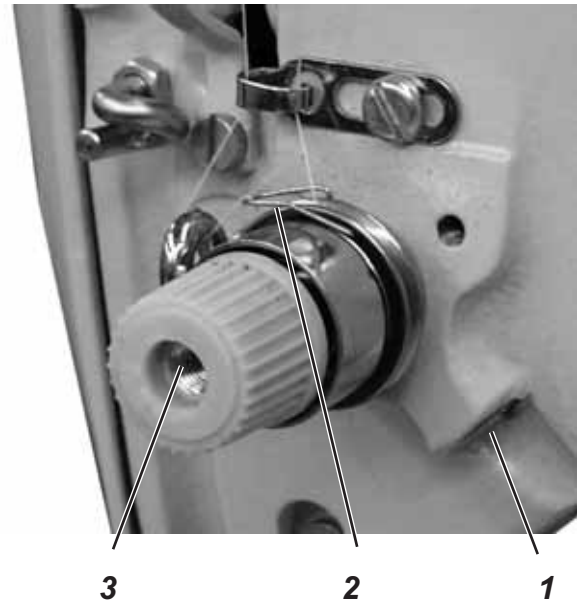
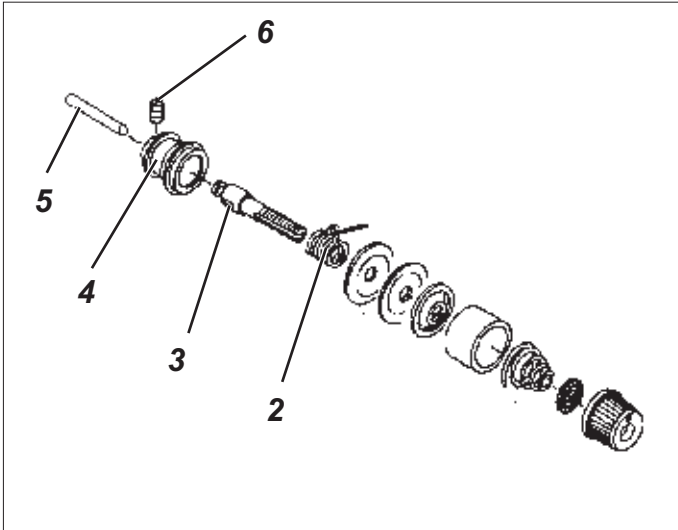

### Correction of the spring tension

- Loosen screw 1.
- Pull out the complete tension unit.  
**ATTENTION !**  
Make sure that the trip pin 5 does not fall out.
- Loosen clamping screw 6.
- Adjust thread tension regulator 3.  
In direction of rotation = higher tension  
In the opposite direction of rotation = lower tension
- Tighten clamping screw 6.
- Insert tension unit and tighten screw 1.

### Correction of the spring travel

- Loosen clamping screw 1.
- Adjust thread tension regulator 3.
- Tighten clamping screw 1.

## 4.2 Thread regulator

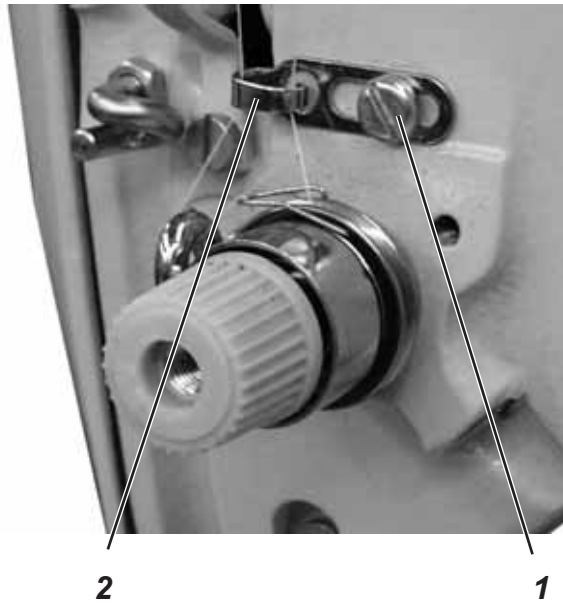

### **Caution: Danger of injury!**

Switch off main switch.

Check and adjust thread regulator only when the automatic bartacker is switched off.

### **Standard checking**

The position of the thread regulator is dependent on the material thickness and the thread size.

It has to be adjusted in such a way that the thread is guided around the hook in a controlled way.

- Load workpiece.
- Thread in needle thread and bobbin thread.
- Tilt automatic bartacker to the left.
- Turn handwheel slowly and observe how tight the needle thread is guided around the hook.

### **Correction**

- Loosen screw 1.
- Shift thread regulator 2.  
Thread regulator to the left = more thread  
Thread regulator to the right = less thread.
- Tighten screw 1.

### 4.3 Change thread wiper

#### 4.3.1 General notes

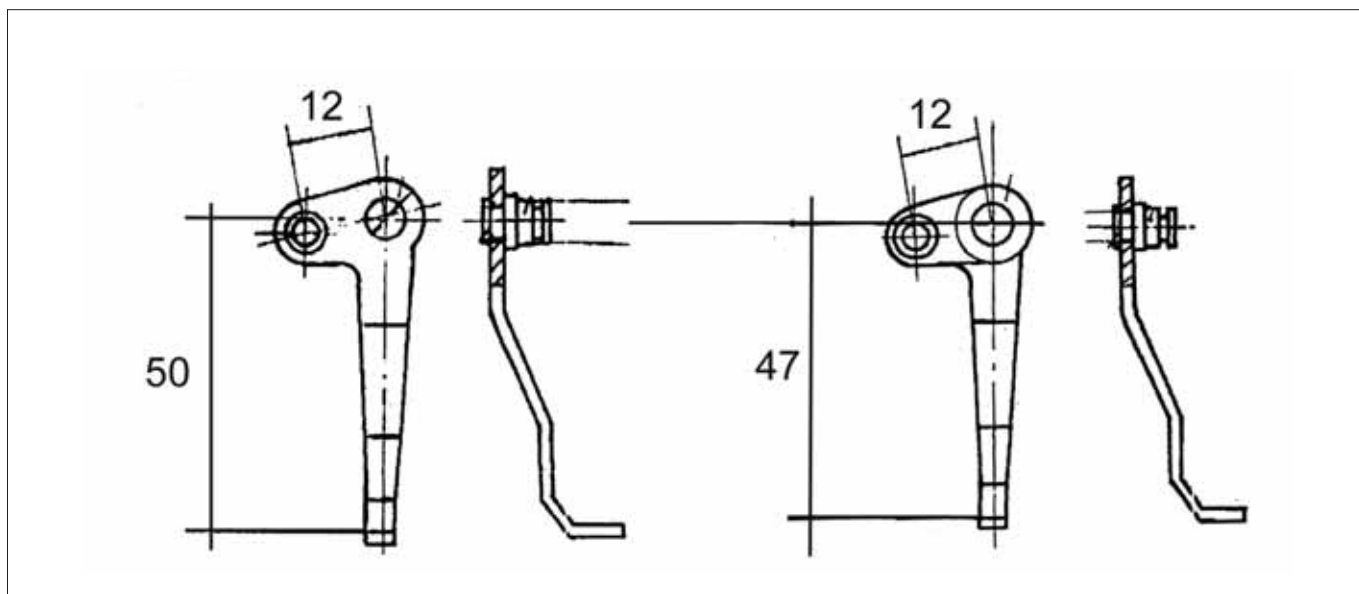

The built-in standard thread wiper is 50 mm long.

The short thread wiper belonging to the accessories is 47 mm long.

### 4.3.2 Remove/mount thread wiper

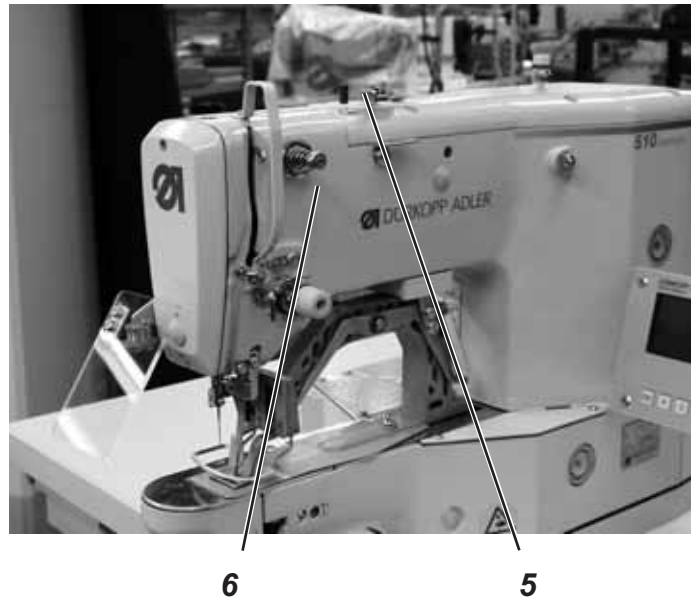
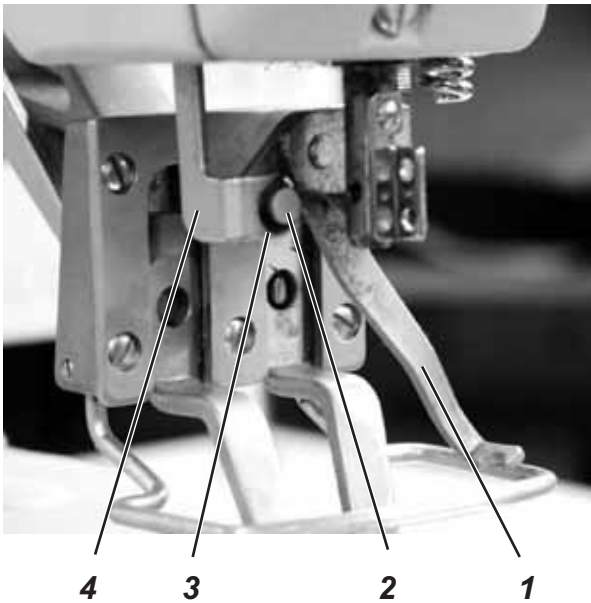

#### **ATTENTION: Danger of breakage !**

When converting the automatic bartacker to thick fabrics change the thread wiper in any case.



#### **Caution: Danger of injury !**

Switch off main switch.  
Change thread wiper only when the automatic bartacker is switched off.

3

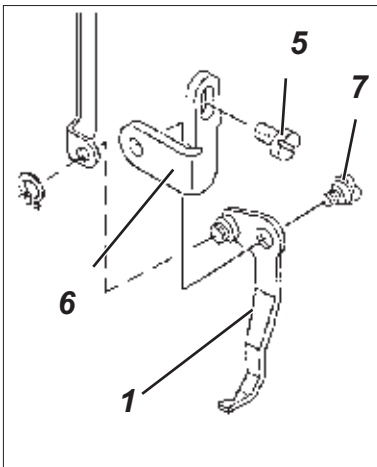

#### **Remove thread wiper (standard thread wiper)**

- Take off locking ring 3 from the bolt 2.
- Unscrew screw 5.
- Carefully push thread wiper holder 6 to the back until bolt 2 is loosened from the fixture 4.
- Take off thread wiper holder with thread wiper.
- Unscrew screw 7 and take off thread wiper 1.

#### **Mount short thread wiper**

- Screw thread wiper 1 with screw 7 on holder 6.
- Insert thread wiper holder 6 with thread wiper 1 into the fixture 4 and tighten with screw 5.
- Put locking ring 3 on bolt 2.
- Set stop position to -15° at the control (see operating instructions chapter 8.5.4.1).

### 4.3.3 Thread wiper height

#### **Standard**

The height of the thread wiper should be set in such a way that it touches neither the needle nor the lifted clamping feet.

- Loosen screw 5.
- Adjust height of the thread wiper.
- Tighten screw 5.
- Check thread wiper movement.

## 5. Thread trimmer

### 5.1 Thread trimmer magnet

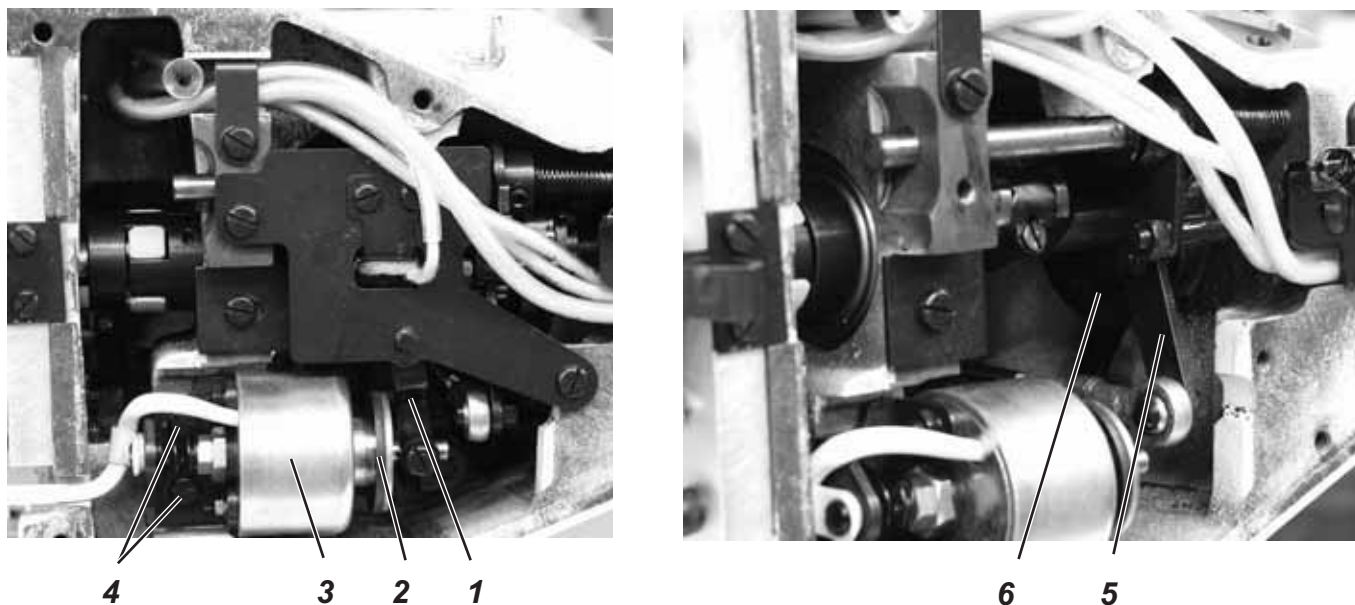

#### **Caution: Danger of injury!**

Switch off main switch.

Check and adjust thread trimmer magnet only when the automatic bartacker is switched off.

#### **Standard checking**

The magnet 3 pushes the lever 5 with the roller bolt into the thread trimmer cam 6 by means of lever 1.

When the roller bolt is pushed in, it must have some axial clearance in the cam.

- Push magnet shaft 2 into the magnet and check whether there is some clearance between the roller bolt and the thread trimmer cam.

#### **Correction**

- Loosen screws 4.
- Press together magnet shaft 2 and magnet 3.
- Then shift the magnet to the left as far as it will go.
- Shift magnet back minimally.
- Tighten screws 4.
- Check whether there is some clearance between the roller bolt and the thread trimmer cam when the roller bolt is pushed in.



## 5.2 Position of the hook knife

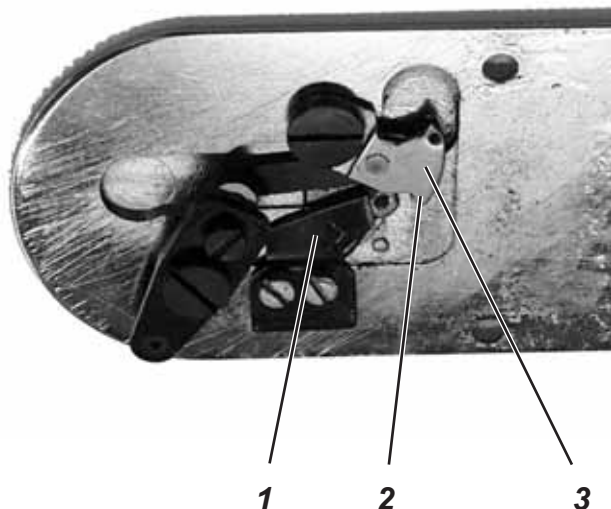
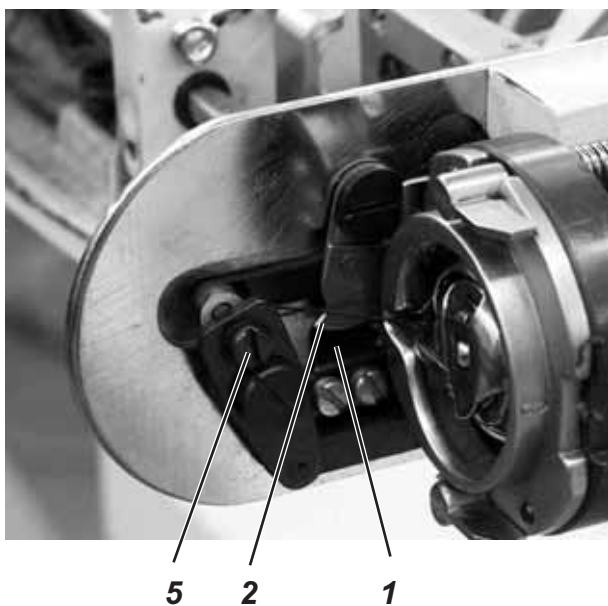

### Caution: Danger of injury!

Switch off main switch.

Check and adjust position of the hook knife only when the automatic bartacker is switched off.

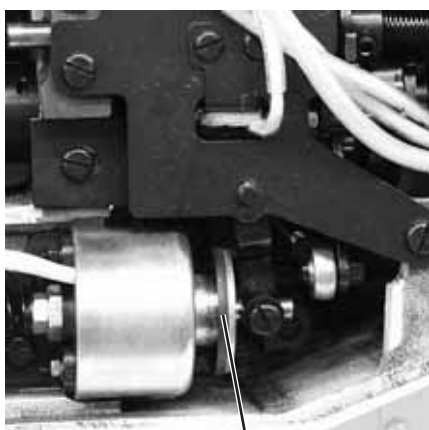

4

### Standard checking

In resting position the point 2 of the hook knife 3 should stand on the left side of the stationary knife 1.

When the hook knife 3 is swivelled in, it must stand on the right thus far that the sewing threads are safely caught by the knife point 2.

- Check whether the point 2 of the hook knife 3 in resting position stands at the left edge of the stationary knife 1.
- Turn handwheel until the thread lever stands a little bit behind its highest position.
- Push magnet 4 to the left and push roller bolt into the thread trimmer cam.
- Turn handwheel slowly until the hook knife is swivelled out completely.
- Check whether the sewing threads are safely caught by the knife.

### Correction

- Loosen screw 5.
- Adjust hook knife correspondingly.
- Tighten screw 5.

### 5.3 Cutting pressure / Position of the stationary knife



3

2

1



5

4



#### **Caution: Danger of injury!**

Switch off main switch.

Check and adjust stationary knife only when the automatic bartacker is switched off.

#### **Standard checking**

The thread trimmer lever 2 should have a distance of 18.5 mm to the front edge of the throat plate 3.

There must be a distance of 0.5 mm between the needle hole 4 and counter-knife 5.

The knife 1 should be aligned in such a way that both threads are safely cut in the middle of the cutting area and with the lowest possible pressure.

A low cutting pressure ensures a low wear and tear of knives.

- Measure the distance between the thread trimmer lever 2 and the front of the throat plate 3.
- Measure the distance between the needle hole 4 and the counter-knife 5.
- Turn handwheel until the hook knife can be swivelled in manually.
- Swivel out hook knife.
- Lay two threads to be cut in the hook knife.
- Turn the handwheel until the hook knife has swivelled back.
- Check whether the sewing threads are neatly cut.



3 2 6

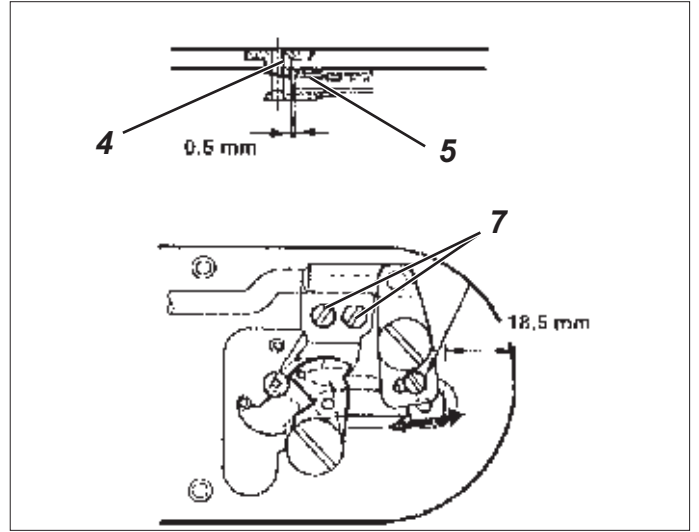

### Correction

#### Basic adjustment of thread trimmer lever 2

- Loosen screw 6.
- Adjust a distance of 18.5 mm between thread trimmer lever 2 and the front of throat plate 3.
- Tighten screw 6.

#### Counter-knife

- Screw out screws 7 and take off knife 5.
- Prepare the knife for the correct cutting pressure.
- Insert knife and align it in such a way that the sewing threads are cut in the middle of the blade.
- Make sure to have a distance of 0.5 mm between needle hole 4 and counter-knife 5.
- Insert and tighten screws 7.

## 5.4 Thread guiding sheet

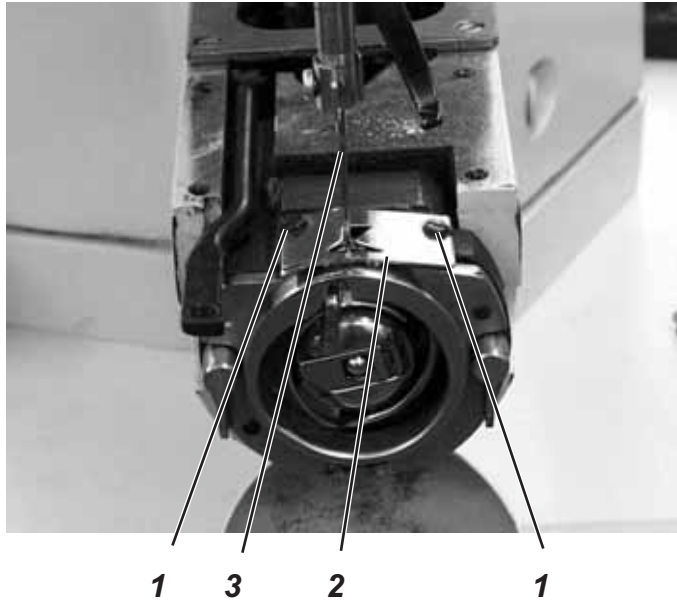

### **Caution: Danger of injury!**

Switch off main switch.

Check and adjust thread guiding sheet only when the automatic bartacker is switched off.

### **Standard checking**

The needle 3 should stand in the center of the cutout of thread guiding sheet 2.

- Check position of the thread guiding sheet

### **Correction**

- Loosen screws 1.
- Align thread guiding sheet as to the needle.
- Tighten screws 1.

## 5.5 Thread tension lifting

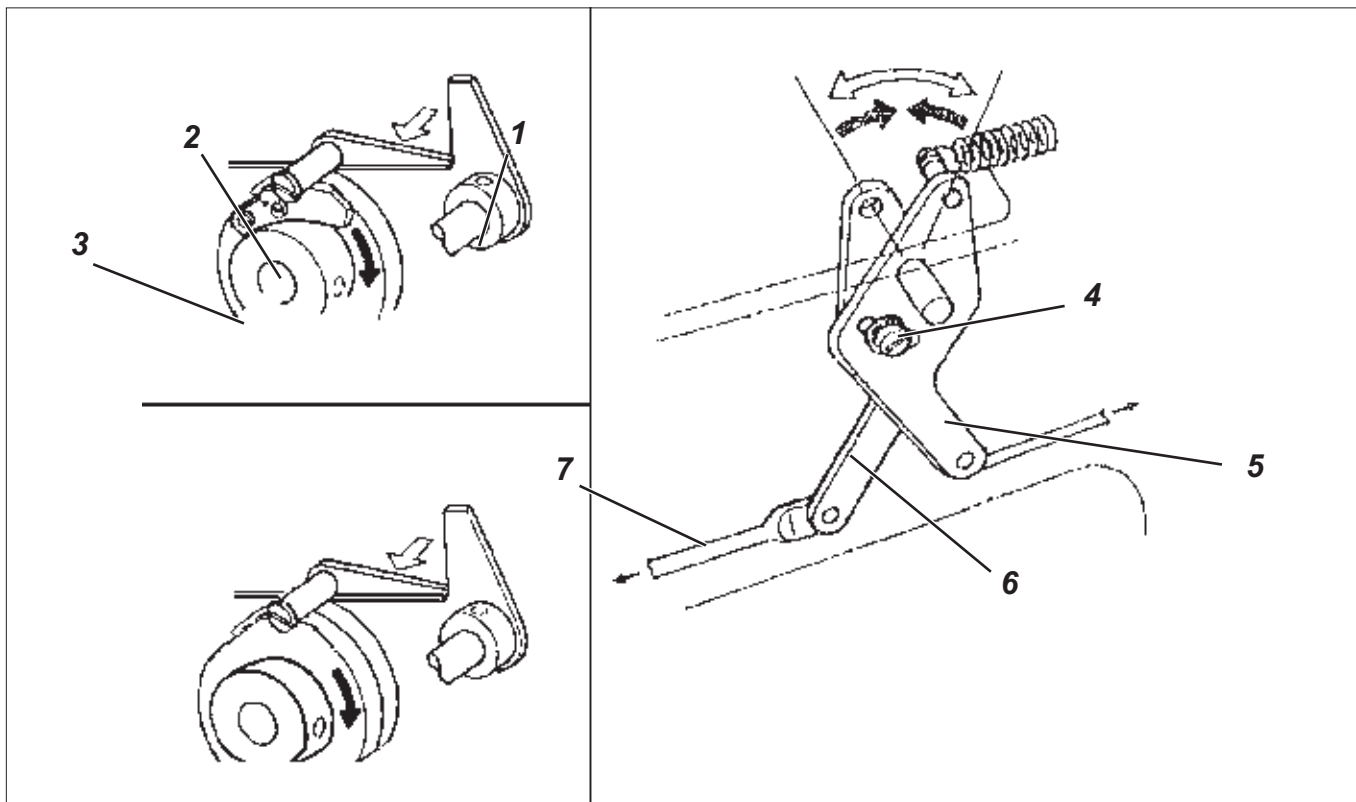

### Caution: Danger of injury!

Switch off main switch.

Check and adjust the thread tension lifting only when the automatic bartacker is switched off.

### Standard checking

The thread tension is opened during thread trimming.

The tension release arm 6 actuates the presser bar 7 and opens the thread tension with the pressure pin.

When trimming the thread the presser bar 7 is actuated by the lever 5.

- Make sure that the tension release finger 2 rests on the tension release catch 3.  
If the finger does not rest on the catch, push the cam pestle 1 in the direction of arrow manually and turn the main shaft in the direction of rotation until the position is reached.
- Loosen clamping screw 4.
- Adjust the tension release arm 6 correspondingly.  
Reduce the distance between arm 5 and arm 6 = the tension discs open wider.  
Increase the distance between arm 5 and arm 6 = the tension discs open less.
- Tighten clamping screw 4.

## 6. Material feed

### 6.1 Gauge for reference position

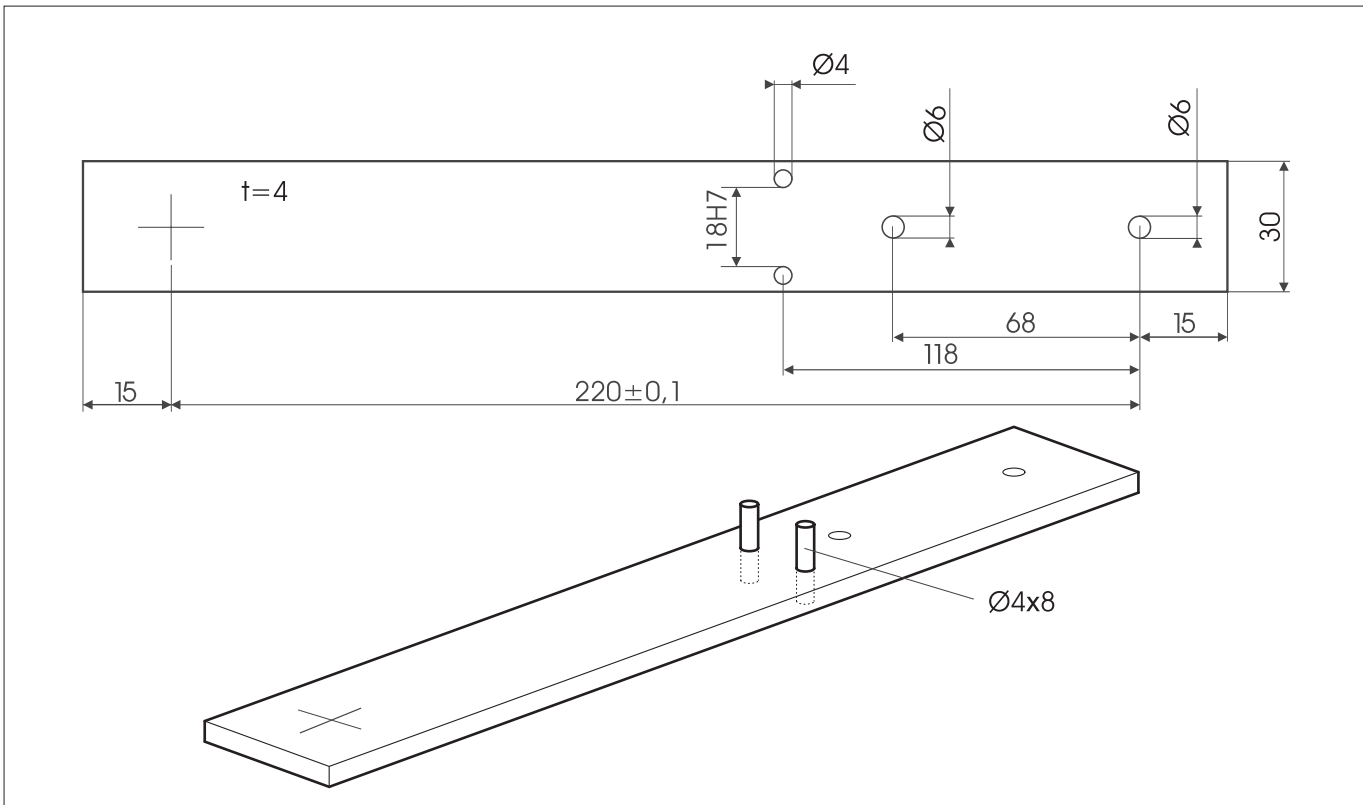

- For setting the reference position the gauge shown above is required.  
The gauge cannot be ordered from Dürkopp Adler.
- Make a gauge according to the above sketch.

## 6.2 Reference position



4 3 2 1

5



### Caution: Danger of injury!

Switch off main switch.

Check and adjust reference position with utmost caution when the automatic bartacker is switched on.

### Standard checking

The movement of the clamping arm 2 and the rest plate 4 is effected by two step motors.

The feed plate 5 carries the clamping arm and the rest plate.

- Press function key "F" when the main menu is displayed.
- Enter code number "25483".  
The display changes over to the technician mode.
- Activate the menu "Machine/Parameter" with the key "OK".

	Absch.dz.: 250
	Max.Dz. : 2700
	Stoppo.s.: 0
	Einlegepos : A
	Referenz.: 1

cut.rpm  
max.rpm  
stop pos.  
sew.st.pt.  
ref.freq.

- Select parameter "Loading position".
- Select function "B = Machine zero position".
- Press "OK" key.  
The automatic bartacker positions in the machine zero position.
- Switch off main switch.
- Unscrew screws 1 and 3.
- Take off clamping arm 2 and rest plate 4.

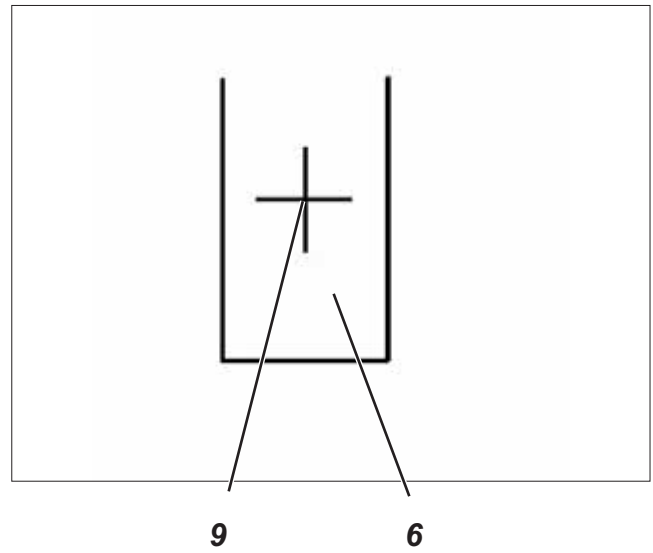
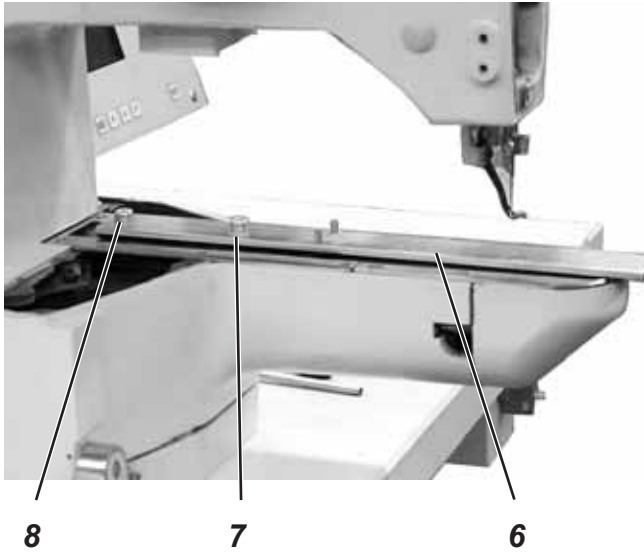

- Screw on gauge 6 (see chapter 6.1) with the two screws 7 and 8.
- Switch on main switch.  
The machine head positions in the machine zero position.
- Move needle bar down by handwheel and check whether the needle points to the marking 9 on the gauge 6.

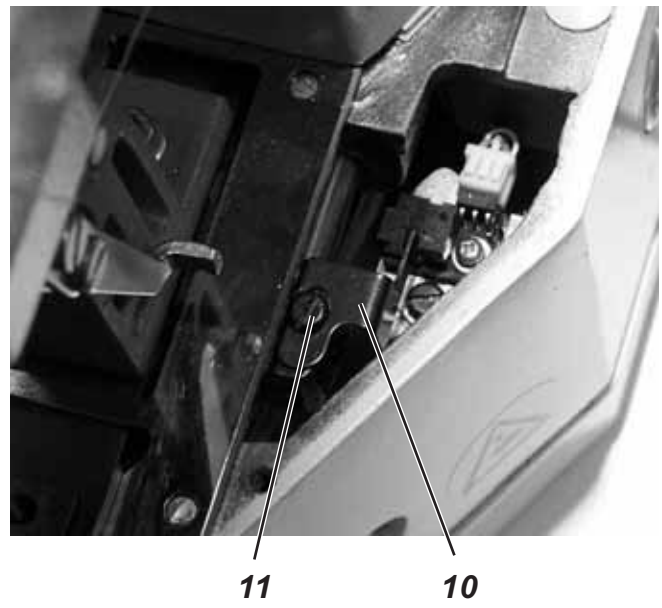
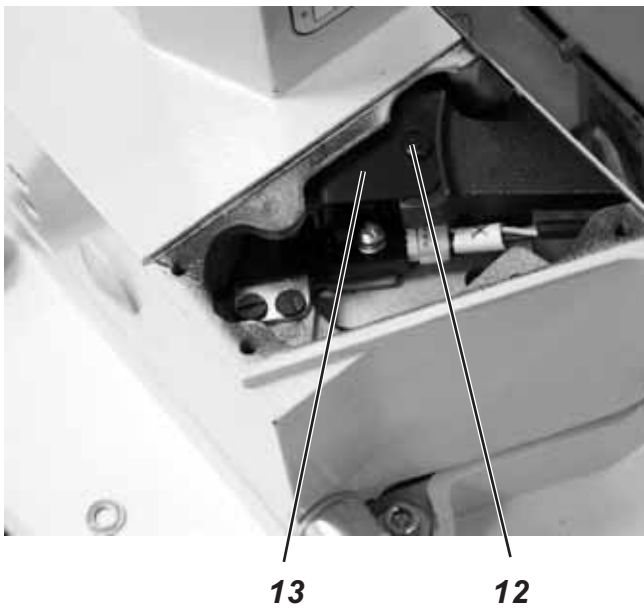

**Correction of the Y-axis**

- Loosen screw 11.
- Adjust switch lug 10 correspondingly.
- Tighten screw 11.

**Correction of the X-axis**

- Loosen screw 12.
- Adjust switch lug 13 correspondingly.
- Tighten screw 12.

- Switch main switch off and on again.  
The automatic bartacker positions in the machine zero position.
- Move needle bar down by handwheel and check whether the needle points to the marking 9 on the gauge 6.



### 6.3 Position of the fabric clamps and the rest plate to the needle



3 2 1



5 4



#### Caution: Danger of injury!

Switch off main switch.

Check and adjust rest plate only when the automatic bartacker is switched off.

#### Standard checking

The movement of the clamps 2 and 3 and the rest plate 1 is effected by two step motors.

The seam pattern sizes can only be altered within the fabric clamps.

The position of the fabric clamps and the rest plate is adjusted in the loading position "B".

- In the seam pattern menu, set the speed to 0, press the pedal and turn the machine manually.  
Simultaneously check the position of the penetrating needle as to the fabric clamps and the rest plate.

#### Correction

- Press function key "F" when the main menu is displayed.
- Enter code number "25483".  
The display changes over to the technician mode.
- Activate the menu "Machine/Parameter" with the key "OK".
- Select parameter "Loading position".
- Select function "B = Machine zero position".
- Press the "OK" key.  
The automatic bartacker positions in the machine zero position.
- Switch off main switch.
- Loosen screws 4 and 5.
- Align clamping arm and rest plate correspondingly.
- Tighten screws 4 and 5.

## 6.4 Fabric clamp lifting



2

1



4

3



### Caution: Danger of injury!

Check and adjust the fabric clamp lifting with utmost caution when the automatic bartacker is switched on.

### Standard checking

The fabric clamps should lift according to the material size.

The lifting movements of the right 1 and the left 2 fabric clamp must be uniform.

- Call up test program (see operating instructions chapter 8.5.4.3).
- Activate clamping foot via output element Y1 in the menu “Multitest” and “Output test”.
- Check whether both fabric clamps are lifted equally high.

### Correction of the lifting stroke

- Place an accordingly thick spacer piece under the fabric clamps 1 and 2.
- Loosen screw 4 at the lifting lever 3.
- Lower sewing feet 1 and 2 down on the spacer piece.
- Tighten screw 4.
- Remove spacer piece and check lifting stroke.

### Correction of the parallel position of the fabric clamps

- Loosen screws 6 or 8.
- Press fabric clamps 1 or 2 downward.
- Align operating lever 5 or 7 and tighten screws 6 or 8.
- Check parallel position of the fabric clamps.



6

5

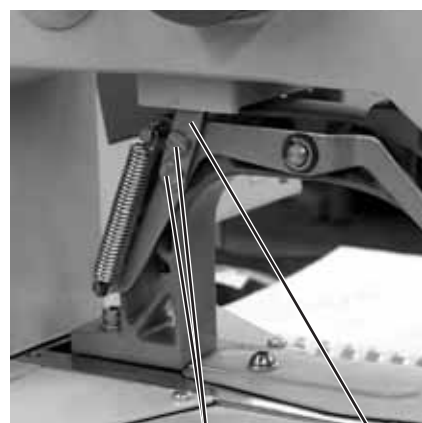

8

7



### ATTENTION: Danger of breakage !

After the clamp height adjustment check the thread wiper height in any case (see chapter 4.3.2).

## 7. Oil lubrication



### Caution: Danger of injury !

Oil can cause skin eruption.  
Avoid a longer contact with the skin.  
Wash yourself thoroughly after a contact.



### ATTENTION !

The handling and disposal of mineral oils is subject to legal regulations.  
Deliver used oil to an authorized collecting station.  
Protect your environment.  
Be careful not to spill any oil.

Oil the automatic bartacker exclusively with the lubricating oil **DA-10** or an equivalent oil with the following specification:

- Viscosity at 40° C: 10 mm<sup>2</sup>/s
- Ignition point: 150° C

**DA-10** can be bought at the sales points of **DÜRKOPP ADLER AG** under the following parts number:

250-ml-Container:	9047 000011
1-Litre-Container:	9047 000012
2-Litre-Container:	9047 000013
5-Litre-Container:	9047 000014

### Lubrication of the automatic bartacker

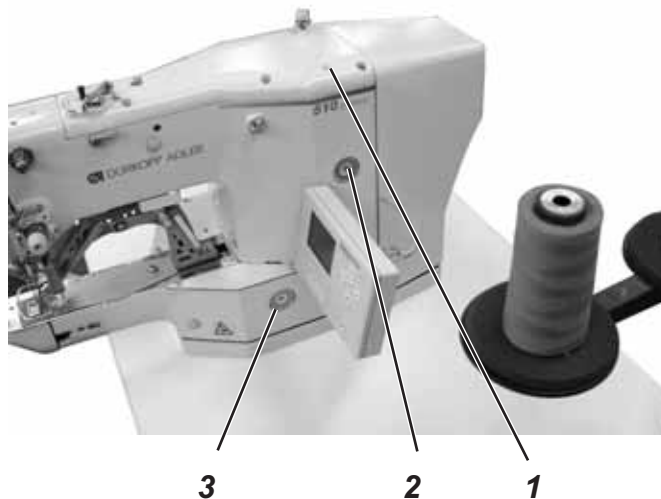

The automatic bartacker is equipped with a central oil wick lubrication.  
The bearings are supplied by the oil reservoirs 2 and 3.

The oil level must not drop below the red marking of both reservoirs.

- Fill up oil through the drill-hole 1 up to the red marking of the reservoir 3.  
The reservoir 3 is filled by the overflow of reservoir 2.

## 7.1 Oil circulation

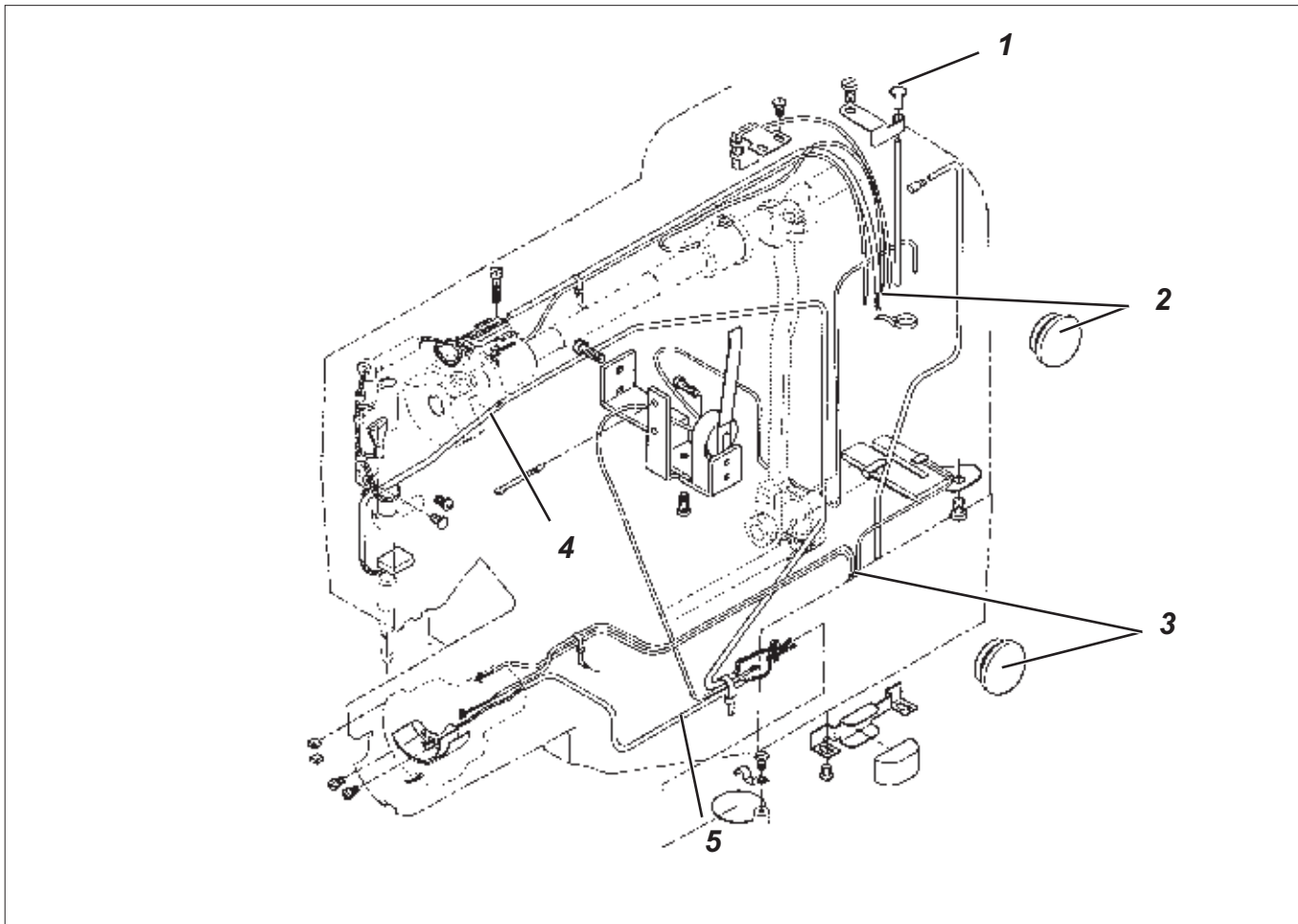

From the filler pipe 1 the oil flows into the oil reservoir 2 and then it runs over into the oil reservoir 3.

All lubricating points of the arm and head zone of the machine are provided with oil by the oil reservoir 2. The oil reservoir 3 supplies all lubricating points of the base plate.

The oil squirting off from the crankshaft drive comes into the oil pan via oil wick 4.

The oil which is not needed by the hook flows back to the oil pan via the return pipe 5.

The squirted oil contained in the oil pan is sucked and delivered back to the oil reservoir 2 by means of a lubricating oil pump.



### **Caution: Danger of injury !**

Switch off main switch.

Carry out assembly work on the oil circulation only when the automatic bartacker is switched off



### **ATTENTION !**

When carrying out assembly work please observe in any case that the hose ends and wicks are fixed to the correct connections again.

## 7.2 Lubricating oil pump

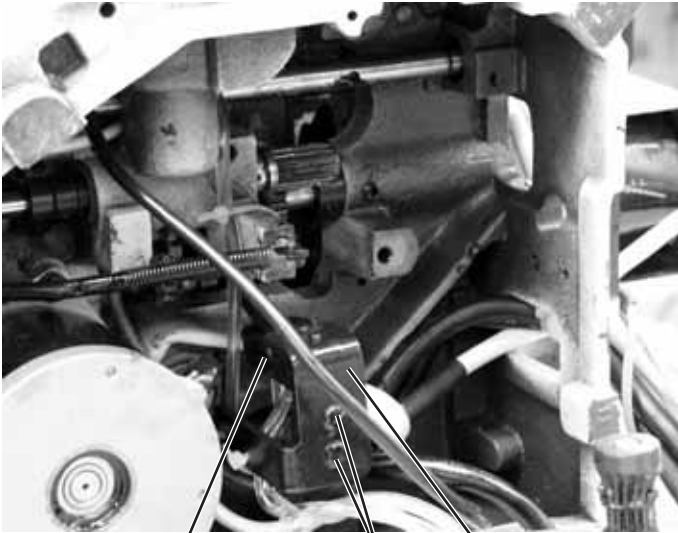

3

2

1

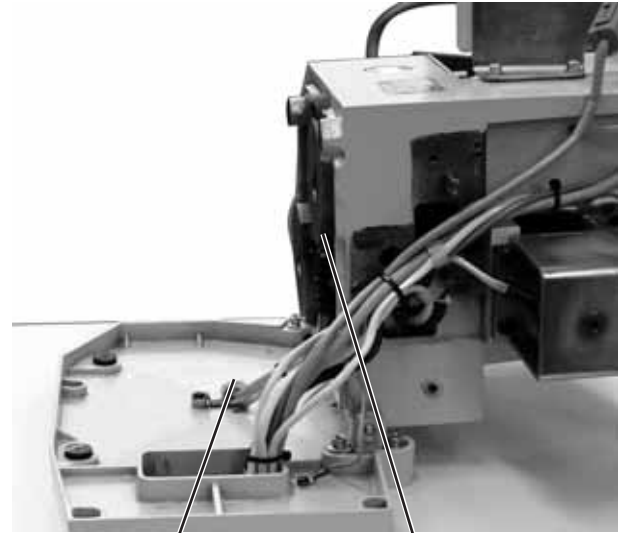

5

4



### **Caution: Danger of injury!**

Switch off main switch.

Check and adjust lubricating oil pump only when the automatic bartacker is switched off.

### **Standard checking**

The pump 3 sucks the oil contained in the oil pan 5 back into the upper oil reservoir via filter 4.

### **Correction**

- Loosen screws 2.
- Adjust angle 1 with the oil pump in the slotted holes so that the pump works.
- Tighten screws 2.

## 8. Exchange the control unit

See:

Part 2, Installing instruction: "Sewing software installation".

## 9. Maintenance



### Caution: Danger of injury !

Switch off main switch.

Maintenance work of the automatic bartacker must only be carried out when the machine is switched off.

The daily or weekly maintenance work (cleaning and oiling) to be carried out by the operators of the automatic bartacker are described in the operating instructions (chapter 10). They are only listed in the following table to complete the picture.

Maintenance work to be carried out	Operating hours			
	8	40	160	500
<b>Bartacker head</b>				
- Remove sewing dust and thread tails	X			
- Check oil level in the oil reservoirs for the lubrication of the sewing machine head	X			
<b>Control circuitry cabinet</b>				
- Remove sewing dust and thread tails	X			
- Clean fan grill	X			