

1280/5

**Engineered sewing station for
closing long seams**

Operating instructions

Installation instructions

Service instructions

1

2

3



Foreword

This instruction manual is intended to help the user to become familiar with the machine and take advantage of its application possibilities in accordance with the recommendations.

The instruction manual contains important information on how to operate the machine securely, properly and economically. Observation of the instructions eliminates danger, reduces costs for repair and down-times, and increases the reliability and life of the machine.

The instruction manual is intended to complement existing national accident prevention and environment protection regulations.

The instruction manual must always be available at the machine/sewing unit.

The instruction manual must be read and applied by any person that is authorized to work on the machine/sewing unit. This means:

- Operation, including equipping, troubleshooting during the work cycle, removing of fabric waste,
- Service (maintenance, inspection, repair and/or
- Transport.

The user also has to assure that only authorized personnel work on the machine.

The user is obliged to check the machine at least once per shift for apparent damages and to immediately report any changes (including the performance in service), which impair the safety.

The user company must ensure that the machine is only operated in perfect working order.

Never remove or disable any safety devices.

If safety devices need to be removed for equipping, repairing or maintaining, the safety devices must be remounted directly after completion of the maintenance and repair work.

Unauthorized modification of the machine rules out liability of the manufacturer for damage resulting from this.

Observe all safety and danger recommendations on the machine/unit! The yellow-and-black striped surfaces designate permanent danger areas, eg danger of squashing, cutting, shearing or collision.

Besides the recommendations in this instruction manual also observe the general safety and accident prevention regulations!

General safety instructions

The non-observance of the following safety instructions can cause bodily injuries or damages to the machine.

1. The machine must only be commissioned in full knowledge of the instruction book and operated by persons with appropriate training.
2. Before putting into service also read the safety rules and instructions of the motor supplier.
3. The machine must be used only for the purpose intended. Use of the machine without the safety devices is not permitted. Observe all the relevant safety regulations.
4. When gauge parts are exchanged (e.g. needle, presser foot, needle plate, feed dog and bobbin) when threading, when the workplace is left, and during service work, the machine must be disconnected from the mains by switching off the master switch or disconnecting the mains plug.
5. Daily servicing work must be carried out only by appropriately trained persons.
6. Repairs, conversion and special maintenance work must only be carried out by technicians or persons with appropriate training.
7. For service or repair work on pneumatic systems, disconnect the machine from the compressed air supply system (max. 7-10 bar). Before disconnecting, reduce the pressure of the maintenance unit.
Exceptions to this are only adjustments and functions checks made by appropriately trained technicians.
8. Work on the electrical equipment must be carried out only by electricians or appropriately trained persons.
9. Work on parts and systems under electric current is not permitted, except as specified in regulations DIN VDE 0105.
10. Conversion or changes to the machine must be authorized by us and made only in adherence to all safety regulations.
11. For repairs, only replacement parts approved by us must be used.
12. Commissioning of the sewing head is prohibited until such time as the entire sewing unit is found to comply with EC directives.



It is absolutely necessary to respect
the safety instructions marked by these signs.
Danger of bodily injuries !
Please note also the general safety instructions.



Preface and general safety instructions

Part 1: Operating instructions cl. 1280/5

1.	Description of product	
1.1	Description of proper use	3
1.2	Brief description	3
1.3	Technical data	4
2.	Optional equipment	
3.	Switching on - Switching off - Program stop	
3.1	Switching on	6
3.2	Switching off	6
3.3	Program stop	7
3.4	Restart after program stop	7
4.	Operation of the sewing machine head	
4.1	General notes	8
4.2	Recommended threads	9
4.3	Removing/ Putting on the fabric sliding sheet	10
5.	Operation of the engineered sewing station	
5.1	Feeding the workpieces and starting the sewing process	11
5.2	Adjusting the blowing air for the nozzles in the table top	12
5.3	Setting of needle feed, bottom feed and differential feed	13
5.3.1	Needle feed, bottom feed and differential feed of sewing stations with cylinder	13
5.3.2	Needle feed, bottom feed and differential feed of sewing stations with step motors	14
5.4	Contour guide via knee switch	14
5.5	Stacker	15
6.	Operation of the control	
6.1	Operator terminal	16
6.2	User interface	18
6.2.1	Menu structure of the sewing and setting programs	18
6.3	Seam programs	20
6.4	Setting the control	22
6.4.1	Altering seam-specific parameters	23
6.4.2	Altering global parameters	28
6.4.3	Input - Output test	29
6.4.4	Creation of seam programs	30
6.4.5	Deleting a seam program	31
6.4.6	Altering seam programs (Changing/Completing the sequence)	31

7.	Error messages	32
8.	USB stick	
8.1	General notes	33
8.2	Formatting the USB stick	33
8.3	Plugging the USB stick in the control	33
8.4	USB functions	34
8.4.1	Storing data on the USB stick.	36
8.4.2	Loading data from the USB stick	36
8.4.3	Data comparison	37
8.4.4	Deleting data from the USB stick.	37
8.4.5	Loading software version from the USB stick	38
8.5	Removing the USB stick	39
9.	Maintenance	
9.1	Cleaning and checking	40
9.2	Oil lubrication	42

1. Description of product

1.1 Description of proper use

The **1280/5** is an engineered sewing station which can properly be used for sewing light to medium-weight material. Such material is, as a rule, made of textile fibres. These materials are used in the garment industry.

In general only dry material must be sewn on this machine. The material must not contain any hard objects.

The seam is generally made with core thread, polyester fibre or cotton threads.

The dimensions for needle and hook threads can be taken from the table in chapter 4.2.

Before using any other threads it is necessary to estimate the consequential dangers and to take the respective safety measures, if required.

This sewing unit must only be installed and operated in dry and well-kept rooms. If the sewing unit is used in other rooms, which are not dry and well-kept, further measures to be agreed upon may become necessary (see EN 60204-31 : 1999).

We, as a manufacturer of industrial sewing machines, assume that at least semi-skilled operating personnel will be working on our products so that all usual operations and, where applicable, their risks are presumed to be known.

1

1.2 Brief description

The **Beisler 1280/5** is an engineered sewing station for closing long seams, as e.g.

- ✱ trousers side seams and crotch seams,
- ✱ side seams without vent in upper fabric,
- ✱ lining in skirt parts

According to the machine head it is possible to sew

- ✱ double-chainstitch seams (401),
- ✱ 4-thread safety seams (515) or 5-thread safety seams (516).

The engineered sewing station is mainly used for sportswear trousers, as e.g. cotton trousers, Chinos and US style trousers.

All sewing station components are mounted on a stand welded of square steel tubes and controlled by a microprocessor system.

The sewing station is operated via a control panel. Here it is possible to call up various control programs, to define new programs and to check all inlets and outlets for maintenance and repair purposes.

Machine head

- Pegasus overlock machine
EXT 3216-03
- Direct drive Efka Type DC 1500 /AB 221
- Microprocessor control, freely programmable
- Light barrier for recognizing the seam beginning and seam end for the automatic sewing start and stop
- Programmable edge guide for different material thicknesses

- External control panel Efka V850 with:
 - Menu navigation
 - Freely programmable parameters for “Differential bottom feed (optional)”, “Needle feed (optional)”, “Machine parameters”, “Global parameters”, “Program sequences”
 - Input and output tests
 - Check routine for step motors
 - 20 program storage locations
 - up to 7 seam programs per program storage location
- Vertical cutter with suction for overlocking and serging in one operation
- Chain separator with suction, programmable
- Adjustable blowing nozzles in the table top for supporting the material feed, mechanical regulation of the blowing intensity by an adjusting knob, duration of table blowing programmable
- Deposit table for trousers parts
- Special sewing equipment for trousers side seams with side seam pockets and wing pockets
- Height-adjustable stand, infinitely variable from 815 mm to 1200 mm
- Automatic fullness distribution by step motor-controlled needle and bottom feed (optional)
- Integrated stacking device
- Manual stacking via shortcut key
- Light-barrier for recognizing the seam beginning and seam end selectable via key

1.3 Technical data:

Machine head:	Pegasus EXT 3216-03
Stitch type:	401, 515, 516
Number of needles:	1 or 2
Needle system:	B27
Needle size:	Nm 80 to Nm 110
Hook type:	Chainstitch hook, cross-line, overlock hook
Threads:	see table chapter 4.2
Speed:	6500 r/ min
Speed upon delivery:	6500 r/ min
Stitch length: min.	0.5 mm
max.	3.5 mm
Seam width:	10 mm
Optional:	8 - 12 mm
Material:	Light to medium-weight material
Operating pressure:	6 bar
Air consumption:	20 NL per working cycle
Rated voltage:	1 x 230 V 50/60 Hz
Rated load:	0.95 kVA
Dimensions:	1800 x 1200 x 1500 mm (L x W x H)
Working height:	815...1200 mm (upper table top edge)
Weight:	115 kg

Noise level: **LC = 80dB (A)**
Workstation-specific emission value according to DIN 45635-48-B-1
Stitch length: 2.6 mm
Seam length: 1000 mm
Speed: 6500 r/min
Material: G1 DIN 23328 2 layers
Measuring point according to
DIN 4895 Part 1 X = 550 mm Y = 0 mm Z = 600 mm
x - axis = at right angles to the feeding direction
y - axis = main feeding direction
z - axis = height

2. Optional equipment

See annex

3. Switching on - Switching off - Program stop



1

3.1 Switching on

- Switch on main switch 1 (turn in clockwise direction).
The control loads the machine program.
The basic display appears in the display of the control panel.

3.2 Switching off

- Switch off main switch 1 (turn counter-clockwise).

3.3 Program stop



2

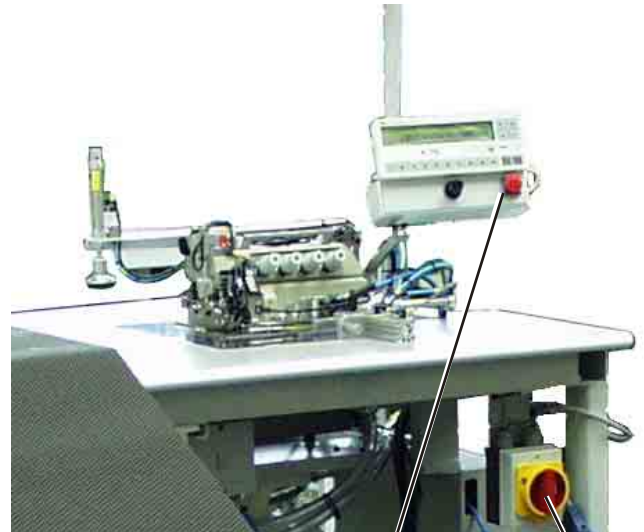

2

1

1

For an immediate stop in case of operating errors, needle breakage etc. the safety system of the engineered sewing station 1280/5 provides the following measures:

- Press program stop switch 2 at the control panel. The running operations are stopped immediately.
- Turn main switch 1 counter-clockwise. The sewing unit drops out immediately; all movements of the sewing unit stop immediately.

3.4 Restart after program stop



Caution: Risk of injury!

Switch the main switch off.
Clear the fault only with the sewing station switched off.
Only restart the sewing station after the fault has been cleared.

- Switch on main switch 1 (turn in clockwise direction).
- Unlock the program stop switch. The control loads the machine program. The basic display appears in the display of the control panel. The sewing station is ready for operation again.

4. Operation of the sewing machine head

4.1 General notes

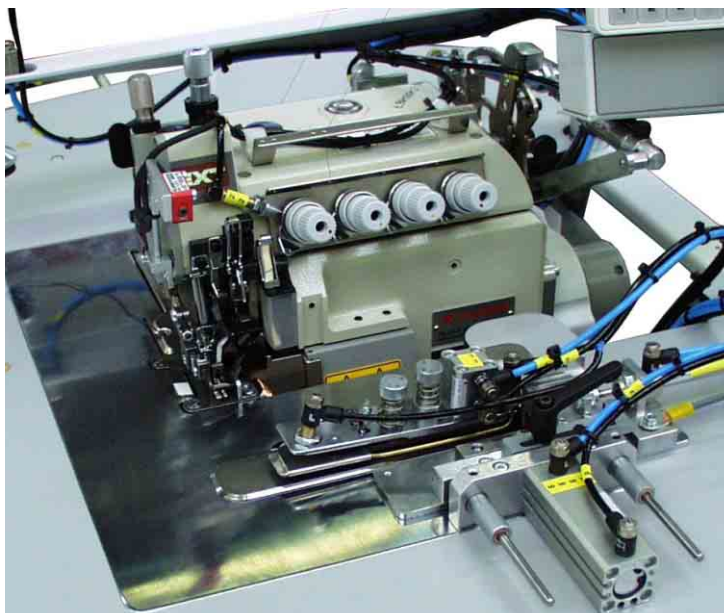

The operation of the sewing machine head (needle insertion, threading of needle thread and hook thread etc.) is described in the attached separate Pegasus operating instructions.

The instruction manual is included in the accessories of the sewing unit.



Attention: Risk of injury!

Please read the operating instructions of the sewing machine head carefully and observe all notes on safety.

4.2 Recommended threads

Needle system:	B27
Recommended needle size:	Nm 80 for very thin material Nm 90 for thin material Nm 100 for medium-weight material Nm 110 for heavy-weight material

High sewing security and good sewability are achieved with the following core threads:

- Two-ply polyester endless polyester core-spun (e.g. Epic Poly-Poly, Rasant x, Saba C, ...)
- Two-ply polyester endless cotton core-spun (e.g. Frikka, Koban, Rasant, ...)

If these threads are not available, the polyester fibre or cotton threads listed in the table can also be sewn.

Often two-ply core threads are offered by the thread manufacturers with the same designation as three-ply polyester fibre threads (3cyl.-spun). This causes uncertainty with regard to twisting and thread thickness.

When in doubt, unravel the thread and check whether it is twisted 2- or 3-ply.

The label no. 120 on the thread reel of a core thread corresponds e.g. to the thread size Nm 80/2 (see table values in brackets).

In case of monofilament threads you can use needle threads and hook threads of the same thickness. The best results are achieved with soft and elastic threads (software) of the thread thickness 130 Denier.

1

Recommended thread thicknesses:

Needle size Nm	Core thread		Core thread	
	Needle thread Polyester endless Label No.	Hook thread Polyester core-spun Label No.	Needle thread Polyester endless Label No.	Hook thread Cotton core-spun Label No.
80				
90	120 (Nm 80/2)	120 (Nm 80/2)	120 (Nm 80/2)	120 (Nm 80/2)
100 - 110	100 (Nm 65/2)	100 (Nm 65/2)	100 (Nm 65/2)	100 (Nm 65/2)
Needle size Nm	Polyester fibre thread (3cyl.-spun)		Cotton thread	
	Needle thread	Hook thread	Needle thread	Hook thread
80	Nm 120/3	Nm 120/3	Ne _B 60/3-80/3	Ne _B 60/3-80/3
90	Nm 80/3-120/3	Nm 80/3-120/3	Ne _B 50/3-70/3	Ne _B 50/3-70/3
100 - 110	Nm 70/3-100/3	Nm 70/3-100/3	Ne _B 40/3-60/3	Ne _B 40/3-60/3

4.3 Removing / Putting on the fabric sliding sheet

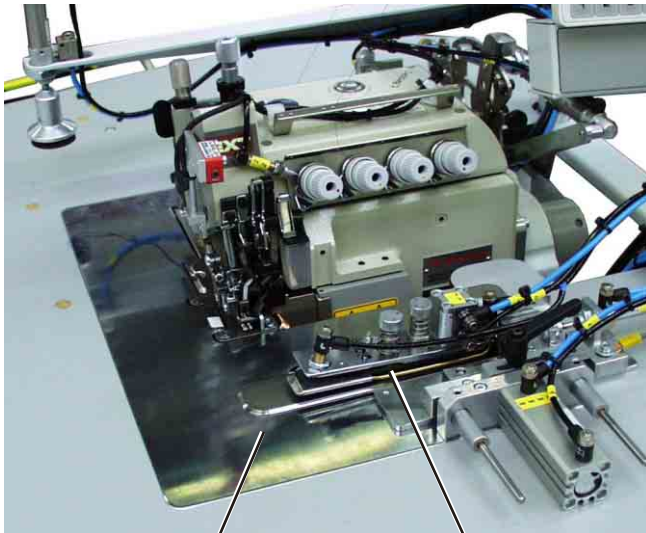

2

3



2

1

The fabric sliding sheet 2 is held in the gap of the table top by the magnets 1.
The edge guide 3 is fastened on the fabric sliding sheet.

Removing the fabric sliding sheet

- Carefully remove the edge guide 3 from the magnets in upward direction.
- Swivel the fabric sliding sheet aside.
The lower section of the sewing machine head is accessible now.

Putting on the fabric sliding sheet

- Push the fabric sliding sheet into the gap of the table top and insert in downward direction.

5. Operation of the engineered sewing station

5.1 Feeding the workpieces and starting the sewing process

The engineered sewing station 1280/5 works semi-automatically at high speed.

The operator of the sewing station has to do the following:

- ✱ call up the desired seam program;
- ✱ feed the workpiece precisely;
- ✱ start the sewing process by foot switch;
- ✱ supervise the sewing process of the unit;
- ✱ remove the finished parts from the stacker.



3 2 1



Feeding the trousers part and starting the sewing process

- 1) Select the seam program at the control panel (see chapter 6.3).
 - 2) Place the trousers parts on the preparation table and align them.
 - 3) Hold the trousers part to be processed with the left hand.
 - 4) Seize the trousers parts to be processed with the right hand in such a way that the middle finger is under the lower trousers part, the forefinger between both parts and the thumb on the upper trousers part.
 - 5) Hold the trousers parts in front of the feeding aid in such a way that the three guides of the feeding aid can move under (3), between (2) and above (1) the trousers parts.
 - 6) Actuate the foot switch.
The feeding aid moves forward and closes.
 - 7) Position the trousers parts guided by the feeding aid under the sewing foot until the feed-dogs seize them safely.
 - 8) Switch the contour guide on again in the hip bow area by stepping back on the pedal.
 - 9) Release the trousers parts shortly before the end of the sewing process.
The remaining sewing process is done automatically.
- The holding stamp is lowered to avoid that the trousers parts slide away.
 - The finished trousers parts are stacked.

5.2 Adjusting the blowing air for the nozzles in the table top

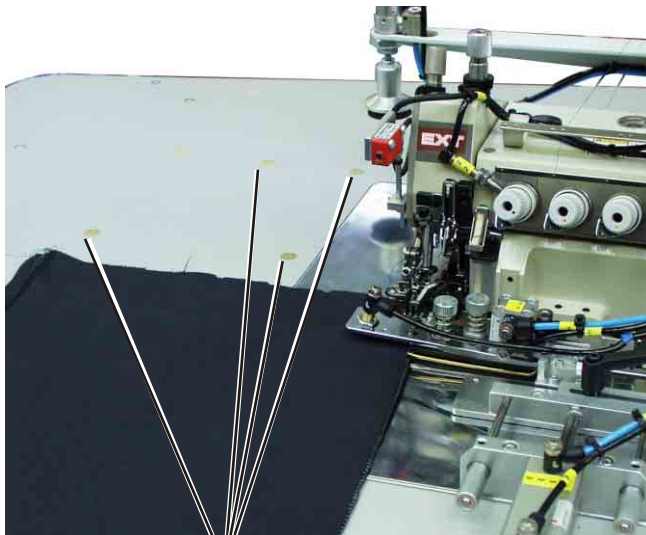

1



2

The blowing nozzles 1 in the table top support the precise stacking of the workpieces.

- Set the intensity of the air blast by dial 2 at the control panel.
Turn the dial to the right = increase the intensity of air blast
Turn the dial to the left = reduce the intensity of air blast

5.3 Setting of needle feed, bottom feed and differential feed

5.3.1 Needle feed, bottom feed and differential feed of sewing stations with cylinder



1

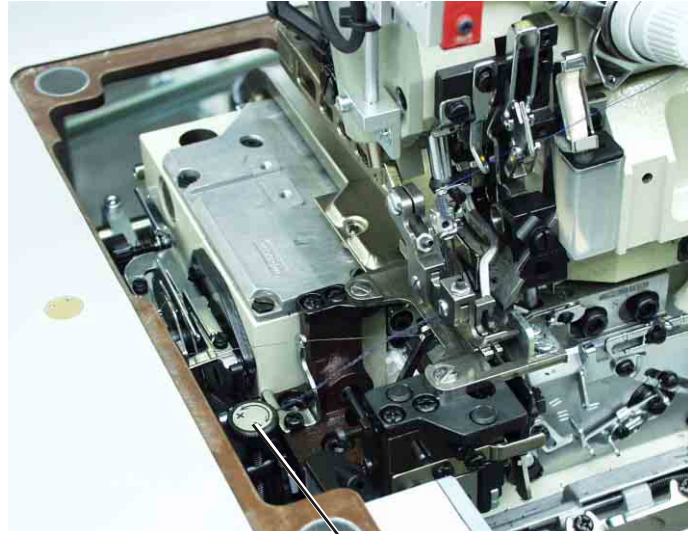

2

1

- 1 Fine adjustment of the bottom feed
- 2 Fine adjustment of the differential bottom feed
The lower fullness is switched on via the program control by means of a cylinder.
- 3 Adjusting screw for upper fullness
The upper fullness is switched on via the program control with the cylinder 6.
- 4 Stop lever for the needle feed
- 5 Fine adjustment of the needle feed



6

5

4

3

5.3.2 Needle feed, bottom feed and differential feed of sewing stations with step motors



Needle and bottom feed can be adapted to the sewing conditions via the potentiometer 1 at any time.

You can determine via the control parameters which feed is changed by the potentiometer 1.

Setting needle feed and bottom feed

- Make the corresponding settings in the control in the menu "Seam-specific parameters".
- Set the potentiometer 1 correspondingly.
Setting range: + 0 to 6 right
- 0 to 6 left

5.4 Contour guide via knee switch (optional equipment)



Via the knee switch 1 the contour guide can be retracted or extended while sewing.

- Actuate knee switch 1 while sewing.
The contour guide is retracted.
- Press knee switch 1 anew.
The contour guide is extended again.

5.5 Stacker



The finished workpieces are stacked on the throw-over stacker 2.
The stacked and clamped workpieces can be removed by actuating the foot switch 1.
The stacker is accessed by a control pulse. The pneumatic functions can be taken from the pneumatic wiring diagram.



Caution: Risk of injury!

Do not reach into the working area of the throw-over stacker during the stacking operation.

Manual stacking

- Press key 3 at the control panel.
A stacking process is carried out.

Removing stacked parts

- Actuate foot switch 1 and keep it actuated.
- Remove the stacked parts.

6. Operation of the control

6.1 Operator terminal

For the input and output of data an operator terminal with an LCD display and function keys is used.



Key	Function
1 — 0	Seam program 1 to program 20
7	Sewing stop within the seam
F1	Move the contour guide back to the basic position
F2	Manual stacking
P	Menu selection/ Store data
P 1	Needle feed, seam lines and quantities adjustable
P 2	Differential feed, seam lines and quantities adjustable
P 4	Adjust the holding stamp
P 5	Set the machine parameters
P 6	Switch the potentiometer on / off in the individual lines (optional equipment)
P 7	Adjust seam line
P 8	Input-/ Output test

Key		Function
P	9	Program the sequence (S) Creation of programs (Prg)
P	0	Set the global parameters
	E	Enter key
F1	F2	Select parameter / scroll
-	+	Alter parameter values

6.2 User interface

6.2.1 Menu structure of the sewing and setting programs

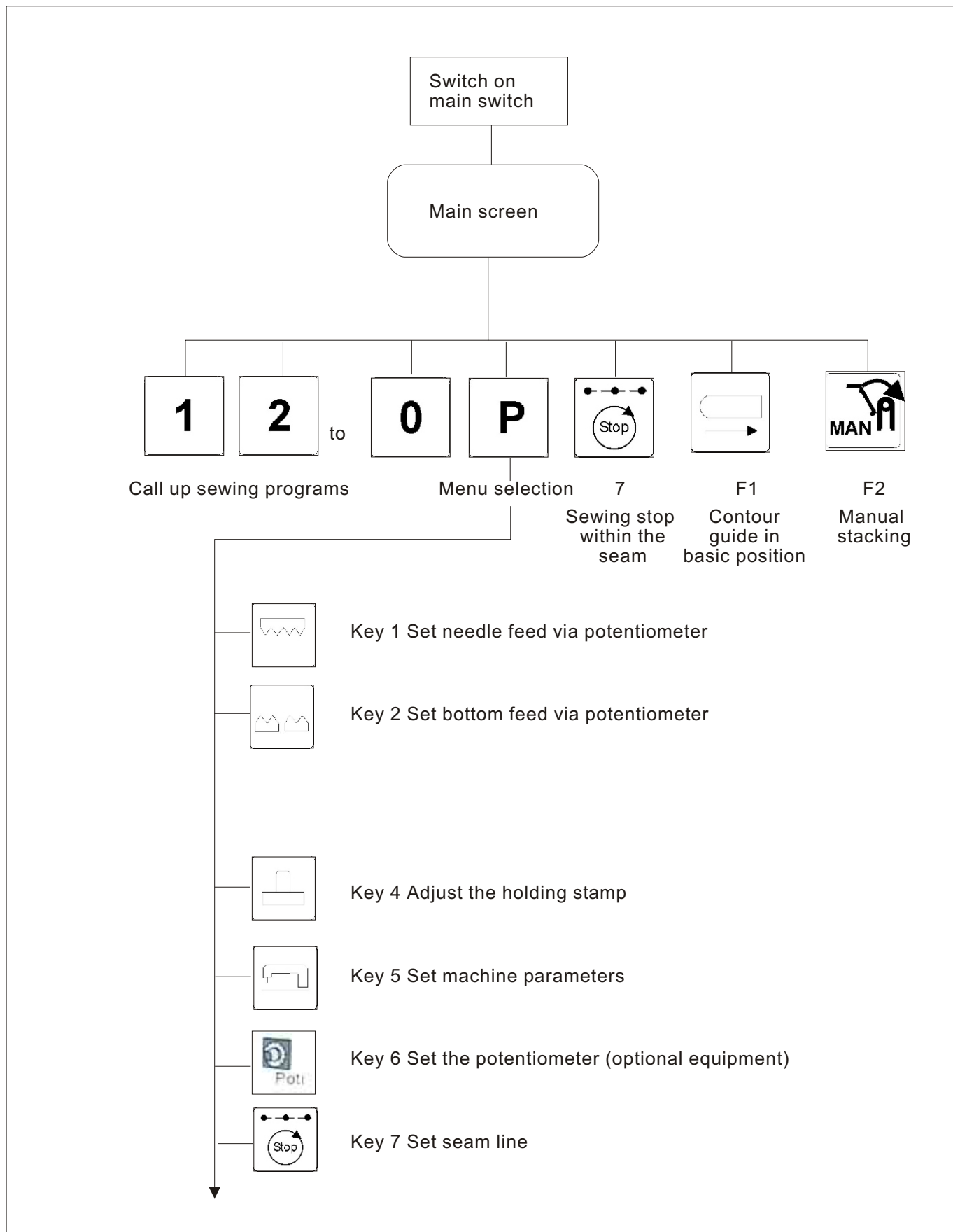

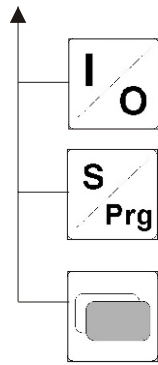

Key 8 Input- Output test

Key 9 Creation of programs / Creation of sequences

Key 0 Set global parameters

Calling up sewing programs

- Switch the main switch on.
The control initializes.
The seam program previously used is loaded.
- Press one of the keys "1, 2, 3, 4, 5, 6, 7, 8, 9, 0".
The selected seam program is loaded.

1

Calling up the parameter menu

- Switch the main switch on.
The control initializes.
The previously used program appears in the display.
- Press key "P".
The selection menu is called up.
- Press one of the keys "1, 2, 3, 4, 5, 6, 7, 8, 9, 0".
The display changes over to the corresponding function.

Contour guide forward / backward

When the seam program is selected:

- Press key "F1".
The contour guide moves forward.
- Press key "F1" anew.
The contour guide moves backward again.

Manual stacking

When the seam program is selected:

- Press key "F2".
The stacker makes a stacking movement.

6.3 Seam programs

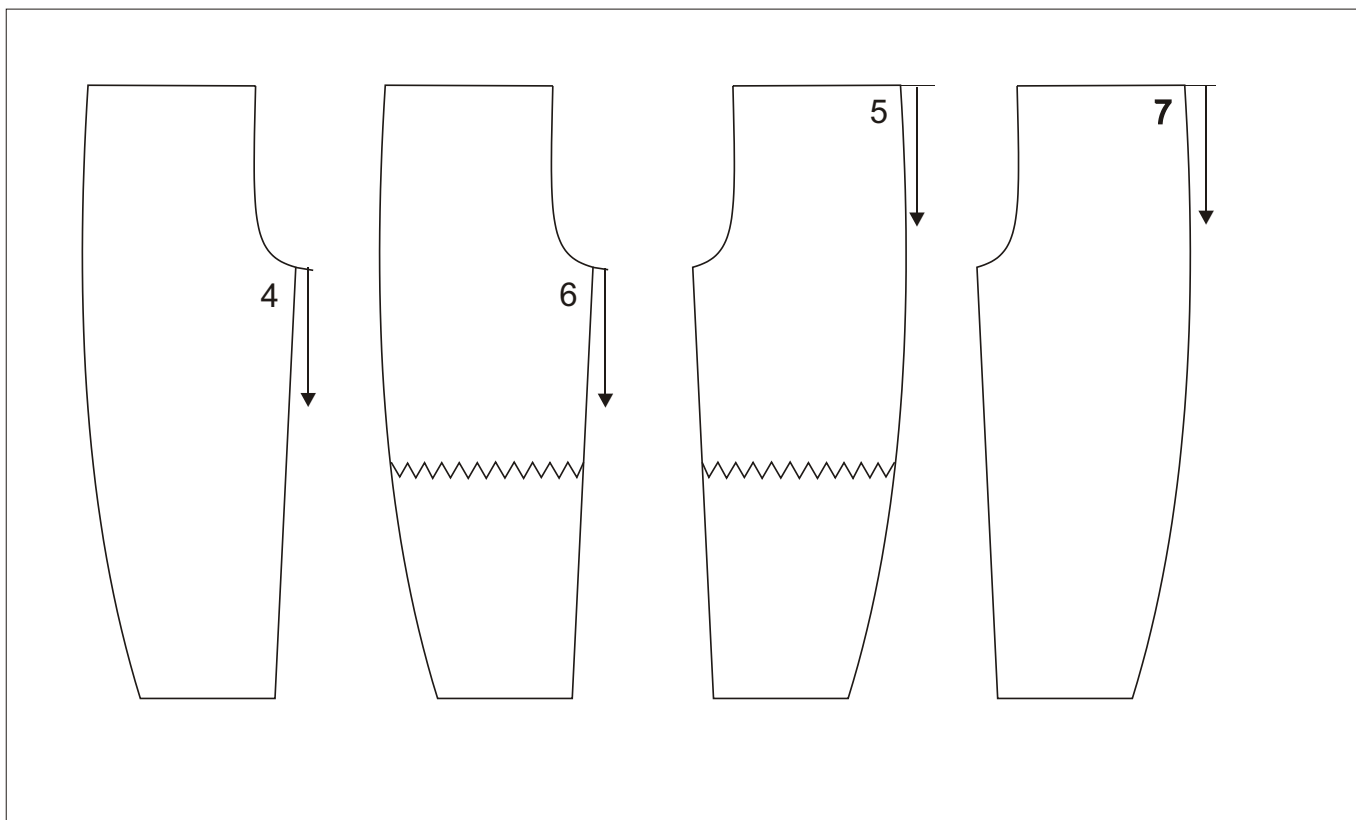

Designation of the individual seams:

4 = Crotch seam of hind trousers on top/ lining down

6 = Crotch seam of hind trousers down/ lining on top

5 = Side seam of hind trousers down/ lining on top

7 = Side seam of hind trousers on top/ lining down

A seam program in the display of the control panel



Program No.

Seam No.

The engineered sewing station 1280/5 is delivered with 9 standard seam programs:

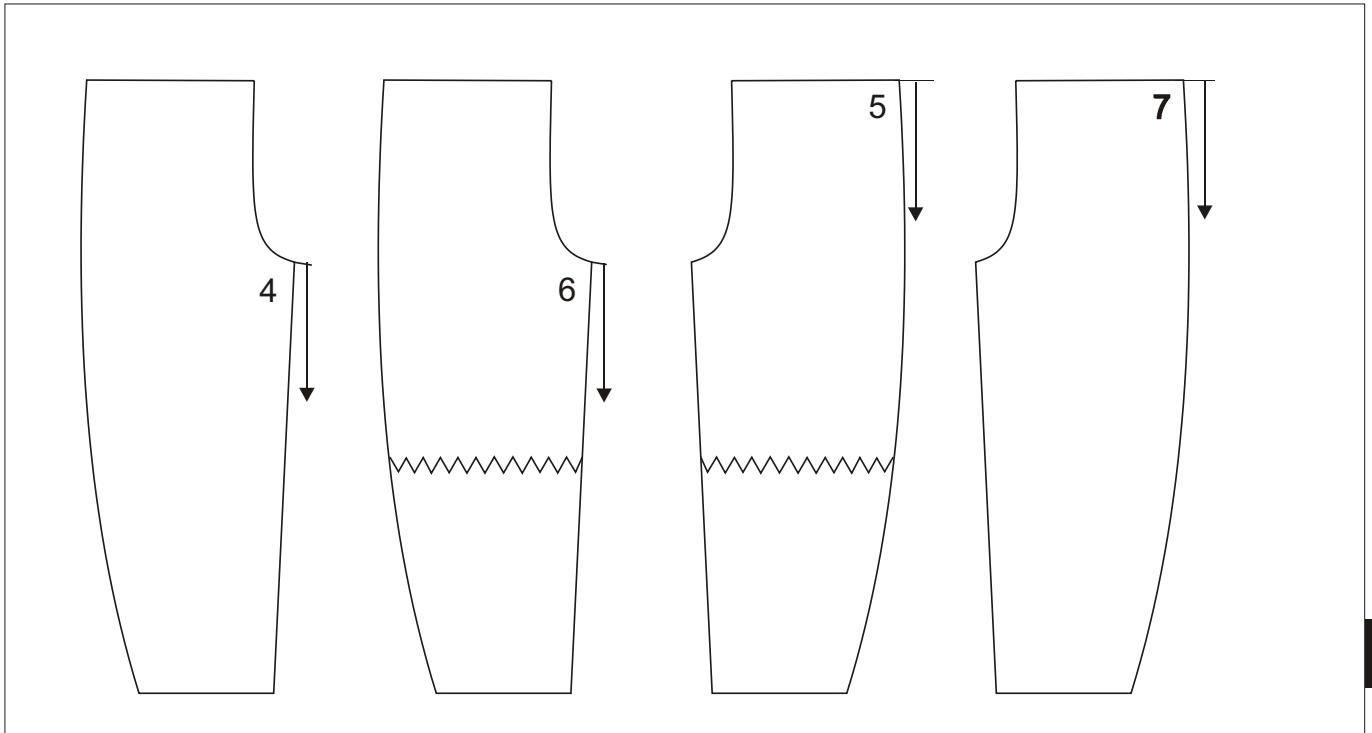

1

Program No.	Seam No.	Operation	Position of trousers	Notes
1	4	Close crotch seam	Hind trousers on top Lining down	Automatical sewing with contour guide
2	6	Close crotch seam	Hind trousers down Lining on top	Automatical sewing with contour guide
3	4 6	Close crotch seam Close crotch seam		Alternate sewing
4	7	Close side seam	Hind trousers on top Lining down	Manual sewing and guiding in the hip bow area afterwards automatical sewing
5	5	Close side seam	Hind trousers down Lining on top	Close side seam Manual sewing and guiding afterwards automatical sewing
6	7 5	Close side seam Close side seam		Alternate sewing
7	5	Close side seam	Hind trousers down Lining on top	Automatical sewing with contour guide
8	7	Close side seam	Hind trousers on top Lining down	Automatical sewing with contour guide
9	5 7	Close side seam Close side seam		Alternate sewing

6.4 Adjusting the control

The parameter values are altered in the individual parameter menus.

- Press key "P".
- Select the menu item.
- Select the parameter to be altered with the keys "F1" or "F2".
- Press key "E".
- Alter the parameter value with the keys "Plus" or "Minus".
- Press key "P".
The new parameter value is stored.
- Press key "P".
You return to the selection menu.
- Press key "P".
You return to the sewing program.

Fullness distribution with needle and bottom feed

According to the equipment of the sewing station the parameters for the needle and bottom feed are occupied differently.

The sketches below show the individual lines.

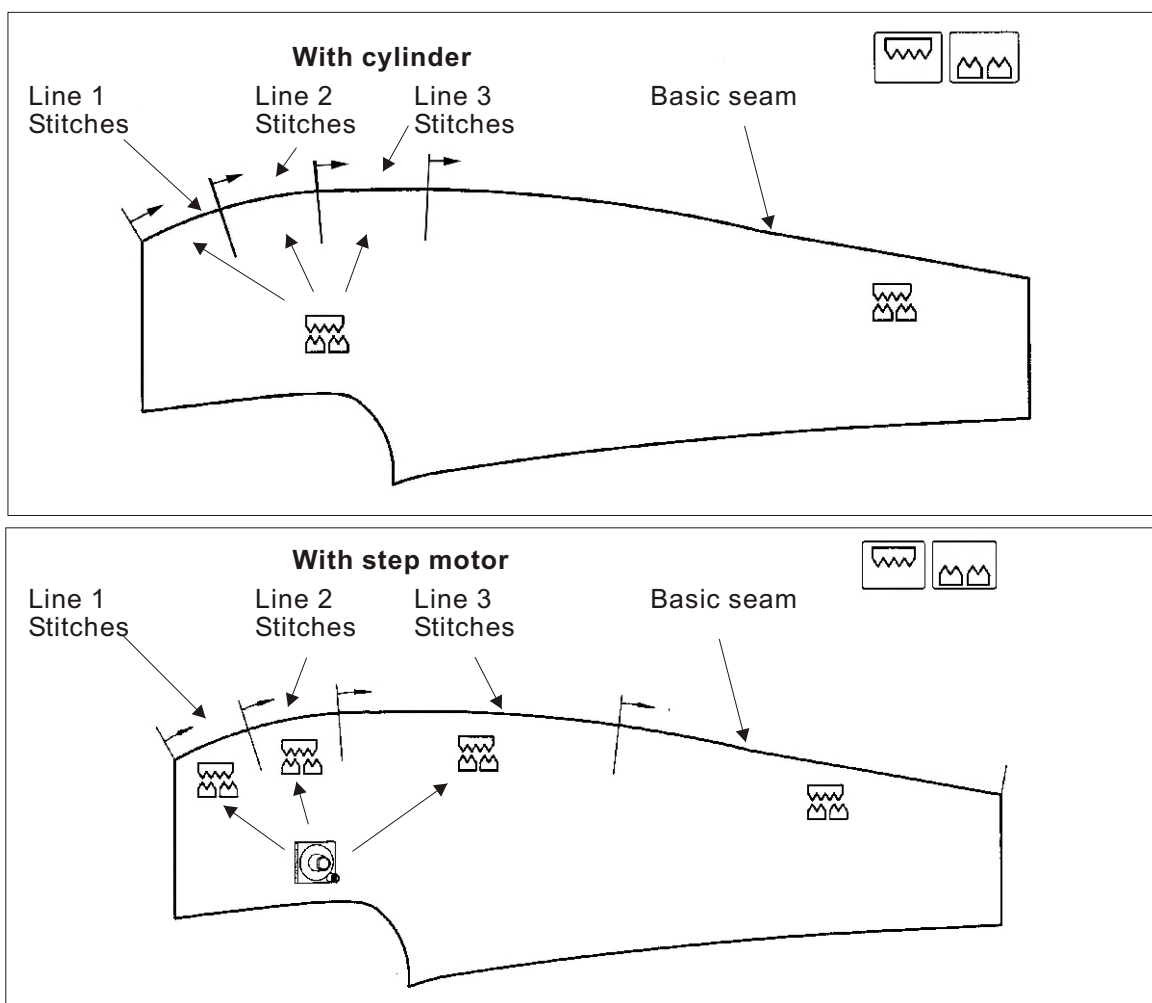

6.4.1 Altering seam-specific parameters

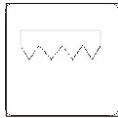

Needle feed (with cylinder)

Via this parameter the needle feed is set.

Parameter 01:	Line 1
	Number of stitches until the needle feed engages
Setting range:	0 - 2000
Parameter 02:	Fullness line 1 ON/ OFF
Setting range:	0 / 1
Parameter 03:	Line 2
	Number of stitches how long the needle feed is engaged
Setting range:	0 - 2000
Parameter 04:	Fullness line 2 ON/ OFF
Setting range:	0/1
Parameter 05:	Line 3
	Number of stitches how long the needle feed is engaged
Setting range:	0 - 2000
Parameter 06:	Fullness line 3 ON/ OFF
Setting range:	0/1

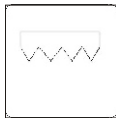

Needle feed (with step motor)

Via this parameter the needle feed with step motor drive is set.

Parameter 01:	Line 1
	Number of stitches
Setting range:	0 - 2000
Parameter 02:	Fullness in line 1
Setting range:	0 - 2000
Parameter 03:	Line 2
	Number of stitches
Setting range:	0 - 2000
Parameter 04:	Fullness in line 2
Setting range:	0 - 2000
Parameter 05:	Line 3
	Number of stitches
Setting range:	0 - 2000
Parameter 06:	Fullness in line 3
Setting range:	0 - 2000

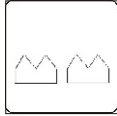

Bottom feed (with cylinder)

Via this parameter the differential feed is set.

- Parameter 07: Line 1
Number of stitches until the differential bottom feed engages
Setting range: 0 - 2000
- Parameter 08: Fullness line 1 ON/ OFF
Setting range: 0 / 1
- Parameter 09: Line 2
Number of stitches how long the differential bottom feed is engaged
Setting range: 0 - 2000
- Parameter 10: Fullness line 2 ON/ OFF
Setting range: 0 / 1
- Parameter 11: Line 3
Number of stitches how long the differential bottom feed is engaged
Setting range: 0 - 2000
- Parameter 12: Fullness line 2 ON/ OFF
Setting range: 0 / 1

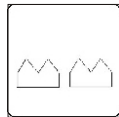

Bottom feed (with step motor)

Via this parameter the differential feed with step motor drive is set.

- Parameter 07: Line 1
Number of stitches
Setting range: 0 - 2000
- Parameter 08: Fullness in line 1
Setting range: 0 - 2000
- Parameter 09: Line 2
Number of stitches
Setting range: 0 - 2000
- Parameter 10: Fullness in line 2
Setting range: 0 - 2000
- Parameter 11: Line 3
Number of stitches
Setting range: 0 - 2000
- Parameter 12: Fullness in line 3
Setting range: 0 - 2000

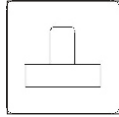

Adjusting the holding stamp

Via this parameter the holding stamp is set.

Parameter 15: Number of stitches when the stamp lowers
Setting range: 0 ...20 stitches

Parameter 16: Number of stitches how long the warp separator remains switched on
Setting range: 0 ...100 stitches

Parameter 17: Switch the stacker on or off
Setting range: 0 / 1

Parameter 47: Time of the stacker movement
Input: 0 ...2000

Parameter 57: Time how long the holding stamp is down
Input: 0...2000

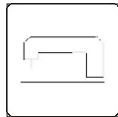

Altering the machine parameters

Parameter 30: Set the main speed
Setting range: 0 - 6500

Parameter 31: Manual sewing on/ off
Setting range: 0 / 1

Parameter 32: Number of stitches how long the table blowing remains switched on
Setting range: 0 ...400 stitches

Parameter 33: Number of stitches until the contour guide lowers
Setting range: 0 ...400 stitches (?)

Parameter 34: Number of stitches until the contour guide lowers
Setting range: 0 ...400 stitches

Parameter 35: Number of stitches until the contour guide retracts laterally
Setting range: 0 ...400 stitches

Parameter 37: Start mode contour modulation
1 = front, left
2 = rear, right
3 = rear, left
Setting range: Modes 1, 2, 3

Parameter 60: Soft start speed
Setting range: 500 ...5000

Parameter 61: Switch the soft start on or off
Setting range: 0 / 1

Parameter 76: Switch the start on or off via light barrier
Setting range: 0 / 1

Parameter 77: Switch the autostart on or off
Setting range: 0 / 1

Parameter 78: Number of stitches until the autostart starts
Setting range: 0 ...400 stitches



Altering the potentiometer

Parameter 18: Needle feed potentiometer Off / On
Setting range: 0 / 1

Parameter 19: Differential feed potentiometer Off / On
Setting range: 0 / 1

Parameter 24: Line 1,
Needle feed potentiometer Off / On
Setting range: 0 / 1

Parameter 25: Line 2,
Needle feed potentiometer Off / On
Setting range: 0 / 1

Parameter 28: Line 2,
Needle feed potentiometer Off / On
Setting range: 0 / 1

Parameter 96: Line 1,
Differential feed potentiometer Off / On
Setting range: 0 / 1

Parameter 97: Line 2,
Differential feed potentiometer Off / On
Setting range: 0 / 1

Parameter 99: Line 3,
Differential feed potentiometer Off / On
Setting range: 0 / 1

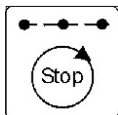

Setting the seam line

Parameter 81:	Length of line 1
Setting range:	0 ...
Parameter 82:	Line 1 Reduced speed Off / On
Setting range:	0 / 1
Parameter 83:	Line 1 Reduced speed
Setting range:	500...6500
Parameter 84:	Line 1 Stop at the end of the line Off / On
Setting range:	0 / 1
Parameter 85:	Line 1 Sewing foot lift at the end of the line Off / On
Setting range:	0 / 1
Parameter 86:	Length of line 2
Setting range:	0 ...
Parameter 87:	Line 2 Reduced speed Off / On
Setting range:	0 / 1
Parameter 88:	Line 2 Reduced speed
Setting range:	500...6500
Parameter 89:	Line 2 Stop at the end of the line Off / On
Setting range:	0 / 1
Parameter 91:	Length of line 3
Setting range:	0 ...
Parameter 92:	Line 3 Reduced speed Off / On
Setting range:	0 / 1
Parameter 93:	Line 3 Reduced speed
Setting range:	500...6500
Parameter 94:	Line 3 Stop at the end of the line Off / On
Setting range:	0 / 1

6.4.2 Altering global parameters

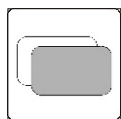

Parameter 29:	Needle feed Maximum run
Input:	0 ...120
Parameter 38:	Start delay light barrier
Input:	0 ...2000
Parameter 39:	Differential feed Maximum run
Input:	0 ...120
Parameter 40:	Basic value needle feed
Input:	0 ...120
Parameter 41:	Basic value needle feed on / off
Input:	0 / 1
Parameter 42:	Basic value differential bottom feed
Input:	0 ...120
Parameter 43:	Basic value differential bottom feed on/ off
Input:	0 / 1
Parameter 45:	Number of stitches until the table blowing is switched on
Input:	0 ...400
Parameter 46:	Duration of the stacker impulse
Input:	0 ...2000
Parameter 47:	Time of the stacker movement
Input:	0 ...2000
Parameter 48:	Speed limitation
Input:	max. 6500
Parameter 49:	Speed during the warp separation
Input:	500...5000
Parameter 50:	Number of stitches until the thread tension is opened (seam end)
Input:	0...50
Parameter 56:	Seam programming on/ off On = 1 Determine the seam sequences in the current program Off = 0 Create the next free program with seams
Input:	0 / 1
Parameter 58:	Display of the software version
Parameter 59:	Number of stitches how long the seam chain is sucked (seam beginning)
Input:	0 ...50
Parameter 65:	Thread tension lift
Input:	0 ...50
Parameter 79:	Soft start after "Stop in the seam"
Input:	0 ...500
Parameter 80:	Reset daily piece counter

6.4.3 Input - Output test

Via the input - output test the different input and output elements can be checked.

Input test

- Press key "P".
- Press key "8".
- Actuate the corresponding input.
Example:
Cover the light barrier.
- Press key "Program stop".
The program is quitted.

Input elements	
Switch	Designation
01	Light barrier 01
04	Knee switch
05	Switch "Program stop"
11	Potentiometer differential bottom and needle feed (optional equipment)

1

Output test

- Press key "P".
- Press key "8".
- Press key "Plus".
- Select the output element to be tested with the keys "Plus" or "Minus".
- Switch the output on or off with the key "F2".
- Press key "Program stop".
The program is quitted.

Output elements	
Switch	Designation
Y01	Sewing foot up
Y02	Thread tension lift open
Y03	Contour guide up / down
Y04	Stacker on
Y05	Holding stamp up / down
Y07	Contour guide forward / backward
Y08	Contour guide blowing on
Y09	Move contour guide laterally
Y10	Differential bottom feed on / off
Y11	Needle feed on / off
Y12	Warp separator off / on
Y13	Table blowing off / on
Y14	Dirt suction off / on

6.4.4 Creation of seam programs

Note

Before a new seam program can be created or an existing one can be deleted, the global parameter "56" has to be set to the value "0". This avoids that the existing programs are changed inadvertently.

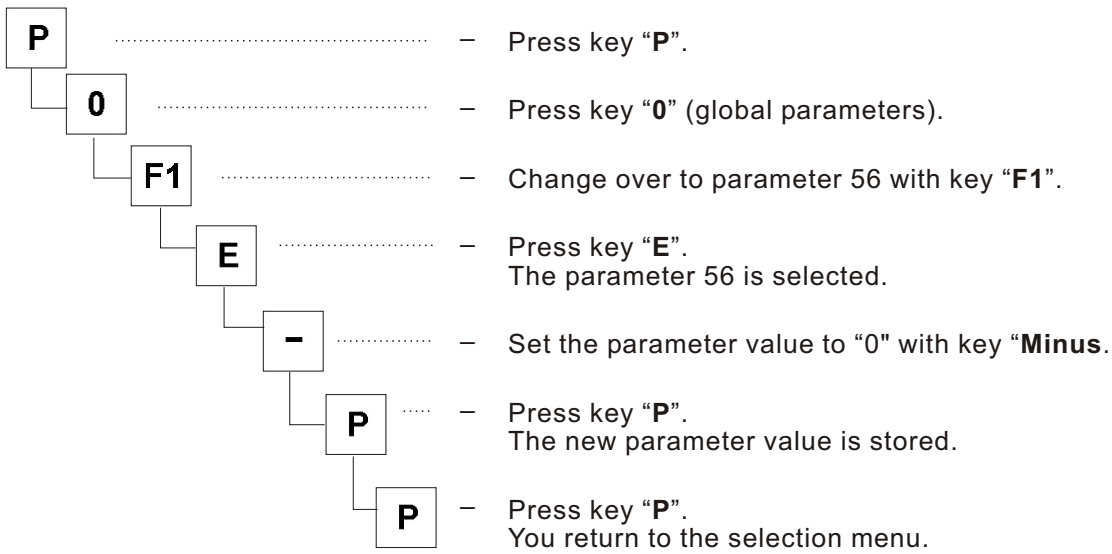

Creating a seam program

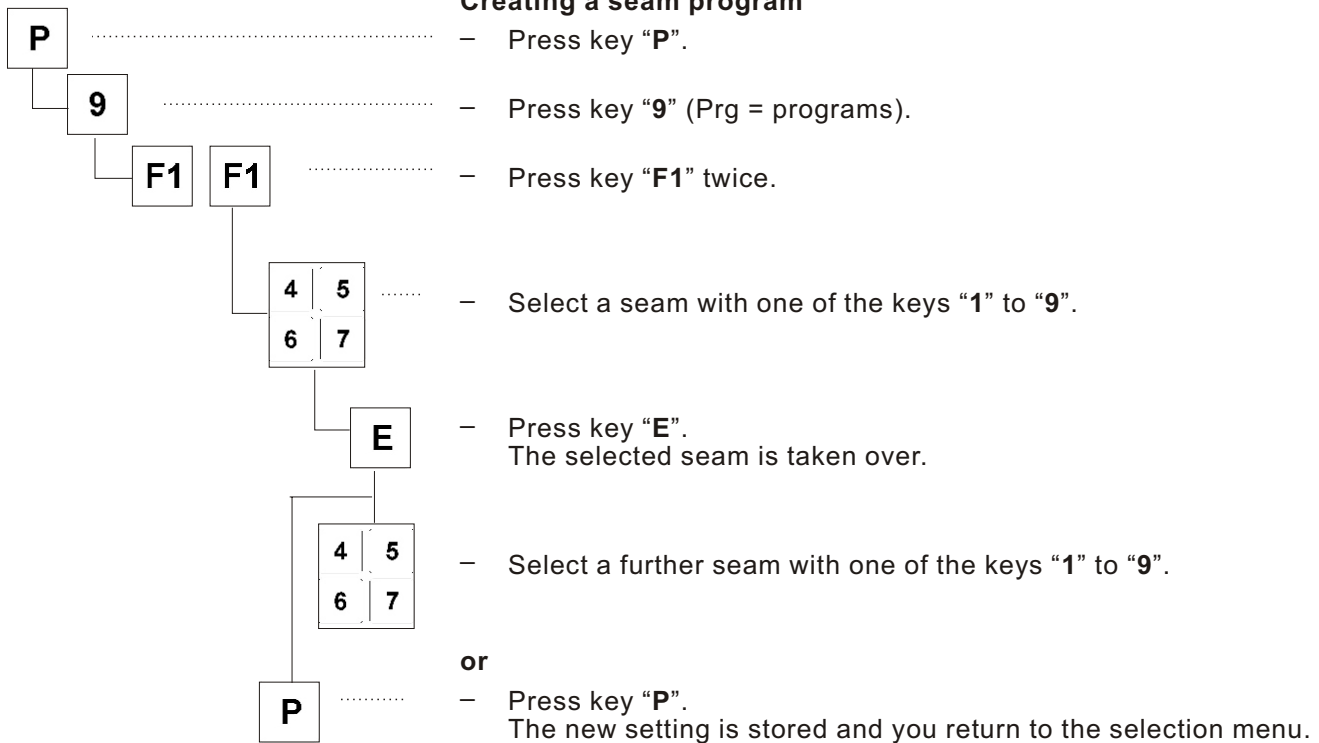

Note

After the creation of a new seam program the parameter "56" has to be reset to the value "1" for safety reasons.

6.4.5 Deleting a seam program

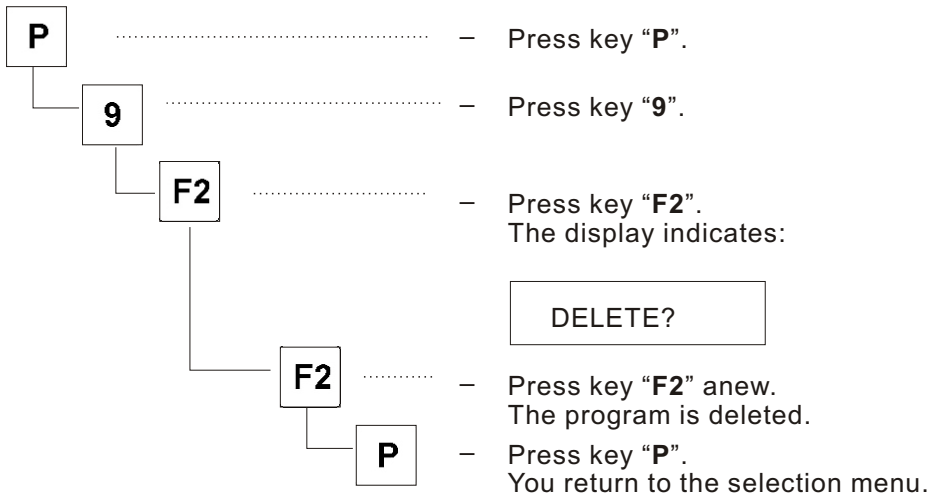

6.4.6 Altering seam programs (Changing / Completing the sequence)

1

Note

Before a seam program can be altered, the parameter "56" has to be set to the value "1". This avoids that the existing programs are deleted inadvertently. (see chapter 6.4.3, paragraph 1)

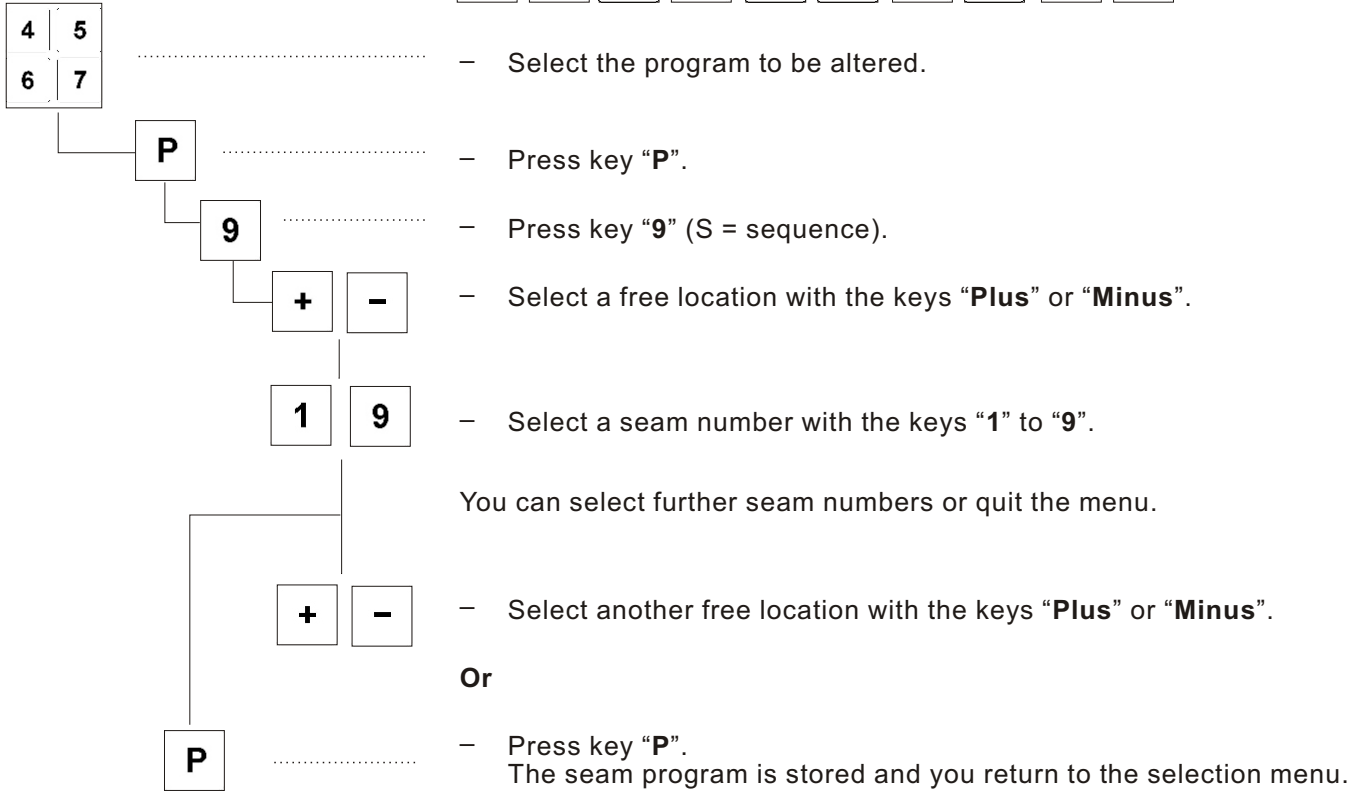

7. Error messages

In case of an error in the control system or in the machine program corresponding error messages are indicated in the display.

Display	Meaning
Error 1	One of the parameters "18" or "19" is switched on (value = 1)
Error 2	Both parameters "18" and "19" are switched on (value = 1)
Error 3	In the current program the last existing seam was to be deleted.

Errors of free programming

Info U1	FP custom code wrong, e.g. describing a parameter which does not exist.
Info U2	Wrong system function
Info U3	Wrong in / out number
Info U4	Too many user variables
Info U5	Too many system variables
Info U6	Not enough storage location for the user program
Info U7	Wrong or undefined key in the Vario
Info U8	Unknown device address
Info U9	Fatal exception error

Errors and informations bootloader

Info B1	Switch on control in the boot mode and press key "F2"
Info B2	Programming of segment number
Info B3	Flash programming failed
Info B4	Flash programming okay

8. USB stick

8.1 General notes



The USB stick 1 serves for storing and transferring of the sewing unit software.

By means of the USB stick program and parameter data can also be transferred to other sewing units.

Commercially available USB 1 sticks can be used, too.

1

8.2 Formatting the USB stick

Before using a new USB stick this has to be formatted correspondingly. The file format is the “**FAT 16**” system.

- Format the USB stick with the FAT 16 system via a PC.

8.3 Plugging the USB stick in the control

- Switch the main switch off.
 - Plug the USB stick 1 in the lower slot of the Efka control.
 - Press key “**P**” and keep it pressed.
- P**
- Switch the main switch on.
The message appears for a moment.
- P**
- USB. DEV. DETECT:
- Keep key “**P**” pressed until the following message appears in the display:
- SERVICE - CODE
- 3** **1** **1** **2**
- Enter CODE 3112.
- E**
- Press key “**E**”.

8.4 USB functions

The following functions can be carried out with a USB stick:

1) Storing and loading of global parameters

File extension = *.PAR

Parameter	Function
F-510	Securing from the control on the USB stick
F-511	Loading from the USB stick in the control
F-512	Comparing USB stick and control data
F-513	Deleting data from the USB stick

2) Storing and loading of programs and seam parameters

File extension = *.PAY

Parameter	Function
F-514	Securing from the control on the USB stick
F-515	Loading from the USB stick in the control
F-516	Comparing USB stick and control data
F-517	Deleting data from the USB stick

3) Loading a new software version

File extension = *.PRG

Parameter	Function
F-523	Load a new software version from the USB stick in the control

By means of the FAT 16 file system the control allocates file names with max. 8 characters.

Max. 8 characters

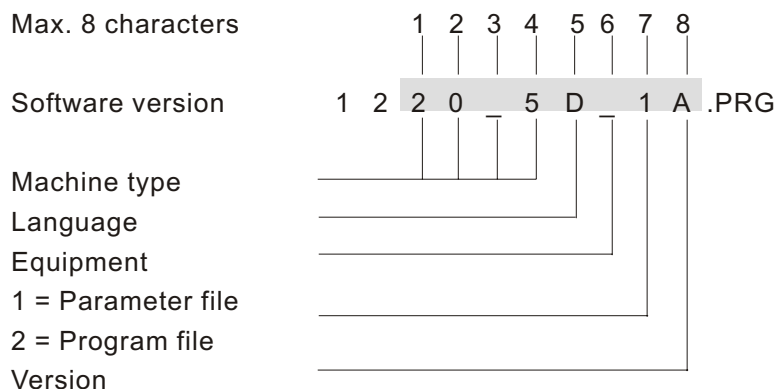

If different program or parameter files are stored, the control allocates a new name each.

Example:

Storing of different parameter data

1st file 0100DATA.PAR

2nd file 0101DATA.PAR

etc.

The files can individually be renamed by the file manager or explorer on a PC.

Note

On principle, the Efka control can read data from the main level of the USB stick only. Data from subdirectories cannot be processed.

8.4.1 Storing data on the USB stick

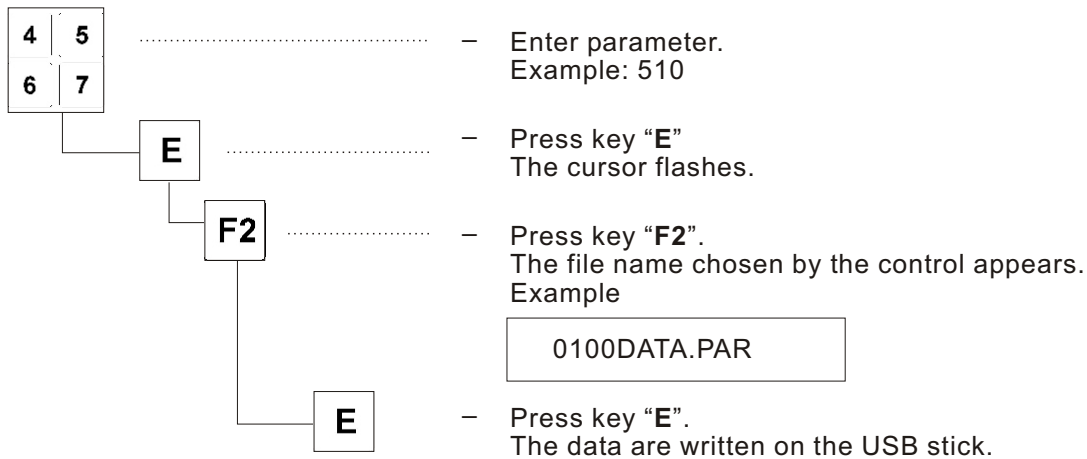

Note

The file name is allocated automatically.

8.4.2 Loading data from the USB stick

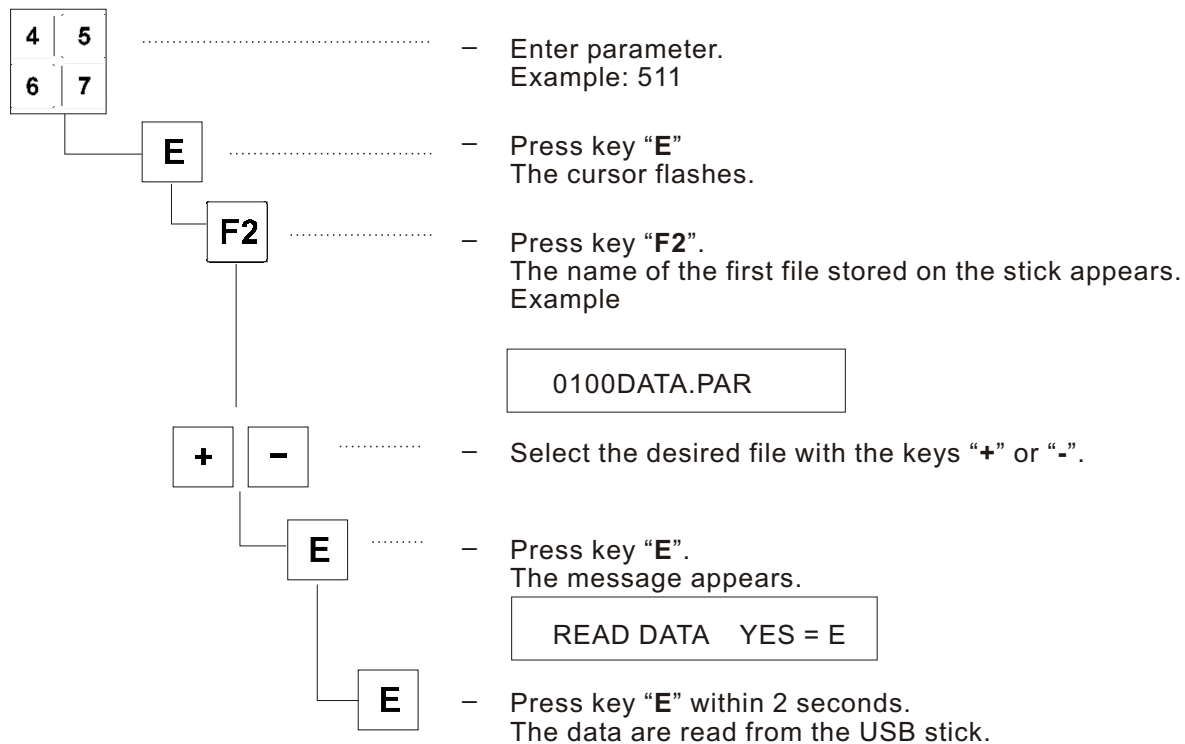

8.4.3 Data comparison

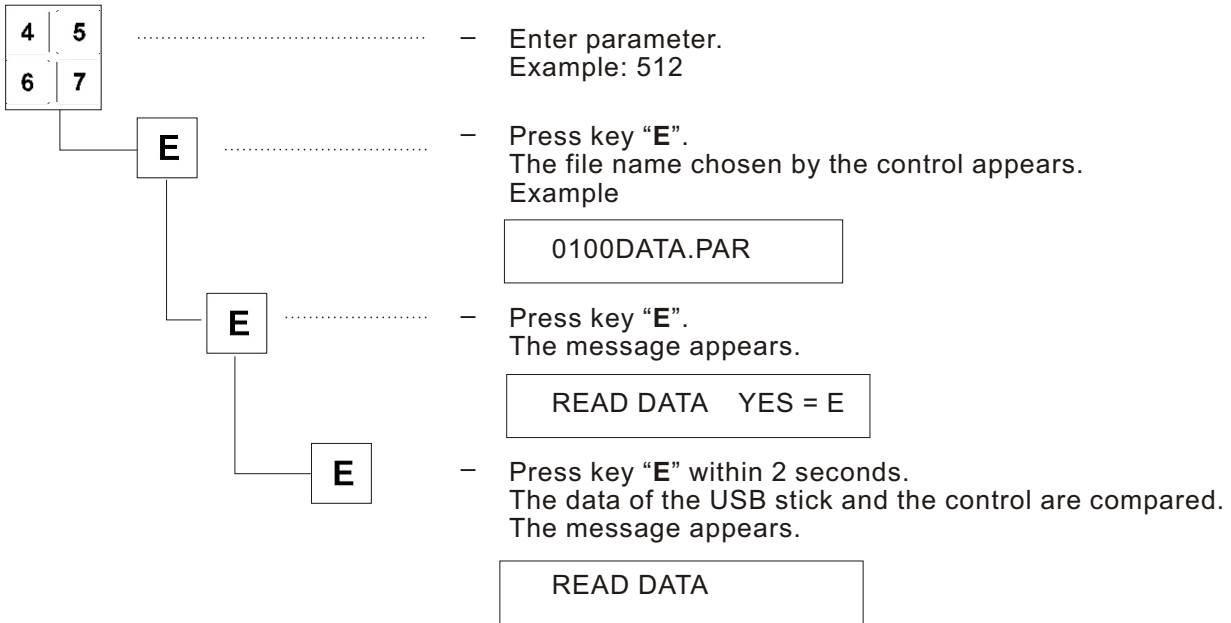

Possible displays

DATA OK	The data on the stick are identical with the data of the control
DATA DIFFERENT	The data of the stick and the control are not identical.

8.4.4 Deleting data from the USB stick

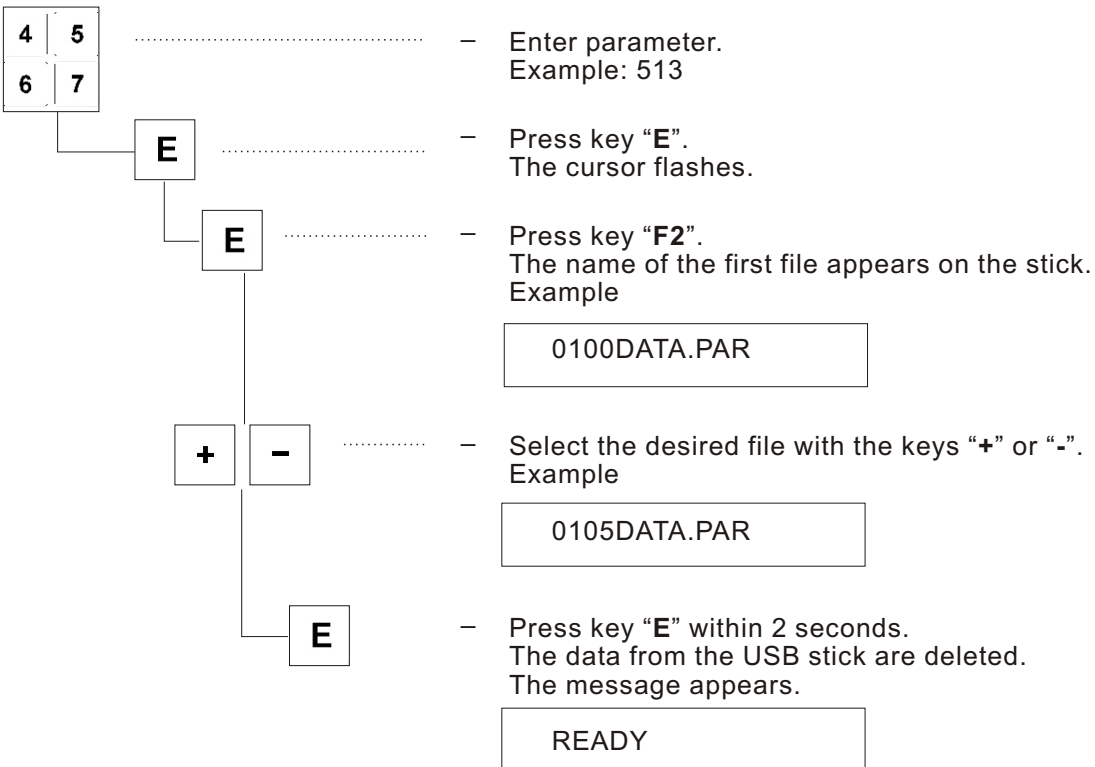

8.4.5 Loading software version from the USB stick

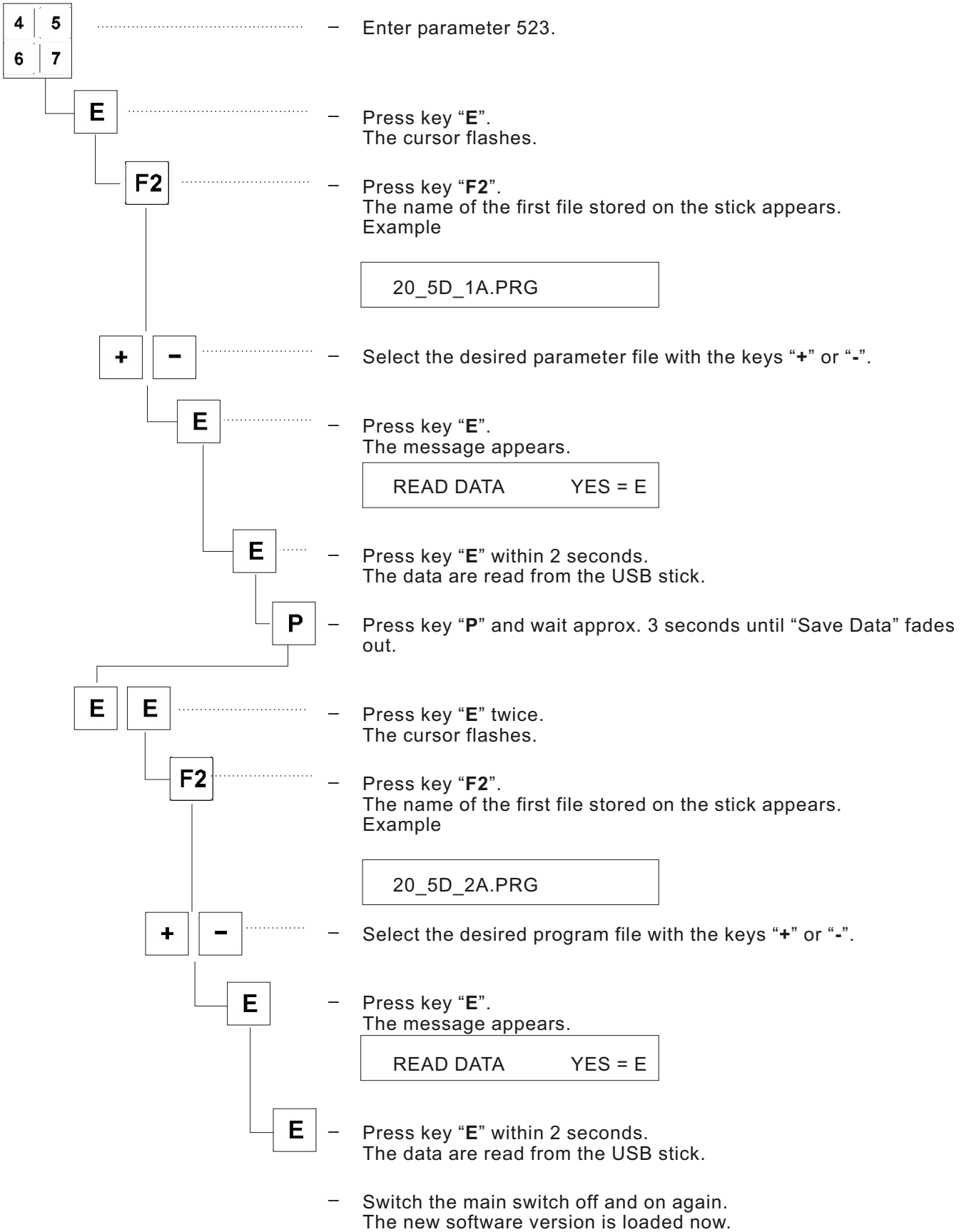

8.5 Removing the USB stick



- Switch the main switch off.
- Pull the USB stick 1 out of the slot of the Efka control.

1

9. Maintenance

9.1 Cleaning and checking



Caution: Risk of injury !

Switch the main switch off.

The maintenance of the engineered sewing station must only be carried out with the machine switched off.

Maintenance work has to be done after the intervals indicated in the tables at the latest (see column "Operating hours").

The processing of fluffy material may require shorter maintenance intervals.

A clean sewing station protects from disturbances.

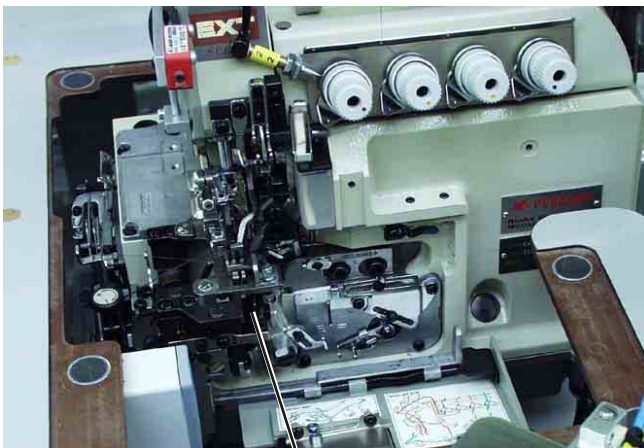

1

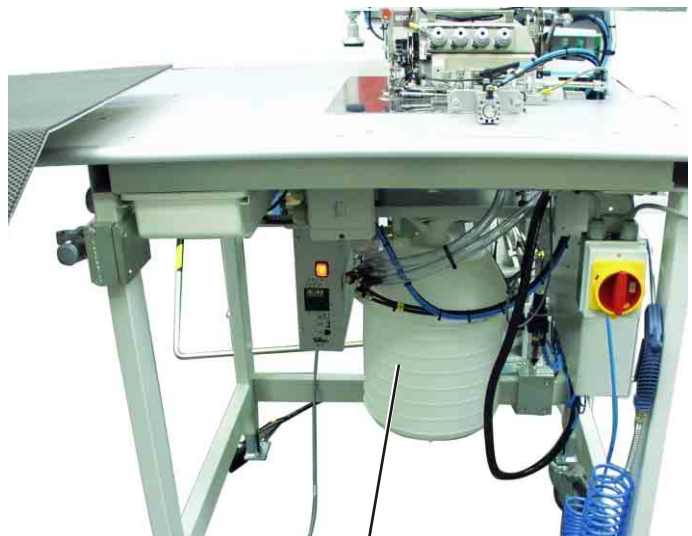

2



6

5

4

3

Maintenance work to be done	Explanation	Operating hours
Machine head		
- Remove sewing dust and thread remainders. (e.g. with compressed air pistol)	Clean the entire area 1 of the thread guides under the fabric sliding sheet	8
Suction device		
	Empty container 2 of the suction device - Turn the bottom part of the container to the left and remove it - Empty the container - Screw the bottom part on again in clockwise direction	8
Pneumatic system		
- Check the water level in the pressure regulator 3	The water level must not rise up to the filter insert 4. - Let the water run out of the water separator under pressure after pressing the drain plug 5.	40
- Clean the filter insert 4	The filter insert 4 separates dirt and condensed water. - Separate the sewing unit from the compressed air net. - Push in drain plug 5. The pneumatic system of the sewing unit has to be pressureless. - Screw the water separator 6 off - Remove filter insert 4. Wash the dirty filter tray and the filter insert with benzine (no solvent!) and blow them clean. - Reassemble the water separator and connect the maintenance unit.	500
- Make leak test of the system		500

9.2 Oil lubrication

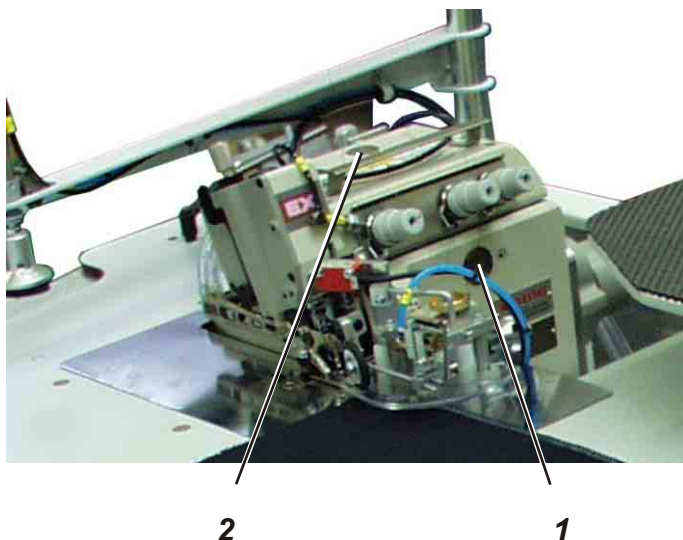

Caution: Risk of injury !

Oil may cause skin eruption.
Avoid a longer contact with the skin.
Wash yourself thoroughly after a contact.



ATTENTION !

The handling and disposal of mineral oils is subject to legal regulations.
Deliver used oil to an authorized collecting station.
Conserve your environment.
Be careful not to spill any oil.

Oil the head of the sewing unit exclusively with lubricating oil **DA-10** or an equivalent oil with the following specification:

- Viscosity at 40° C: 10 mm²/s
- Ignition point: 150° C

DA-10 can be bought at the sales points of **DÜRKOPP ADLER AG** under the following parts numbers:

Container 250 ml:	9047 000011
Container 1 litre:	9047 000012
Container 2 litres:	9047 000013
Container 5 litres:	9047 000014

Maintenance work to be done	Explanation	Operating hours
Lubrication	<p>Check the oil level at the sewing machine head regularly (inspection glass 1 and 2).</p> <p>Please take further details from the enclosed operating instructions of the sewing machine head.</p>	8

Part 2: Assembly instructions cl. 1280/5

1.	Scope of delivery	3
2.	General notes	3
3.	Installing the sewing unit	4
3.1	Transport protections	4
3.2	Setting the working height	4
3.3	Mounting the thread reel holder.	5
3.4	Aligning the material rest.	5
4.	Electrical connection	
4.1	Checking the nominal voltage	6
4.2	Making the mains connection	6
5.	Pneumatic connection	7
6.	Putting into operation	
6.1	Sewing test	8

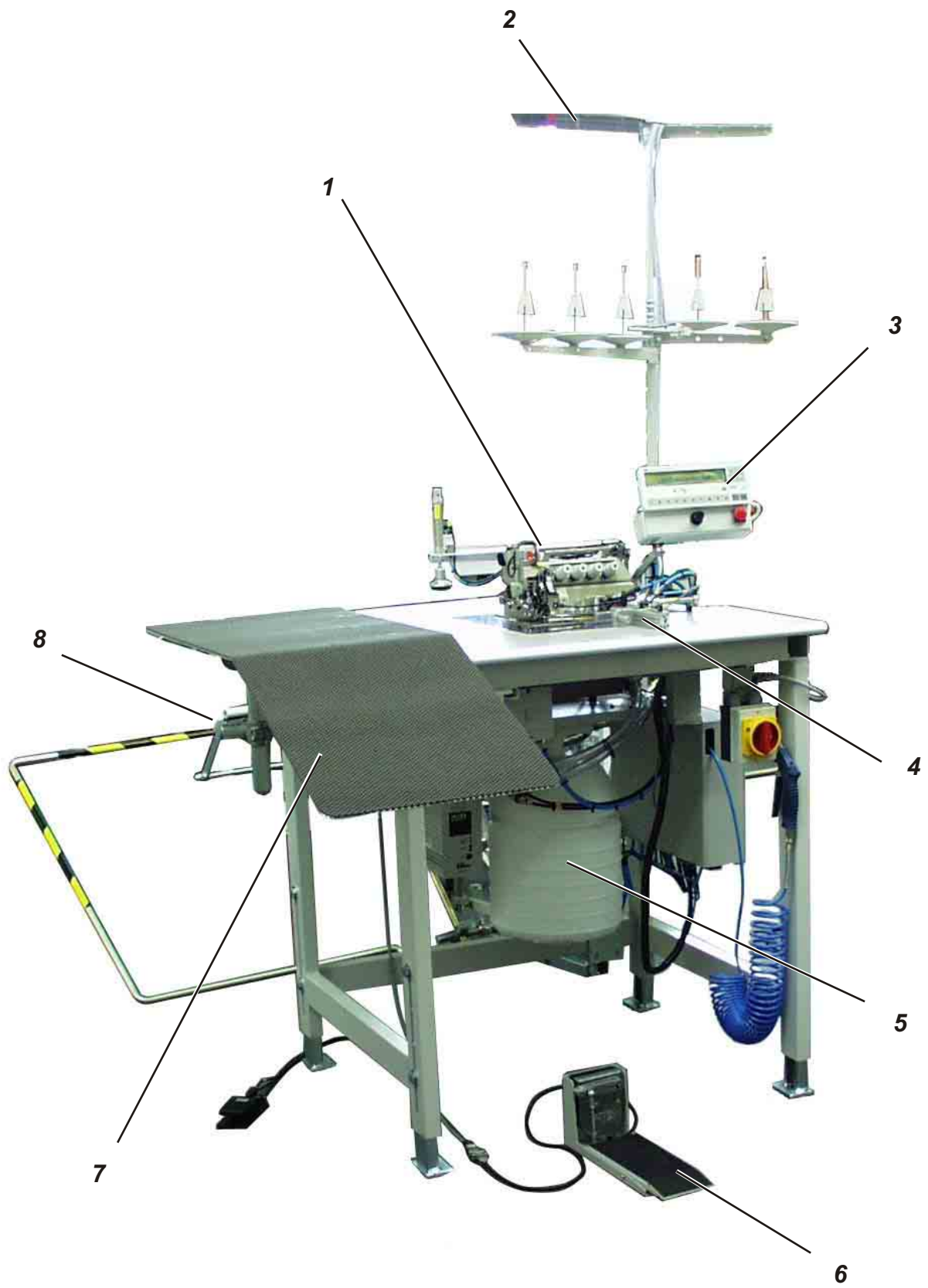

1. Scope of delivery

The scope of delivery **depends on your order**.
The sewing unit consists of:

- 1 Sewing machine head (as per order)
- 2 Thread reel holder
- 3 Control with control panel
- 4 Stand and table top
- 5 Suction unit with suction container
- 6 Foot pedal
- 7 Material rest
- 8 Stacker
- Compressed air maintenance unit with compressed air pistol

2

2. General notes



ATTENTION !

The sewing unit must only be installed by trained specialist staff.

Any work on the electrical equipment of the sewing unit must only be carried out by electricians or correspondingly instructed persons. The mains plug must be pulled out.

The enclosed operating instructions of the drive motor manufacturer have to be observed.

3. Installing the sewing unit

3.1 Transport protections

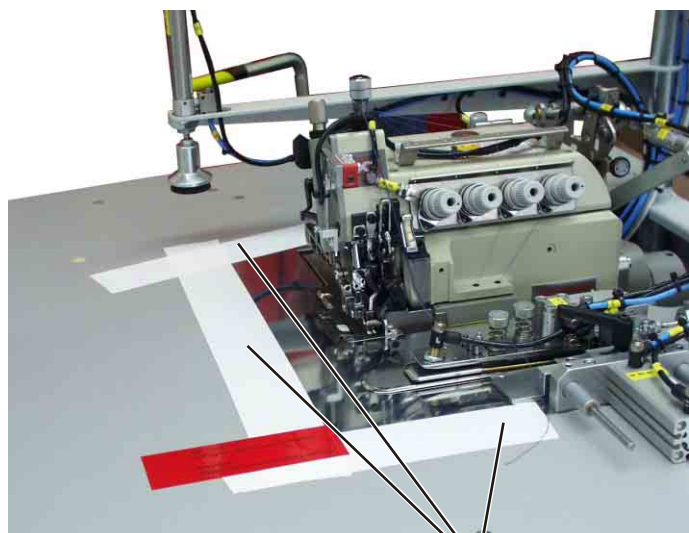

1



2

Before the installation of the sewing unit all transport protections have to be removed.

- Remove the security tapes at the thread reel holder, machine table etc.
- Remove the protective foils 1.
- Remove the security tapes from the stacker.

3.2 Setting the working height



3

4

The working height is adjustable between 815 and 1200 mm (measured up to the top edge of the table top).

- Loosen screws 3 and 4 at the spars.
- Set the desired working height with the help of suitable auxiliary means.
In order to avoid jamming lift the table top equally on both sides.
- Retighten screws 3 and 4 at the spars.

3.3 Mounting the thread reel holder

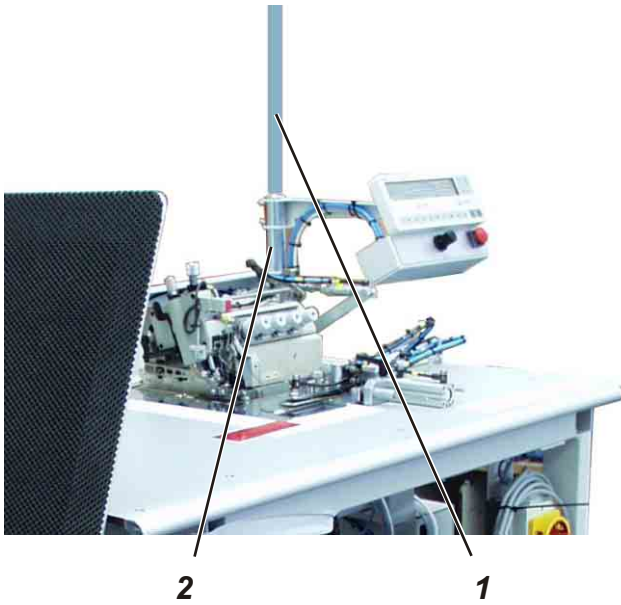

- Insert thread reel holder 1 in retainer 2.
- Tighten the thread reel holder with the two screws 3.

2

3.4 Aligning the material rest

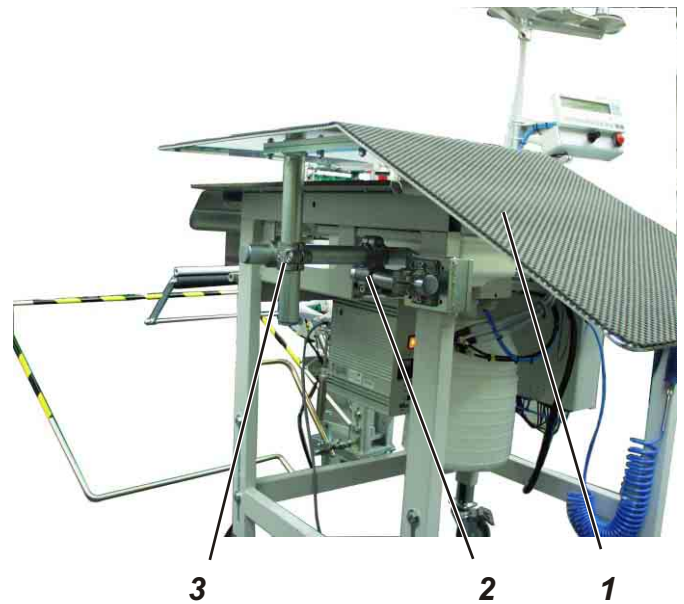

The material rest 1 has been flapped down for transportation.

- Loosen the screws at the fixtures 2 and 3.
- Swivel the material rest upwards and align it.
- Retighten the screws at the fixtures 2 and 3.

4. Electrical connection



ATTENTION !

Any work on the electrical equipment of the sewing unit must only be carried out by electricians or correspondingly instructed persons. The mains plug must be pulled out.

4.1 Checking the nominal voltage



ATTENTION !

The nominal voltage indicated on the type plate of the sewing machine control and the mains voltage must correspond.

Nominal voltage = 190 - 240 V, 50/60 Hz

4.2 Making the mains connection

- Connect the mains plug.

5. Pneumatic connection

For the operation of the pneumatic components the sewing unit has to be provided with anhydrous compressed air.



ATTENTION!

For a trouble-free function of the pneumatic control processes the compressed air net has to be rated as follows:

Even in the moment of maximum air consumption the minimum operating pressure must not drop below **6 bar**.

In case of a too high air pressure decrease:

- Increase the compressor output.
- Increase the diameter of the compressed air supply line.

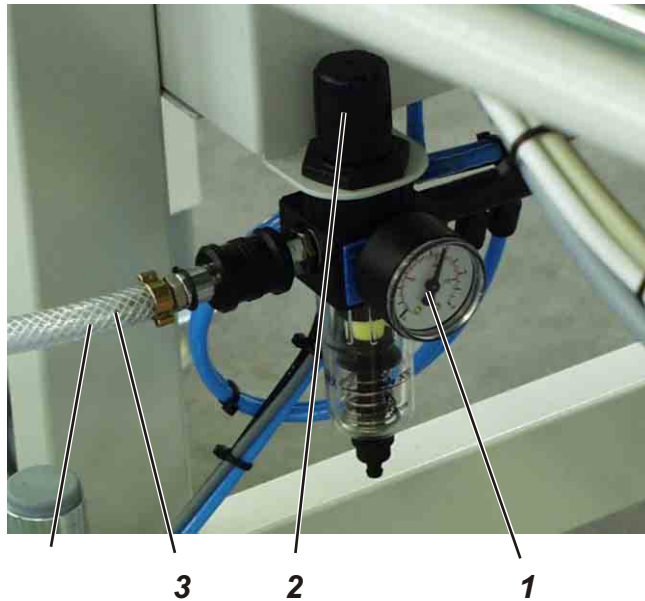

2

Connecting the compressed air maintenance unit

- Connect the connecting hose 3 to the compressed air net.

Setting the operating pressure

- The operating pressure amounts to 6 bar. It can be read off at the manometer 1.
- For setting the operating pressure pull up and turn the rotary handle 2.
 - Turn in clockwise direction = increase the pressure
 - Turn counter-clockwise = reduce the pressure



ATTENTION !

No oil-bearing compressed air must be fed from the compressed air net.

Behind the filter cleaned compressed air is withdrawn as blowing air for cleaning machine parts and for blowing workpieces out.

Oil particles contained in the blowing air lead to malfunction and stains on the workpieces.

6. Putting into operation

6.1 Sewing test

After completion of the installation work a sewing test should be made.

- Plug in the mains plug.



Caution: Risk of injury!

Switch the main switch off.

Thread in needle and hook thread only with the sewing unit switched off.

- Thread in needle and hook thread
(see operating instructions of the sewing machine head).
- Switch the main switch on.
The control is initialized.
- Select the sewing program.
- For feeding and operating see part 1:
Operating instructions 1280/5

Part 3: Service instructions class 1280/5

1. General notes	3
2. Brief instructions for the sewing head	
2.1 Adjusting the height of the needle bar	4
2.2 Adjusting the hook	5
2.2.1 Distance between left hook and needle.	5
2.2.2 Distance between right hook and needle.	7
2.3 Adjusting the needle protection	9
2.3.1 Hind needle protection.	9
2.3.2 Front needle protection	10
2.4 Adjusting the feed-dog.	11
2.4.1 Feed-dog position	11
2.4.2 Feed-dog height	12
2.5 Presser foot Head EXT3216	13
2.5.1 Presser foot	14
2.6 Upper and lower knife	15
2.6.1 Changing and adjusting the upper knife	15
2.6.2 Changing and adjusting the lower knife	16
2.7 Thread regulation of overlock hook	17
3. Adjusting the engineered sewing station	
3.1 Adjusting the light barrier	18
3.2 Adjusting the material stop	19
3.3 Adjusting the contour guide.	20
3.4 Direct sewing drive	21
3.4.1 Setting the reference.	21
4. Oil lubrication	
4.1 Oil change and oil filter change	22
5. Maintenance	23

1. General notes

The service instructions on hand describe the adjustment of the single-head overlock unit 1280/5.

The manual consists of:

- Brief instructions for the sewing head
- Service instructions for the sewing unit



ATTENTION !

The brief instructions are a summary of the detailed operating instructions of the sewing head. In any case these operating instructions have to be carefully read and all regulations have to be observed. The Beisler company does not guarantee the accuracy of the following specifications.



ATTENTION !

The operations described in the service instructions must only be executed by qualified staff or correspondingly instructed persons respectively!



Caution: Risk of injury !

In case of repair, alteration or maintenance work switch the main switch off.

Carry out adjusting operations and functional tests of the running machine only under observation of all safety measures and with utmost caution.

The instruction manual on hand describes the adjustment of the engineered sewing station in an appropriate sequence.

Please observe in this connection that various setting positions are interdependent.

Therefore it is absolutely necessary to do the adjustment following the described order.

For all setting operations of parts involved in the stitch formation a new needle without damage has to be inserted.

2. Brief instructions for the sewing head

2.1 Adjusting the height of the needle bar

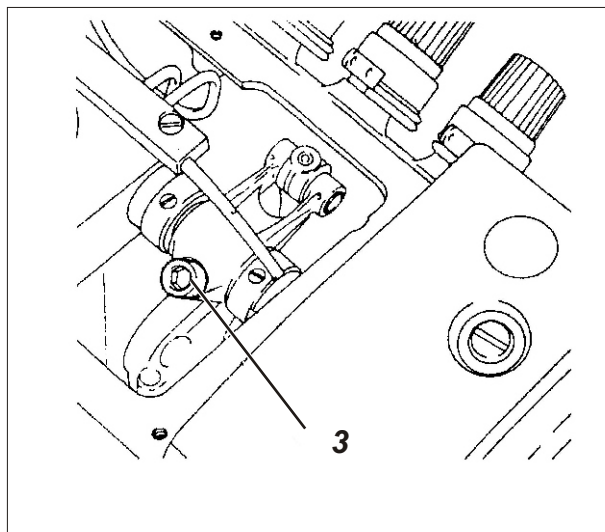
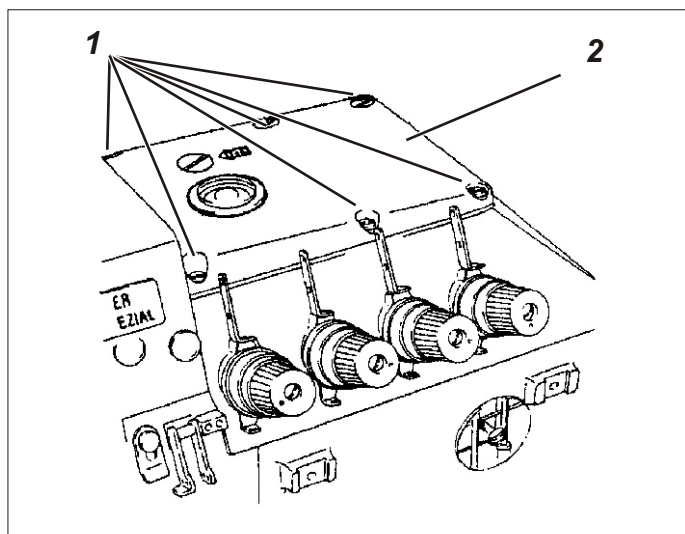

Caution: Risk of injury!

Switch the main switch off.

Check and adjust the height of the needle bar only with the sewing station switched off.

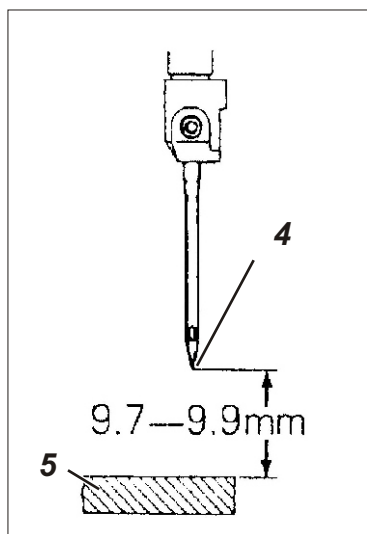

Standard checking

In the top dead centre of the needle bar the distance between the needlepoint 4 and the throat plate should amount to 9.7 - 9.9 mm.

- Move the needle bar in its top dead centre.
- Check whether the distance between needlepoint 4 and throat plate 5 amounts to 9.7 - 9.9 mm.

Correction

- Unscrew screws 1 and remove cover 2.
- Move the needle bar in its top dead centre.
- Swivel the sewing foot out.
- Loosen screw 3 until the needle bar can just be pushed.
- Shift the needle bar in such a way that the distance between needlepoint 4 and throat plate amounts to 9.7 - 9.9 mm.
- Tighten screw 3.
- Screw cover 2 on again.

2.2 Adjusting the hook

2.2.1 Distance between left hook and needle

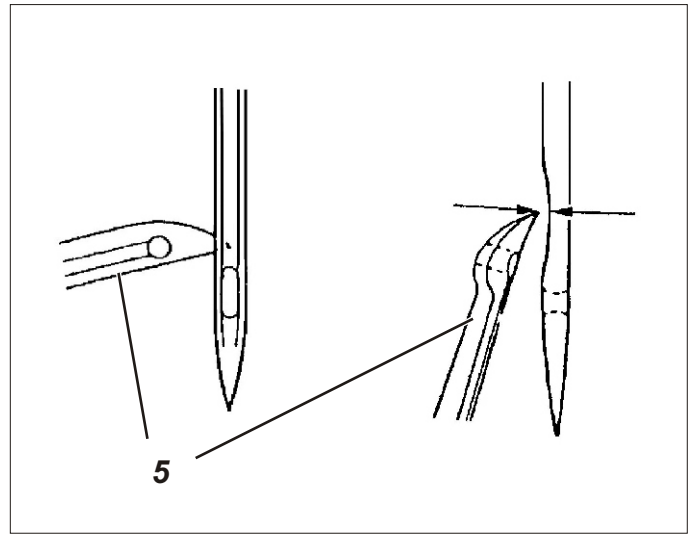
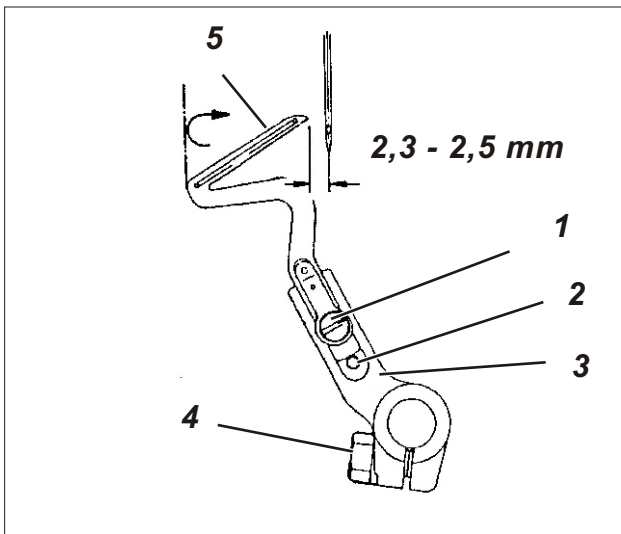

Caution: Risk of injury!

Switch the main switch off.

Check and adjust the hook only with the sewing station switched off.

3

Cross-line adjustment

Standard checking

In the left reverse point of hook 5 the distance between the middle of the needle and the hook tip should amount to 2.3 - 2.5 mm.

- Move the **left** hook in its **left** reverse point by handwheel.
- Check whether the distance between the middle of the needle and the hook tip amounts to 2.3 - 2.5 mm.

Correction

- Unscrew the throat plate, the front feed-dog as well as the front and hind needle protection.
- Move the hook in its left reverse point by handwheel.
- Loosen screw 1 and take care that the hook abuts on stop 2.
- Tighten screw 1 again.
- Loosen screw 4 until the hook support 3 can just be turned.
- Turn the hook support in such a way that the distance between the middle of the needle and the hook tip amounts to 2.3 - 2.5 mm.

Note

Do not yet tighten screw 4.

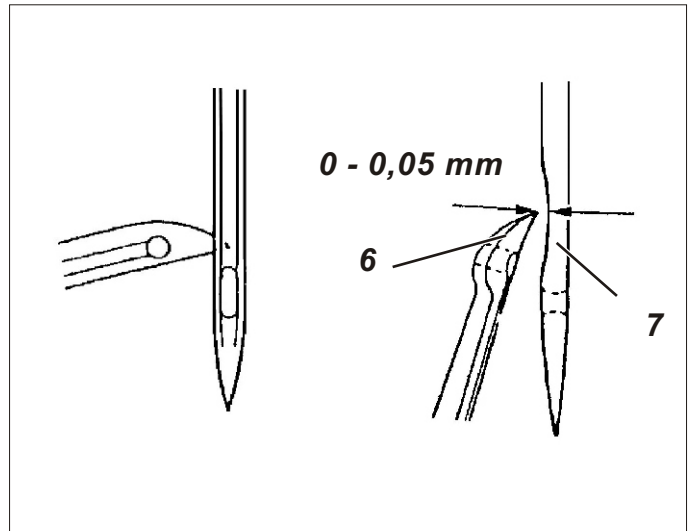
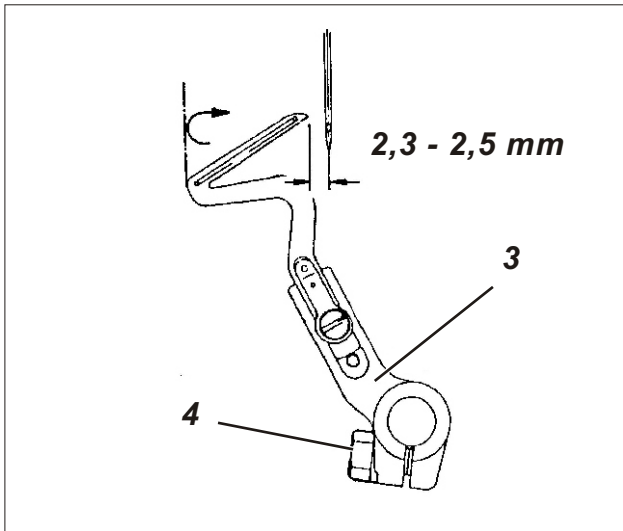

Adjustment in sewing direction

Standard checking

The distance between hook tip 6 and needle 7 should amount to 0.0 - 0.05 mm.

- Turn handwheel in direction of rotation until the hook tip is exactly at the level of the middle of the needle.
- Shift the hook support 3 in such a way that the distance between hook support and needle amounts to 0.0 - 0.05 mm.
- Check the cross-line adjustment once again and readjust, if necessary.
- Tighten screw 4.

2.2.2 Distance between right hook and needle

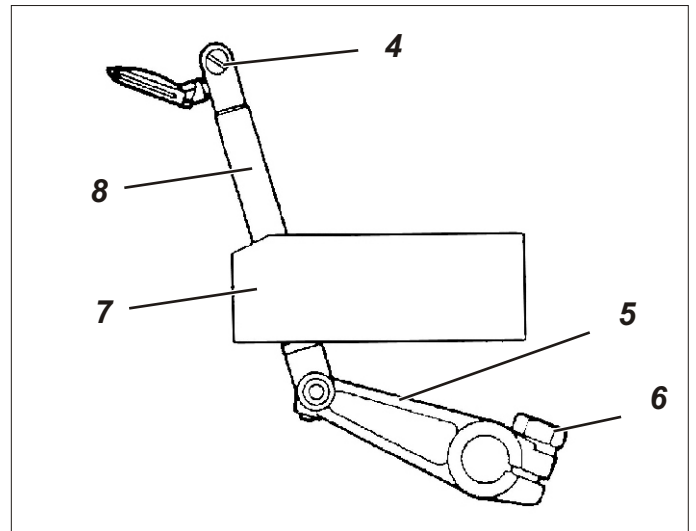
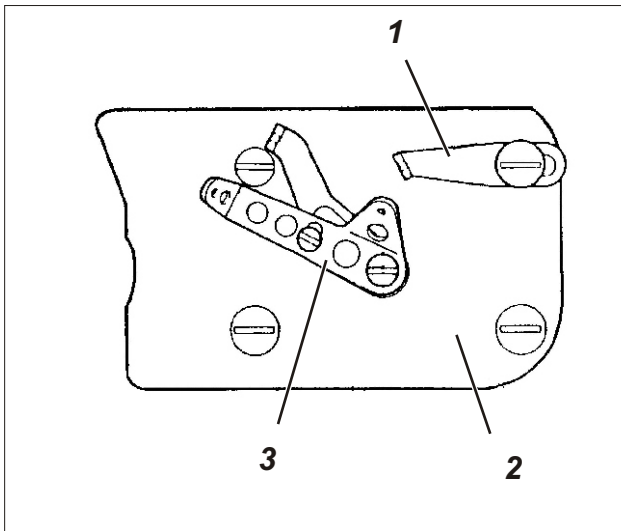

Caution: Risk of injury!

Switch the main switch off.

Check and adjust the hook only with the sewing station switched off.

Cross-line adjustment

3

Standard checking

When the **right** hook is in its top reverse point, the distance between hook tip 9 and the middle of the needle should amount to 4.3 - 4.5 mm.

- Screw off thread guides 1 and 3 as well as cover 2.
- Move the hook in its top dead centre by handwheel.
- Loosen screw 4 until the hook can just be pushed.
- Shift the hook in such a way that the hook shank (1) is flush with the right side of the hook holder.
- Loosen screw 6 a little.
- Turn lever 5 in such a way that there is a distance of 4.3 - 4.5 mm between hook tip and the middle of the needle.
Take care that the bar 8 in the bearing 7 does not move too heavy.
- Tighten screw 6.

Note

Do not yet tighten screw 4.

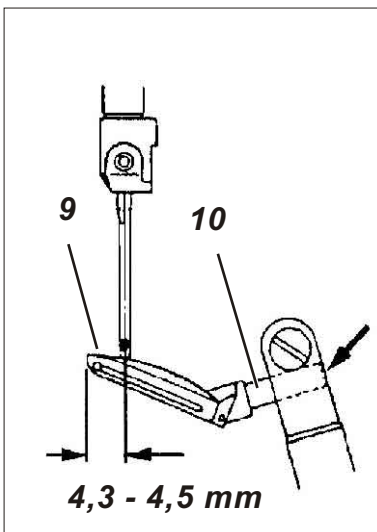

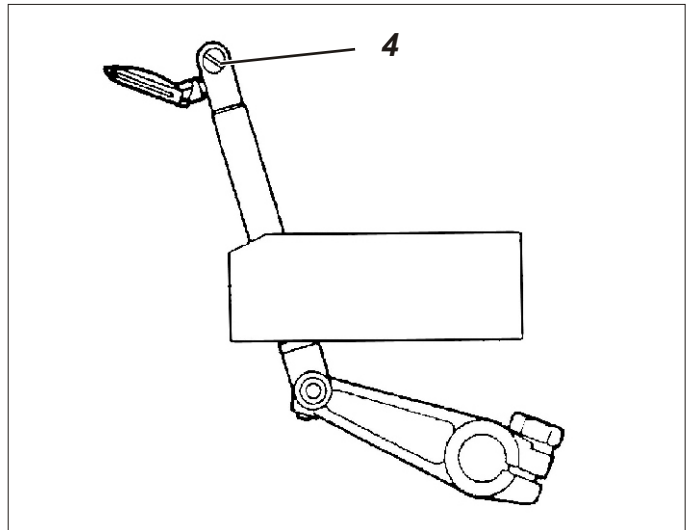
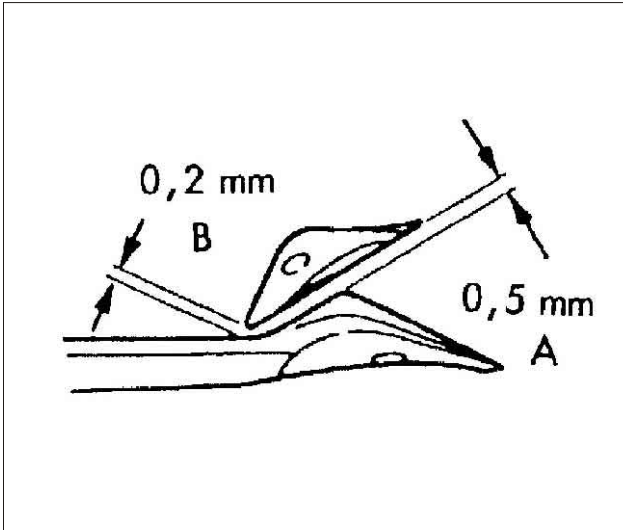

Adjustment in sewing direction

Standard checking

When the right hook crosses the left hook, the distance "A" should amount to 0.5 mm and the distance "B" to 0.2 mm.

Correction

- Turn handwheel in direction of rotation until the right hook crosses the left hook.
- Turn and shift the right hook in such a way that the distance "A" amounts to 0.5 mm and the distance "B" to 0.2 mm.
- Tighten screw 4 in this position.
- Check all adjustments once again and readjust, if necessary.
- Remount thread guides 1 and 3 as well as cover 2.
- Adjust thread guides according to chapter "thread regulation of the overlock hooks".

Note

The right overlock hook is dependent on the needle size.
Use hook No. 28 for needles Nm 60 - 80 and hook No. 22 for needles Nm 80 - 100.

2.3 Adjusting the needle protection

2.3.1 Hind needle protection

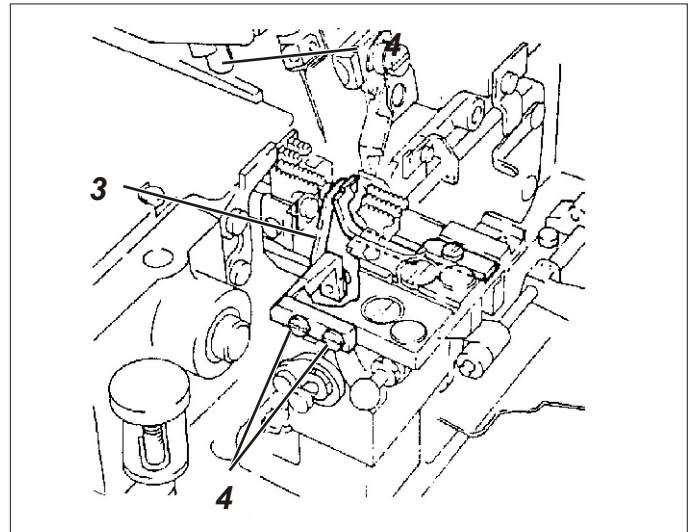
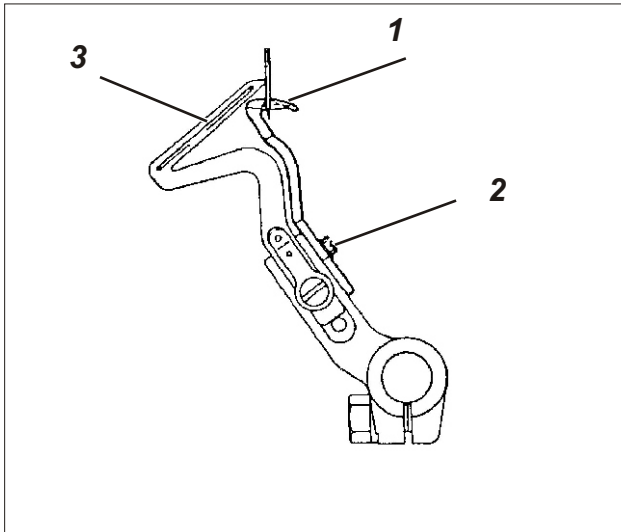

Caution: Risk of injury!

Switch the main switch off.

Check and adjust the needle protection only with the sewing station switched off.

Standard checking

When the tip of the left hook 3 is at the level of the middle of the needle, the needle protection 1 should abut on the needle. There should be a distance of 0.0 - 0.05 mm between hook tip and needle.

- Turn handwheel in direction of rotation until the hook tip points in the needle direction.
- Check the distance between hook tip and needle.

Correction of the mobile version

- Turn handwheel in direction of rotation until the hook tip points in the needle direction.
- Loosen screw 2.
- Shift the needle protection 1 in such a way that it abuts on the needle and there is a distance of 0.0 - 0.05 mm between hook tip and the middle of the needle.
- Tighten screw 1.

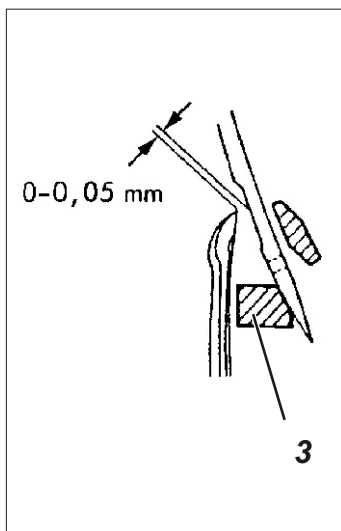

Correction of the stationary version

- Turn handwheel in direction of rotation until the hook tip points in the needle direction.
- Loosen screws 4.
- Shift the needle protection 3 in such a way that it abuts on the needle and there is a distance of 0.0 - 0.05 mm between hook tip and the middle of the needle.
- Tighten screws 4.

2.3.2 Front needle protection

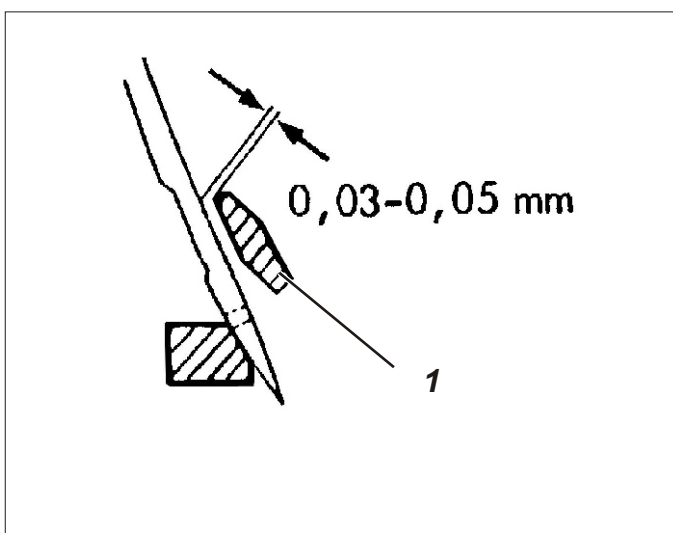
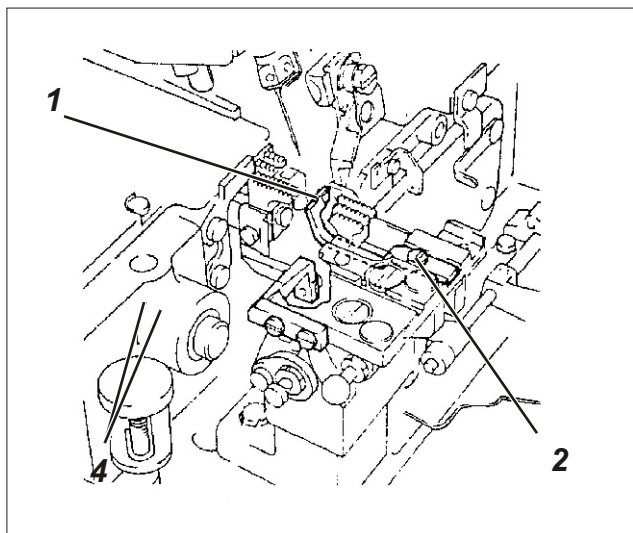

Caution: Risk of injury!

Switch the main switch off.

Check and adjust the needle protection only with the sewing station switched off.

Standard checking

In the lower dead centre of the needle the distance between needle protection 1 and needle should amount to 0.03 - 0.05 mm.

- Turn handwheel in direction of rotation until the needle is in its lower dead centre.
- Check the position of the front needle protection.

Correction

- Turn handwheel in direction of rotation until the needle is in its lower dead centre.
- Loosen screw 2.
- Shift the needle protection 1 in such a way that there is a distance of 0.03 - 0.05 mm between needle protection and needle.
- Tighten screw 2.

2.4 Adjusting the feed-dog

2.4.1 Feed-dog position

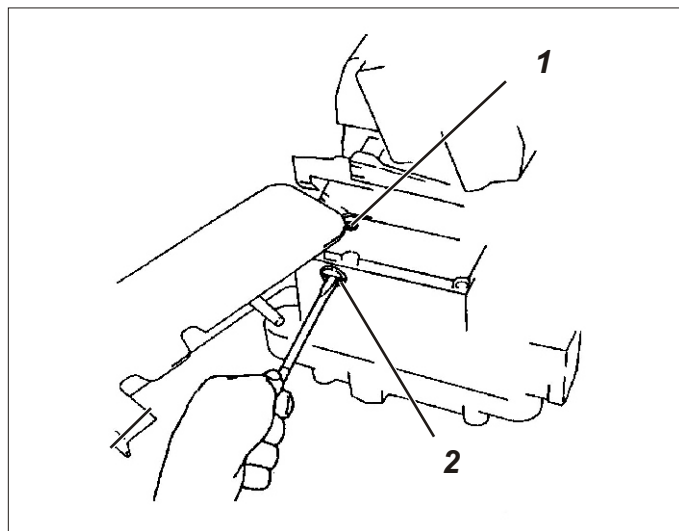
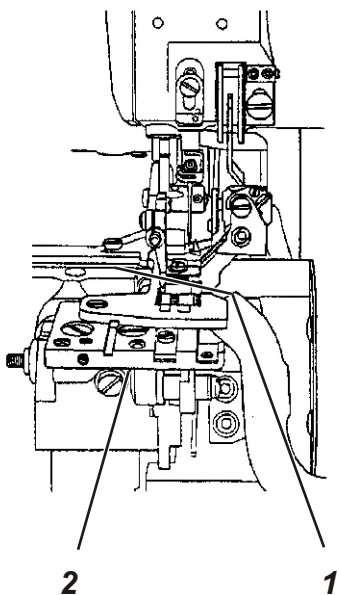

Caution: Risk of injury!

Switch the main switch off.

Check and adjust the feed-dog position only with the sewing station switched off.

3

Standard checking

In their highest position the feed-dogs should be horizontal.

- Turn handwheel in direction of rotation until the feed-dogs are in their highest position.
- Check the position of the feed-dogs.

Correction

- Turn handwheel in direction of rotation until the feed-dogs are in their highest position.
- Loosen screw 1.
- Turn screw 2.



Feed-dogs are horizontal



Feed-dogs are inclined backwards



Feed-dogs are inclined forwards

- Tighten screw 1.

2.4.2 Feed-dog height

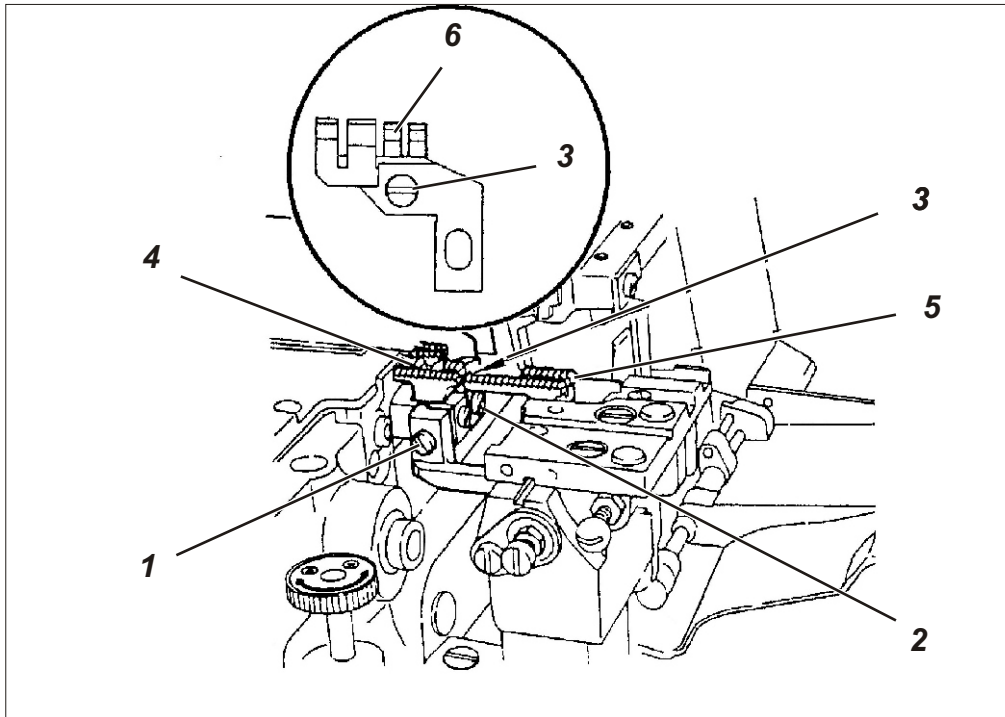

Caution: Risk of injury!

Switch the main switch off.

Check and adjust the feed-dog height only with the sewing station switched off.

Standard checking

When the feed-dogs are in their highest position, the teeth of the main feed-dog 4 should be 0.8 mm above the top edge of the throat plate, the teeth of the differential feed-dog 5 0.9 to 1.0 mm and the teeth of the auxiliary feed-dog 6 0.6 to 0.7 mm.

- Turn the handwheel in direction of rotation until the feed-dogs are in their highest position.
- Check the position of the feed-dogs to the throat plate.

Correction

- Unscrew throat plate.
- Loosen screws 1, 2 and 3 a little.
- Put throat plate on again.
- Set the height of the feed-dogs.
- Remove the throat plate.
- Tighten screws 1, 2 and 3.
- Put throat plate on again and tighten.

2.5 Presser foot Head EXT3216

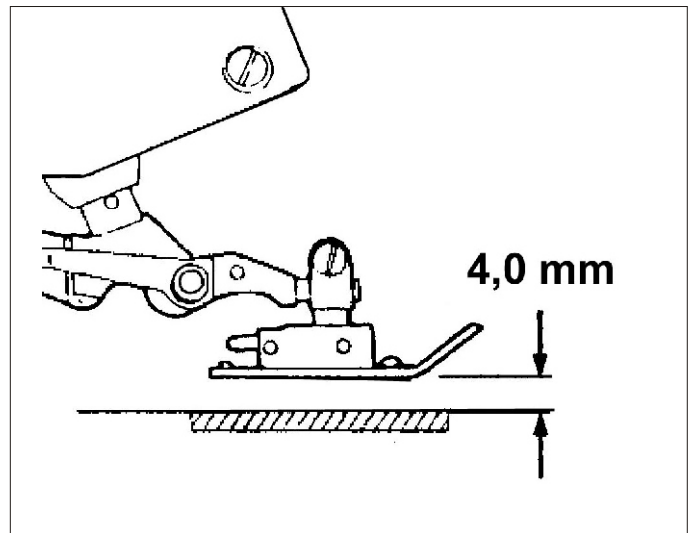
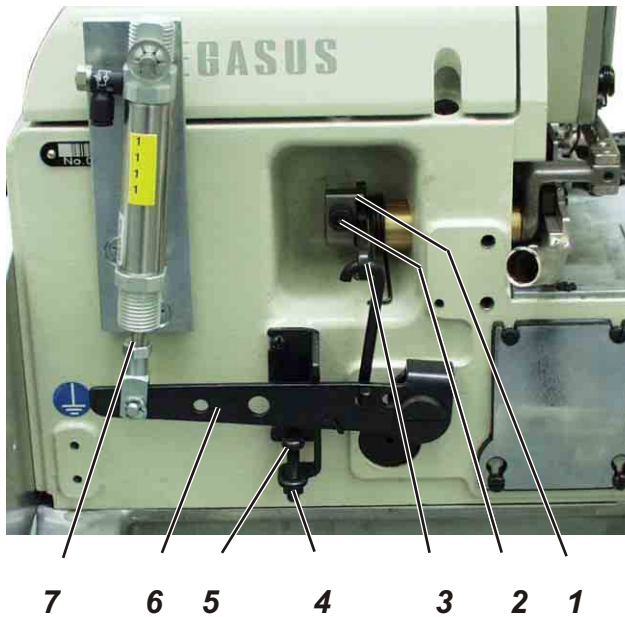

Caution: Risk of injury!

Switch the main switch off.

Check and adjust the presser foot lift only with the sewing station switched off.

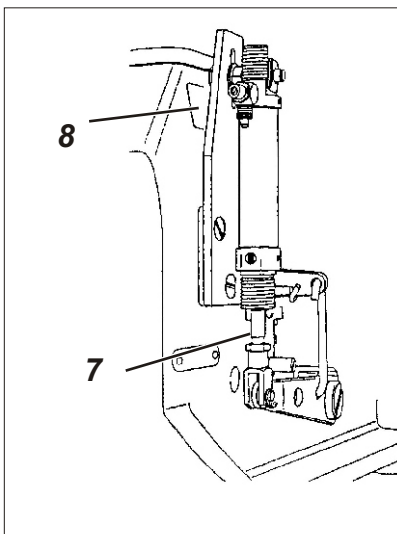

Standard

When the piston rod 7 is extended, the lever 6 should abut on screw 5 and the clearance under the sewing feet should amount to 4 mm.

Correction

- Loosen counternut 4 and screw the screw 5 down completely.
- Swivel the sewing foot in.
- Turn handwheel in direction of rotation until the teeth of the feed-dog are underneath the top edge of the throat plate.
- Loosen screw 2 and press ring 1 backwards as far as it will go.
- Tighten screw 2 in this position.
Take care that ring 1 and lever 3 have no axial backlash.
- Press lever 6 down until there is a distance of approx. 4 mm between sewing foot and throat plate.
- Let screw 5 abut on lever 6 in this position and fix it by a locknut.

Note

If lever 6 does not abut on screw 5 when the piston rod 7 of the cylinder is extended, please proceed as follows:

- Loosen nut 8.
- Shift cylinder 1 correspondingly.
- Tighten nut 8.

2.5.1 Presser foot



4

3

2

1

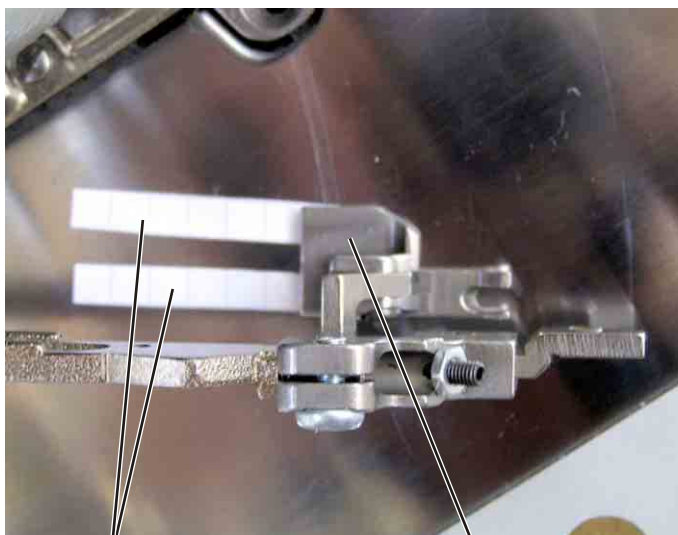

5

4



Caution: Risk of injury!

Switch the main switch off.

Check and adjust the presser foot only with the sewing station switched off.

Standard

The hinges of the hinged sewing foot must be free of clearance and smooth-running.

The front sewing foot sole 1 and the hind sewing foot soles 4 have to be in parallel position.

Correction of lateral inclination

- Remove the front sewing foot sole 1.
- Bring the head into position “needle down”.
- Place two approx. 5 mm wide paper strips 5 next to each other under the hind sewing foot sole 4.
- Adjust the lateral inclination in such a way that the inner paper strip is clamped a little less than the outer one and can be easily pulled out of the clamping of the sewing foot.

Compensation of the front and hind sewing foot sole

- Remount the front sewing foot sole 1.
- Bring the head into position “needle down”.
- Turn the setting screw 3 in such a way that the front sewing foot sole just rests on.

Inclination of the front sewing foot sole

The whole length of the front sewing foot sole should rest on the throat plate in the position “needle down”.

- Set the sewing foot sole with screw 2.

2.6 Upper and lower knife

2.6.1 Changing and adjusting the upper knife

Head EXT 32-16-03/233K

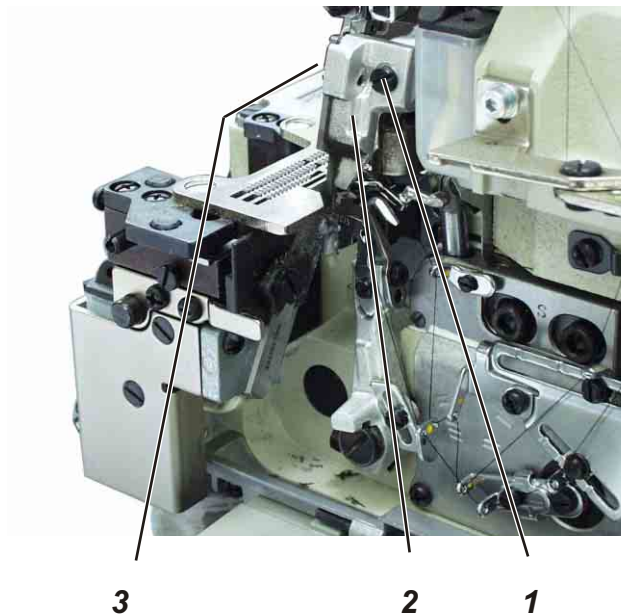

Caution: Risk of injury!

Switch the main switch off.

Change and adjust the upper knife only with the sewing station switched off.

3

Standard

In the lowest position of the upper knife the front edge of the blade should be 0.5 to 1.0 mm underneath the top edge of the throat plate.

Correction

- Turn the handwheel until the needles are in their top reverse point and swivel the sewing foot out.
- Screw off screw 1.
- Remove the knife holder 2 with the knife.
- Loosen screw 3 and remove the knife.
- Insert a new, sharp knife and tighten with screw 3.
- Insert knife holder 2 and tighten slightly with screw 1.
- Turn the handwheel until the knife is in its lowest position.
- Shift the knife in such a way that it slightly abuts on the lower knife and the front edge of the blade is approx. 0.5 to 1.0 mm underneath the top edge of the throat plate.

2.6.2 Changing and adjusting the lower knife

Head EXT 3216-03/233K

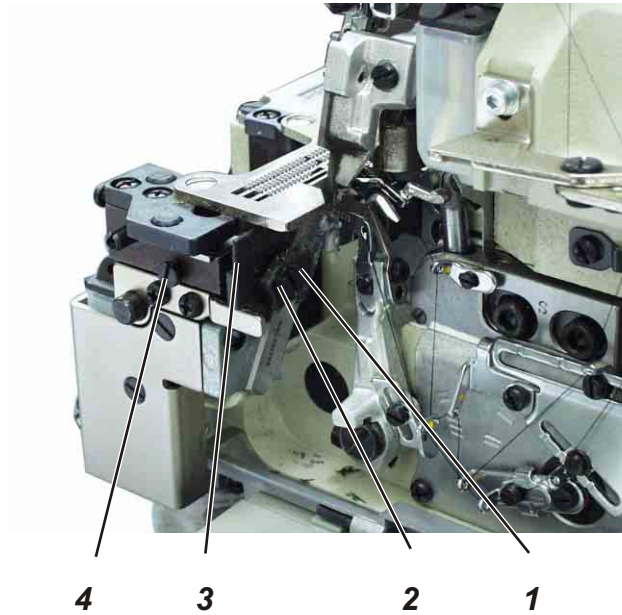

Caution: Risk of injury!

Switch the main switch off.

Change and adjust the lower knife only with the sewing station switched off.

Standard

The blade of the lower knife has to be flush with the top edge of the throat plate.

Correction

- Remove the fabric sliding sheet.
- Swivel the sewing foot out.
- Loosen screw 4.
- Draw the holder of the lower knife 3 to the left as far as it will go and tighten screw 4 slightly.
- Loosen screw 2 and remove the old knife.
- Insert a new, sharp knife in guide 1 in such a way that the blade is flush with the top edge of the throat plate.
- Tighten screw 2.
- Turn the handwheel until the upper knife is in its highest position.
- Loosen screw 4 and let the holder of the lower knife 3 spring against the upper knife.
- Tighten screw 4.

2.7 Thread regulation of overlock hook

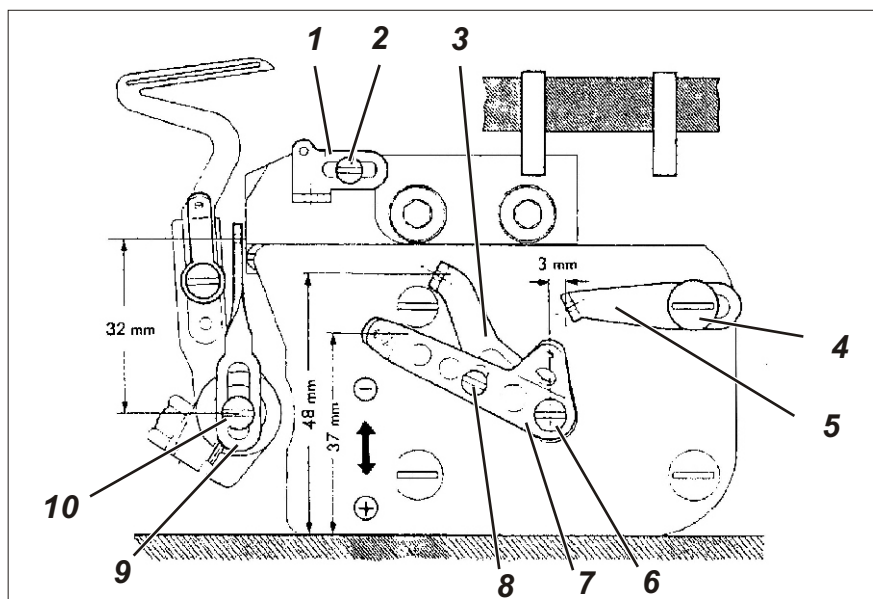

Caution: Risk of injury!

Switch the main switch off.

Check and adjust the thread regulation only with the sewing station switched off.

3

Standard

The position of the individual thread guides or thread pullers is dependent on the material, the sewing thread and the stitch type. Therefore the following setting values have to be regarded as standard values only.

Correction

- Turn the handwheel until the right hook is in its top reverse point.
- Loosen screw 10 and shift the thread puller 9 in such a way that there is a distance of approx. 32 mm between the middle of the screw and the middle of the eyelet.
- Tighten screw 10.
Take care that the thread puller 9 is in vertical position.
- Loosen screws 6 and 8 a little.
- Position the thread pullers 3 and 7 as shown in the illustration.
- Tighten screws 6 and 8.
- Loosen screw 4 a little.
- Position the thread guide 5 as shown in the illustration.
- Tighten screw 4.
- Loosen screw 2 a little.
- Shift the thread guide 1 in such a way that the screw 2 is in the centre of the longitudinal hole.
- Tighten screw 2.

Note

If the seam requires more or less thread, shift the thread pullers 3 and 7 in the direction "+" or "-" respectively.

3. Adjusting the engineered sewing station

3.1 Adjusting the light barrier



2

1



5

4

3



Caution: Risk of injury!

The adjustment of the light barrier is done with the sewing station switched on.

Carry out adjustment and function test with utmost caution.



6

5

Aligning the light barrier

The light barrier 2 has to be aligned to the area 1 of the machine head.

- Loosen screws 4 and 5.
- Align the light barrier support 3 correspondingly.
- Tighten screws 4 and 5.

Adjusting the light barrier intensity

- Turn the sensitivity potentiometer 5 at the front above the light-emitting diode 6 to the left stop (minimum sensitivity).
- Turn the potentiometer in clockwise direction until the light-emitting diode 6 switches on.
- For a safe light barrier function turn the potentiometer once again in clockwise direction.

If the light-emitting diode does not shine, the light barrier should be cleaned, reset or exchanged.

3.2 Adjusting the material stop

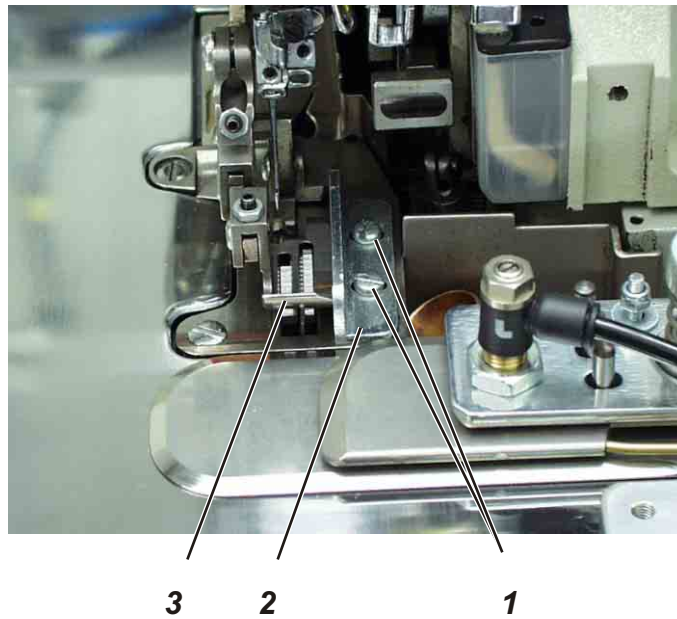

Caution: Risk of injury!

Switch the main switch off.

Adjust the material stop only with the sewing station switched off.

3

Standard

The material stop 2 must completely abut on the sewing foot 3 so that the material cannot be pushed upward between sewing foot 3 and stop 2.

Correction

- Loosen screws 1.
- Push the material stop 2 completely against the sewing foot 3.
- Tighten screws 1.

3.3 Adjusting the contour guide



2

1



1

3



Caution: Risk of injury!

Switch the main switch off.

Adjust the contour guide only with the sewing station switched off.

Standard

The contour guide 1 should move forward as far as to ensure that both material plies 2 are always guided safely when sewing the contour.

Correction of the swivelling width

- Loosen the clamping lever 3.
- Shift the contour guide 1 correspondingly.
- Tighten the clamping lever 3.

3.4 Direct sewing drive

3.4.1 Setting the reference

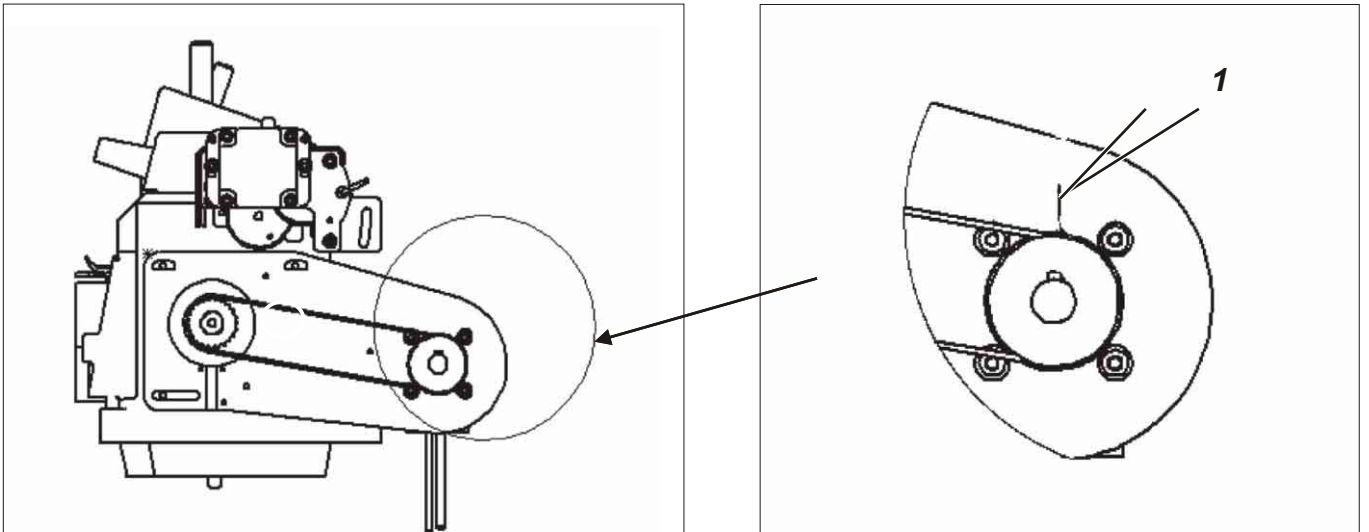

Caution: Risk of injury!

Switch the main switch off.

Check and adjust the hook setting only with the sewing unit switched off.

3

Standard

When the needle is in the position “**7 mm after the bottom dead centre**”, the drive belt has to be put on in such a way that the feather key 2 in the motor shaft points to the marking 1 in the motor casing.

Correction

- Remove the toothed belt.
- Move the needle bar in the position “**7 mm after the bottom dead centre**” by handwheel.
- Turn the motor shaft in such a way that the feather key 2 in the motor shaft points to the marking 1 in the motor casing.
- Put the toothed belt on again.

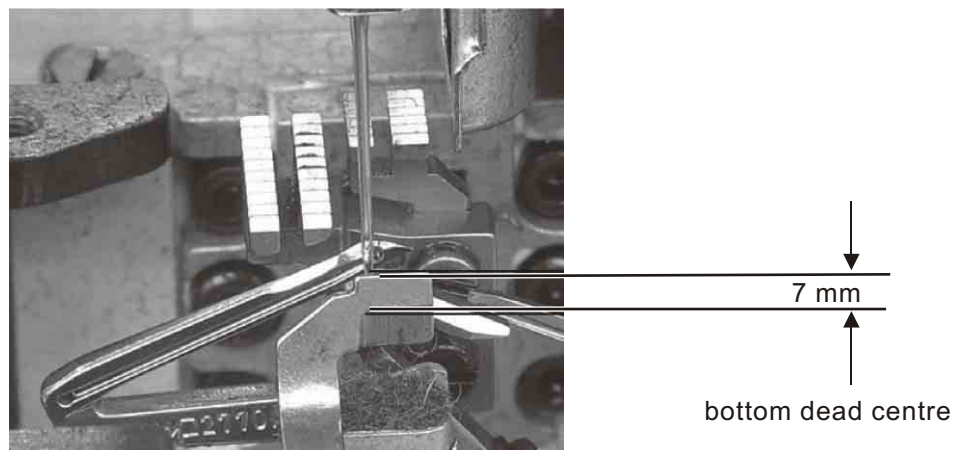

4. Oil lubrication



Caution: Risk of injury !

Oil can cause skin eruption.
Avoid a longer contact with the skin.
Wash yourself thoroughly after a contact.



ATTENTION !

The handling and disposal of mineral oils is subject to legal regulations.
Deliver used oil to an authorized collecting station.
Conserve your environment.
Be careful not to spill any oil.

4.1 Oil change and oil filter change

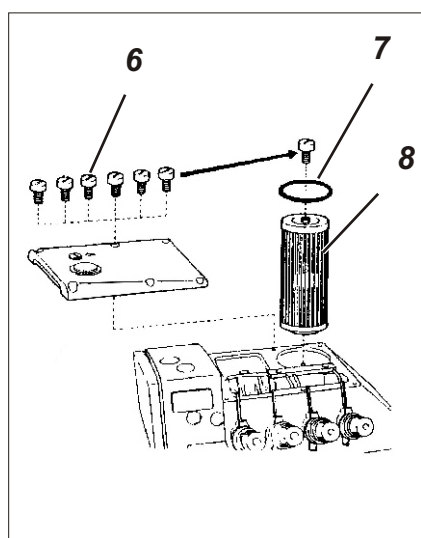
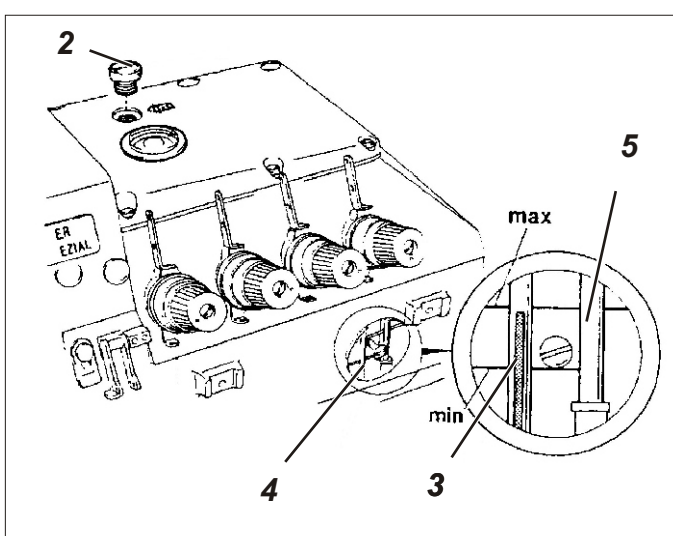
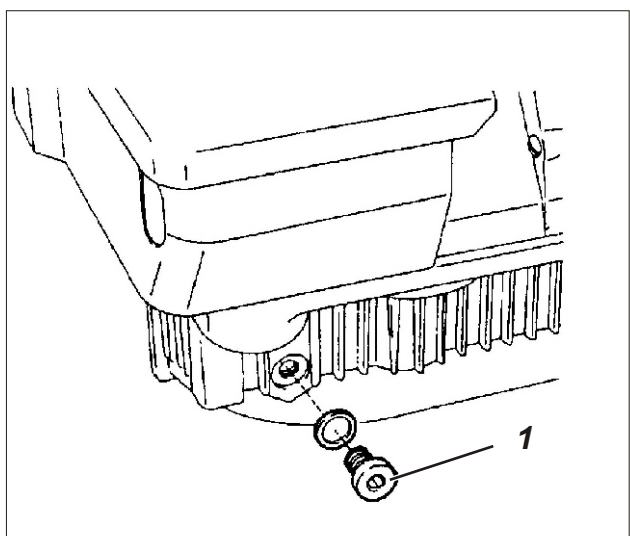

4 weeks after the initial start-up and subsequently every two years an oil change has to be carried out with the machine head disassembled.
The oil filter should be cleaned or exchanged every two years.

Note

If the oil pressure gauge 5 does not move downwards when the machine head is running or if the oil is dirty, the oil filter has to be cleaned or exchanged.

- Unscrew the drain screw 1 and collect the used oil in a collecting basin.
- Screw drain screw 1 in again.
- Unscrew screws 6 of the cover.
- Screw one of the screws 6 in filter 8 and unscrew the filter.
- Clean or exchange filter 8.
- Insert a new gasket 7, put the cover on again and tighten.
- Unscrew screw 2 and fill in oil until the point of the oil level indicator 3 has reached the upper marking of the oil inspection glass 4.
We recommend to use oil with a density of 0.865 g/cm^3 at 15°C .
- Insert screw 2 again.

5. Maintenance



Caution: Risk of injury !

Switch the main switch off.

The maintenance of the sewing station must only be done with the machine switched off.

The daily or weekly maintenance work (cleaning and oiling) to be carried out by the operators of the sewing unit is described in the operating instructions (chapter 8). This is listed in the following table for the sake of completeness only.

Maintenance work to be carried out	Operating hours			
	8	40	160	500
<p>Machine head</p> <ul style="list-style-type: none"> - Remove sewing dust and thread remainders - Check the oil level - First oil change - Subsequent oil change 	X	X	X	
		every 2 years		
<p>Control box</p> <ul style="list-style-type: none"> - Remove sewing dust and thread remainders - Keep the fan grill clean 	X			
	X			
<p>Suction device</p> <ul style="list-style-type: none"> - Empty the container - Clean the zone under the fabric sliding sheet from sewing dust and thread remainders 	X	X		
<p>Pneumatic system</p> <ul style="list-style-type: none"> - Check the water level in the pressure regulator - Clean the filter insert in the maintenance unit - Make leak test of the system 	X			X

Note: