



1280-7

1281-7

Betriebsanleitung

**IMPORTANT
READ CAREFULLY BEFORE USE KEEP
FOR FUTURE REFERENCE**

All rights reserved.

Property of Dürkopp Adler GmbH and protected by copyright. Any reuse of these contents, including extracts, is prohibited without the prior written approval of Dürkopp Adler GmbH.

Copyright © Dürkopp Adler GmbH 2023

1	About these instructions.....	5
1.1	For whom are these instructions intended?	5
1.2	Representation conventions – symbols and characters	6
1.3	Other documents	7
1.4	Liability.....	8
2	Safety	9
2.1	Basic safety instructions	9
2.2	Signal words and symbols used in warnings	10
3	Machine description	13
3.1	Components of the machine	13
3.2	Proper use	13
3.3	Declaration of Conformity	14
4	Operation.....	15
4.1	Preparing the machine for operation.....	15
4.2	Switching on and off the machine	15
4.3	Operating the machine head.....	16
4.4	Threading diagram.....	17
4.4.1	Disconnecting the compressed air supply	19
4.5	Disassembling and assembling the fabric sliding plate.....	20
4.6	Edge guide.....	22
4.6.1	Mechanical edge guide	22
4.6.2	Pneumatic edge guide (options 1280 and 1281)	23
4.6.3	Operating the pneumatic edge guide.....	24
4.7	Contour guide	25
4.7.1	Adjusting the contour guide	25
4.7.2	Operating the contour guide	27
4.8	Knee button (option for 1280)	28
4.9	Differential feed.....	29
4.9.1	Fullness distribution controlled by the stepper motor (option) .	29
4.9.2	Pneumatically controlled fullness distribution (option)	33
4.10	Light barrier.....	35
4.10.1	Aligning the light barrier	35
4.10.2	Adjusting the light barrier intensity	36
4.11	Laser marking lamp	37
4.11.1	Position of laser marking lamp.....	37
4.12	Thread monitor.....	38
4.13	Stacker.....	39
4.13.1	Operating the flip stacker	39
4.13.2	Operating the clamping stacker	40
4.13.3	Operating the alternating stacker.....	42
4.14	Air nozzles	44
4.14.1	Adjusting the air nozzles 1280 in the tabletop	44
4.14.2	Adjusting the air nozzles 1281 in the tabletop	45
4.14.3	Adjusting the air supply.....	46
4.14.4	Adjusting the air supply intensity.....	46
4.15	Transport station	50
4.15.1	Adjusting the puller	52
4.15.2	Operating the puller	52
4.15.3	Operating the roll-out device.....	53

4.16	Pneumatic swing out device with stamp (option 1280)	55
4.17	Mouse station with guide rail and retrieval device (1281)	57
4.17.1	Aligning the guide rail	58
4.17.2	Operating the mouse station	59
4.17.3	Retrieval device of the mouse station	61
4.18	Sewing	62
4.18.1	Operating the workstation: 1280-7	63
4.18.2	Operating the workstation: 1281-7	66
4.19	Foot pedal	70
5	Programming Commander Pro	71
5.1	Commander Pro control panel	71
5.1.1	Starting up the screen	71
5.2	LED light strip	71
5.3	Navigating the Commander Pro control panel	72
5.3.1	Symbols and tiles	74
5.4	Locking and activating the machine functions	77
5.5	Calling up threading mode	78
5.5.1	Threading diagram	79
5.6	Entering numerical values	80
5.7	Changing program or sequence names	81
5.8	Navigation menu	82
5.9	Settings	82
5.9.1	User Configuration	83
5.9.2	Setting the language	84
5.9.3	Adjusting the brightness	85
5.9.4	Adjusting the audio volume	85
5.9.5	Information	86
5.9.6	Machine Configuration	88
5.9.7	Service	91
5.9.8	Global parameters	98
5.9.9	Software update	105
5.9.10	Manual data transfer	106
5.9.11	Searching settings	109
5.10	Tutorials	109
5.11	Login/Logout	111
5.12	Software operating modes	112
5.12.1	Buttons in the operating modes	112
5.13	Piece counter	114
5.14	Program parameters	115
5.14.1	User interface Program parameters	115
5.14.2	Current Sequence/Current Program	116
5.14.3	Program templates	117
5.14.4	Copying program parameters	120
5.14.5	Search	122
5.14.6	Resetting program parameters	122
5.14.7	Program parameter search	123
5.14.8	Adjusting the program parameters	123
5.14.9	Programming the pneumatic differential bottom feed	138
5.14.10	Programming the differential bottom feed controlled by the stepper motor	140
5.14.11	Programming the pneumatic differential top feed	143

5.14.12	Programming the differential top feed controlled by the stepper motor.....	145
5.14.13	Setting options for stop in seam.....	148
5.15	Sequence programming.....	150
5.15.1	Sequence programming user interface.....	150
5.15.2	Programs in the sequence.....	152
5.15.3	Adding programs to a sequence.....	152
5.15.4	Removing a program from the sequence.....	154
5.15.5	Program position.....	156
5.15.6	Sequence search.....	156
5.15.7	Copying sequences.....	157
5.16	Quick access panel.....	157
5.16.1	Configuration of the quick access icons.....	157
5.17	Using manual data transfer.....	159
5.17.1	Exporting data.....	160
5.17.2	Importing data.....	163
5.18	Software update for the control panel.....	168
5.19	Software update for the control.....	170
5.19.1	Checking the installed software version.....	170
5.19.2	Performing a software update.....	171
6	Maintenance.....	173
6.1	Cleaning.....	174
6.2	Lubricating.....	176
6.2.1	Checking the lubrication of the machine head.....	177
6.3	Servicing the pneumatic system.....	177
6.3.1	Adjusting the operating pressure.....	177
6.3.2	Draining the water condensation.....	178
6.3.3	Cleaning the filter element.....	179
6.4	Parts list.....	180
7	Setup.....	181
7.1	Checking the scope of delivery.....	181
7.2	Removing the transport locks.....	181
7.3	Adjusting the working height.....	182
7.4	Assembling the reel stand.....	184
7.5	Adjusting the knee button.....	185
7.6	Assembling the flip stacker (optional).....	186
7.7	Assembling the alternating stacker (optional).....	187
7.8	Delivery table.....	190
7.8.1	Assembling the delivery table 1280.....	190
7.8.2	Assembling the delivery table 1281.....	192
7.9	Assembling the clamping stacker tray extension (optional)...	193
7.10	Electrical connection.....	194
7.11	Pneumatic connection.....	195
7.11.1	Assembling the compressed air maintenance unit.....	195
7.11.2	Adjusting the operating pressure.....	195
7.12	Performing a test run.....	196
8	Decommissioning.....	197

9	Disposal.....	199
10	Troubleshooting.....	201
10.1	Customer Service	201
10.2	Messages of the software	201
10.3	Errors in sewing process.....	207
11	Technical data	209
11.1	Requirements for fault-free operation	209
11.2	Recommended threads.....	210

1 About these instructions



These instructions have been prepared with utmost care. They contain information and notes intended to ensure long-term and reliable operation.

Should you notice any discrepancies or if you have improvement requests, then we would be glad to receive your feedback through **Customer Service** ( p. 201).

Consider the instructions as part of the product and store them in a place where they are readily available.

1.1 For whom are these instructions intended?

These instructions are intended for:

- Operators:
This group is familiar with the machine and has access to the instructions. Specifically, chapter **Operation** ( p. 15) is important for the operators.
- Specialists:
This group has the appropriate technical training for performing maintenance or repairing malfunctions. Specifically, the chapter **Setup** ( p. 181) is important for specialists.

Service Instructions are supplied separately.

With regard to minimum qualification and other requirements to be met by personnel, please also follow the chapter **Safety** ( p. 9).

1.2 Representation conventions – symbols and characters

Various information in these instructions are represented or highlighted by the following characters in order to facilitate easy and quick understanding:



Proper setting

Specifies proper setting.



Disturbances

Specifies the disturbances that can occur from an incorrect setting.



Cover

Specifies which covers must be disassembled in order to access the components to be set.



Steps to be performed when operating the machine (sewing and equipping)



Steps to be performed for service, maintenance, and installation



Steps to be performed via the software control panel

The individual steps are numbered:

1. First step
 2. Second step
 - ...
- The steps must always be followed in the specified order.
- Lists are marked by bullet points.



Result of performing an operation

Change on the machine or on the display/control panel.



Important

Special attention must be paid to this point when performing a step.



Information

Additional information, e.g. on alternative operating options.



Order

Specifies the work to be performed before or after a setting.

References



Reference to another section in these instructions.

Safety

Important warnings for the user of the machine are specifically marked. Since safety is of particular importance, hazard symbols, levels of danger and their signal words are described separately in the chapter **Safety** (📖 p. 9).

Location information If no other clear location information is used in a figure, indications of **right** or **left** are always from the user's point of view.

1.3 Other documents

The machine includes components from other manufacturers. Each manufacturer has performed a hazard assessment for these purchased parts and confirmed their design compliance with applicable European and national regulations. The proper use of the built-in components is described in the corresponding manufacturer's instructions.

1.4 Liability

All information and notes in these instructions have been compiled in accordance with the latest technology and the applicable standards and regulations.

Dürkopp Adler cannot be held liable for any damage resulting from:

- Breakage and transport damages
- Failure to observe these instructions
- Improper use
- Unauthorized modifications to the machine
- Use of untrained personnel
- Use of unapproved parts

Transport

Dürkopp Adler cannot be held liable for breakage and transport damages. Inspect the delivery immediately upon receiving it. Report any damage to the last transport manager. This also applies if the packaging is not damaged.

Leave machines, equipment and packaging material in the condition in which they were found when the damage was discovered. This will ensure any claims against the transport company.

Report all other complaints to Dürkopp Adler immediately after receiving the product.

2 Safety

This chapter contains basic information for your safety. Read the instructions carefully before setting up or operating the machine. Be sure to follow the information in the safety instructions. Failure to do so can result in serious injury and property damage.



2.1 Basic safety instructions

The machine may only be used as described in these instructions.

The instructions should be available at the machine's location at all times.

Work on live components and equipment is prohibited. Exceptions are defined in the DIN VDE 0105.

For the following work, switch off the machine at the main switch or disconnect the power plug:

- Replacing the needle or other sewing tools
- Leaving the workstation
- Performing maintenance work and repairs
- Threading

Missing or faulty parts could impair safety and damage the machine. Only use original parts from the manufacturer.

Transport Use a lifting carriage or stacker to transport the machine. Raise the machine max. 20 mm and secure it to prevent it from slipping off.

Setup The connecting cable must have a power plug approved in the relevant country. The power plug may only be assembled to the power cable by qualified specialists.

Obligations of the operator Follow the country-specific safety and accident prevention regulations and the legal regulations concerning industrial safety and the protection of the environment.

All the warnings and safety signs on the machine must always be in legible condition. Do not remove!

Missing or damaged warnings and safety signs must be replaced immediately.

Requirements to be met by the personnel Only qualified specialists may be used for:

- Setting up the machine/putting the machine into operation
- Performing maintenance work and repairs
- Performing work on electrical equipment

Only authorized persons may work on the machine and must first have understood these instructions.

- Operation** Check the machine during operating for any externally visible damage. Stop working if you notice any changes to the machine. Report any changes to your supervisor. Do not use a damaged machine any further.
- Safety equipment** Safety equipment should not be disassembled or deactivated. If it is essential to disassemble or deactivate safety equipment for a repair operation, it must be assembled and put back into operation immediately afterward.
-



2.2 Signal words and symbols used in warnings



Warnings in the text are distinguished by color bars. The color scheme is based on the severity of the danger. Signal words indicate the severity of the danger.

Signal words Signal words and the hazard they describe:

Signal word	Meaning
DANGER	(with hazard symbol) If ignored, fatal or serious injury will result
WARNING	(with hazard symbol) If ignored, fatal or serious injury can result
CAUTION	(with hazard symbol) If ignored, moderate or minor injury can result
CAUTION	(with hazard symbol) If ignored, environmental damage can result
NOTICE	(without hazard symbol) If ignored, property damage can result

Symbols The following symbols indicate the type of danger to personnel:

Icon	Type of danger
	General
	Electric shock

Icon	Type of danger
	Puncture
	Crushing
	Environmental damage

Examples Examples of the layout of warnings in the text:

DANGER



Type and source of danger!

Consequences of non-compliance.

Measures for avoiding the danger.

↪ This is what a warning looks like for a hazard that will result in serious injury or even death if ignored.

WARNING



Type and source of danger!

Consequences of non-compliance.

Measures for avoiding the danger.

↪ This is what a warning looks like for a hazard that could result in serious or even fatal injury if ignored.

CAUTION



Type and source of danger!

Consequences of non-compliance.

Measures for avoiding the danger.

↪ This is what a warning looks like for a hazard that could result in moderate or minor injury if the warning is ignored.

CAUTION



Type and source of danger!

Consequences of non-compliance.

Measures for avoiding the danger.

- ↪ This is what a warning looks like for a hazard that could result in environmental damage if ignored.

NOTICE

Type and source of danger!

Consequences of non-compliance.

Measures for avoiding the danger.

- ↪ This is what a warning looks like for a hazard that could result in property damage if ignored.

3 Machine description

3.1 Components of the machine

Fig. 1: Components of the machine

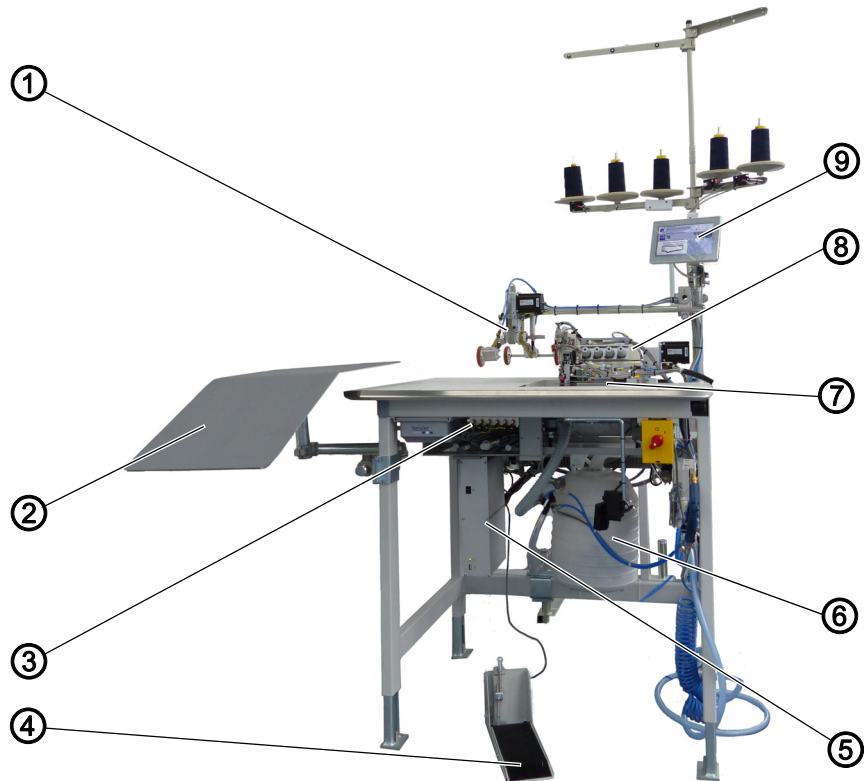

- | | |
|--|------------------------------|
| (1) - Transport station | (5) - Control |
| (2) - Side sewing material support surface | (6) - Dirt suction container |
| (3) - Table air nozzle setting/throttle valves | (7) - Contour guide |
| (4) - Pedal | (8) - Machine head |
| | (9) - Control panel |

3.2 Proper use

WARNING



Risk of injury from live, moving and cutting parts as well as from sharp parts!

Improper use can result in electric shock, crushing, cutting and punctures.

Follow all instructions provided.

NOTICE**Non-observance will lead to property damage!**

Improper use can result in material damage at the machine.

Follow all instructions provided.

The machine may only be used with sewing material that satisfies the requirements of the specific application at hand.

The machine is intended only for use with dry sewing material. The sewing material must not contain any hard objects.

The needle thicknesses permissible for the machine are listed in the **Technical data** (📖 p. 209) chapter.

The seam must be completed with a thread that satisfies the requirements of the specific application at hand.

The machine is intended for industrial use.

The machine may only be set up and operated in dry conditions on well-maintained premises. If the machine is operated on premises that are not dry and well-maintained, then further measures may be required which must be compatible with DIN EN 60204-31.

Only authorized persons may work on the machine.

Dürkopp Adler cannot be held liable for damages resulting from improper use.

3.3 Declaration of Conformity

The machine complies with European regulations ensuring health, safety, and environmental protection as specified in the declaration of conformity or in the declaration of incorporation.



4 Operation

The operating sequence consists of several different steps. Fault-free operation is necessary in order to achieve a good sewing result.

4.1 Preparing the machine for operation

WARNING



Risk of injury from moving, cutting and sharp parts!

Crushing, cutting and punctures are possible.

If possible, make preparations only when the machine is switched off.

Complete the following steps in preparation of sewing before starting to work:

- Inserting or changing the needle
- Threading the needle thread
- Threading the hook thread
- Adjusting the thread tension

4.2 Switching on and off the machine

Fig. 2: Switching on and off the machine

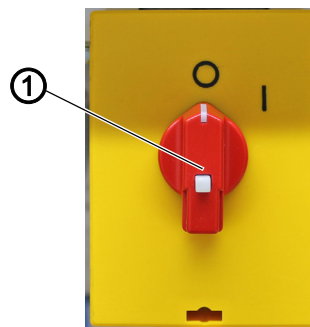

(1) - Main switch



To switch the machine on and off:

1. Turn the main switch (1) to the **I** position.
 - ↪ The machine starts up.
The control and the control panel of the machine start up.
 - ↪ The machine performs a reference run and is afterwards ready for sewing.
2. Turn the main switch (1) to the **O** position.
 - ↪ The machine switches off.

4.3 Operating the machine head

WARNING



Risk of injury from sharp and moving parts!

Puncture or crushing possible.

If possible, operate the machine head only when the machine is switched off.



Information

The operation of the machine head (needle insertion or change, threading of needle thread and hook thread etc.) is described in the separately included Pegasus Operating Instructions.

The Pegasus Operating Instructions are included in the accessories of the machine.

4.4 Threading diagram



Information

You can use the control panel to open the threading diagram (📖 p. 79).

Fig. 3: Threading diagram (1)

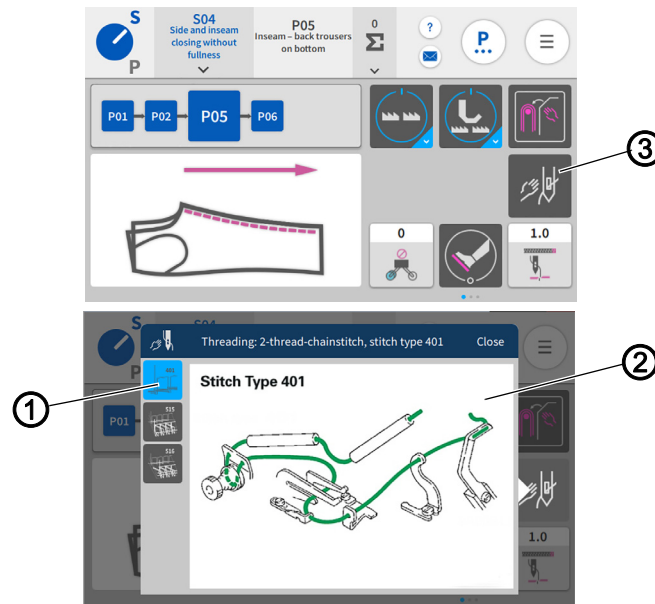

(1) - *Stitch type*

(2) - *Threading diagram*

(3) - *Threading mode*



To access the threading diagram in the machine head:



1. Activate *threading mode* (3) (📖 p. 78) on the control panel.

↪ The user interface with the *threading diagram* (2) opens.



Important

You will know that *threading mode* (3) is active when the user interface with the *threading diagram* (2) is shown on the display.

↪ All relevant machine functions are set to safety stop in order to be able to thread the machine.

↪ You can select the *Stitch type* (1) you wish to use in the *threading diagram* (2) (📖 p. 79).

↪ The edge guide in its initial position (4) automatically moves to the correct position so that you can open the cover (7).



2. Remove the fabric sliding plate (📖 p. 20).

3. Pull down the suction hose (5) to remove it.

Fig. 4: Threading diagram (2)

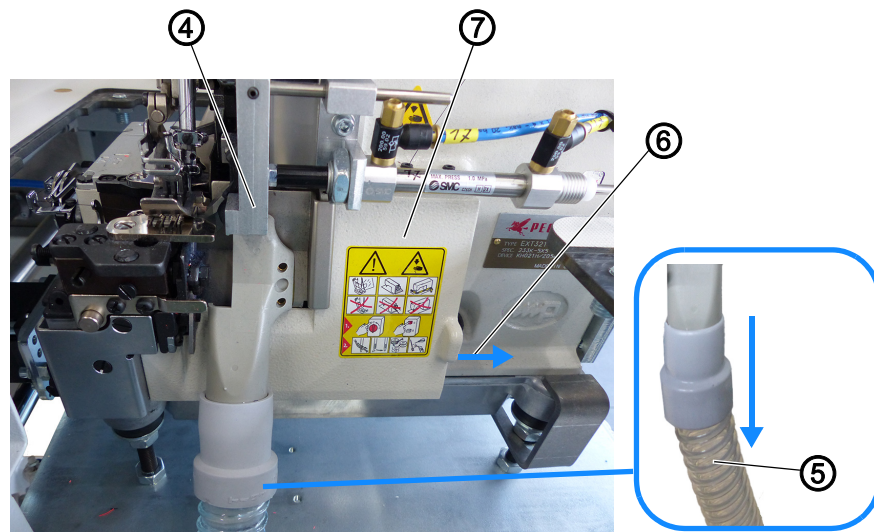

- (4) - Edge guide in initial position
 (5) - Suction hose
 (6) - Slide to the right
 (7) - Cover



Disturbance

You will not be able to open the cover (7) if the pneumatic edge guide is in its initial position (4). You can briefly disconnect the compressed air supply (📖 p. 19) to manually move the edge guide (8) towards the sewing foot.

4. Slide the cover (7) to the right (6).
5. The cover (7) opens towards the bottom.

Fig. 5: Threading diagram (3)

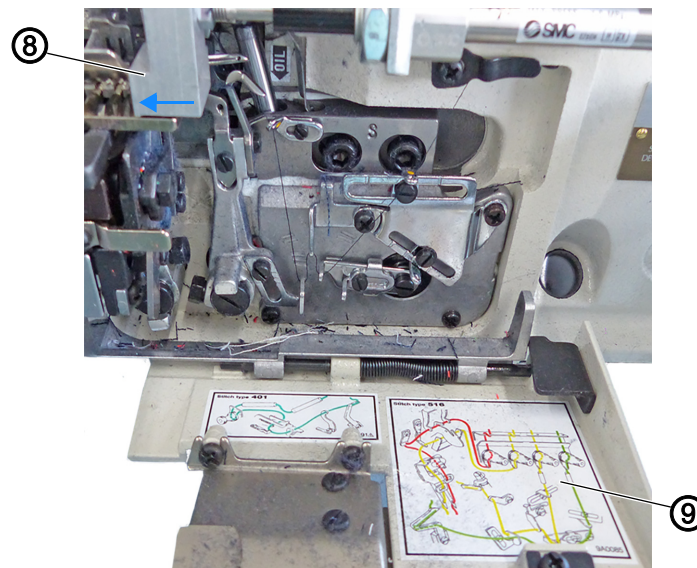



- (8) - Edge guide
 (9) - Threading diagram

6. The threading diagram (9) for the machine head is shown on the inside of the cover (7).
- 👉 The types of stitches are grouped by colors.



To restore the machine head to sewing readiness after threading is complete:

1. Fold up the cover (7).
- ↳ The cover latches into place.
2. Place the suction hose (5).
3. Place the fabric sliding plate ( p. 20).
4. Connect the compressed air supply ( p. 19).

4.4.1 Disconnecting the compressed air supply

Fig. 6: Disconnecting the compressed air supply

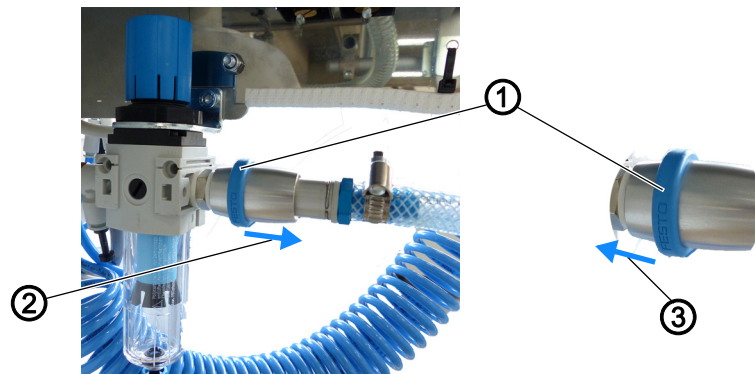

(1) - blue ring

(2) - in arrow direction

(3) - in arrow direction



To disconnect the compressed air supply:

1. Pull the blue ring (1) found under the sewing table on the pneumatic system in arrow direction (2).
- ↳ The compressed air supply is disconnected.
- ↳ You can now move the edge guide ( p. 17) manually.



Important

You need to keep the following in mind: Disconnecting the compressed air supply will return any such units as a connected stacker to their initial position.



To connect the compressed air supply:

2. Slide the blue ring (1) found under the sewing table on the pneumatic system in arrow direction (3).
- ↳ The compressed air supply is connected.

4.5 Disassembling and assembling the fabric sliding plate

WARNING



Risk of injury from sharp and moving parts!

Puncture or crushing possible.

Do not put the machine back into operation until **AFTER** the fabric sliding plate has been assembled.

Fig. 7: Disassembling and assembling the fabric sliding plate (1)

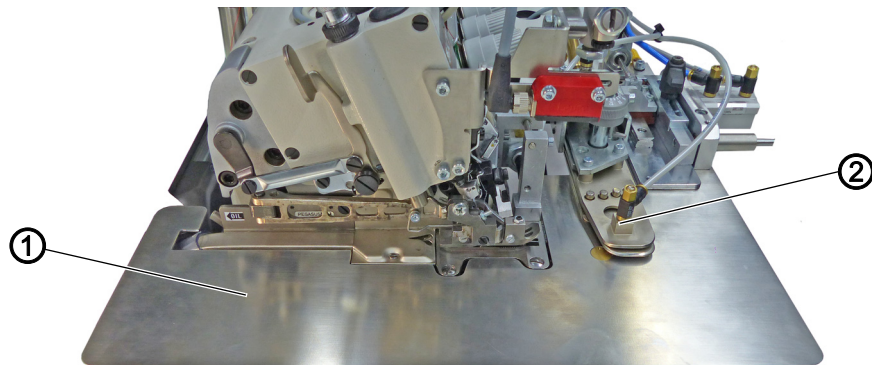

(1) - Fabric sliding plate

(2) - Contour guide

Fig. 8: Disassembling and assembling the fabric sliding plate (2)

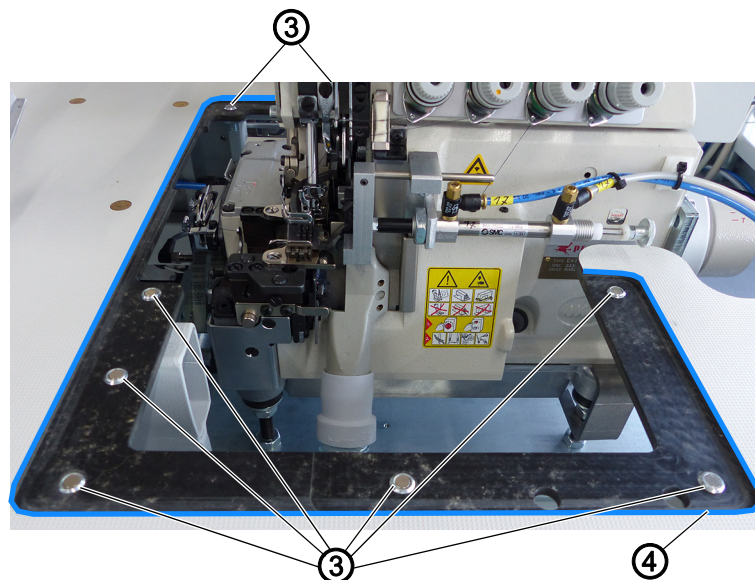

(3) - Magnets

(4) - Tabletop cut-out

Fig. 9: Disassembling and assembling the fabric sliding plate (3)

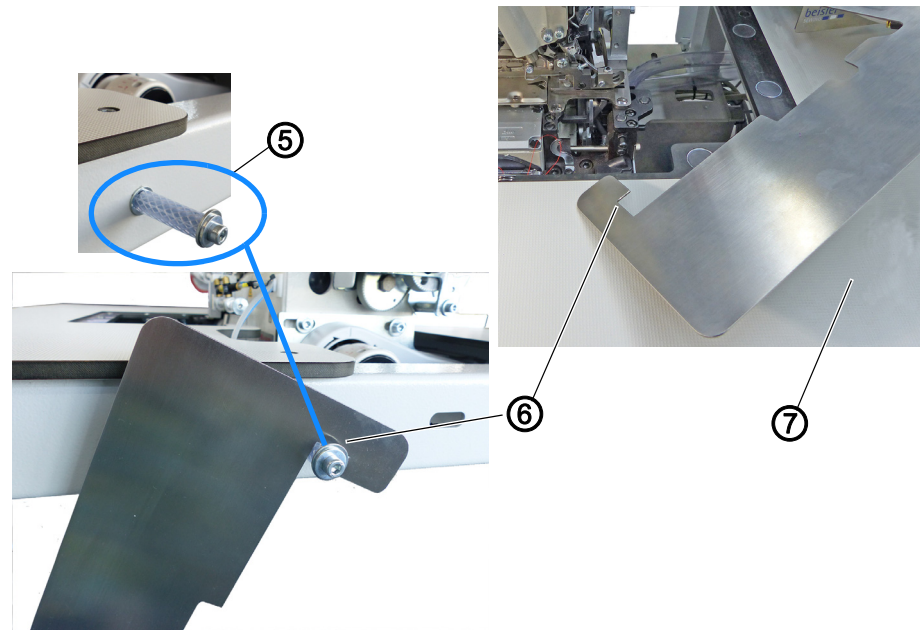

(5) - Bracket

(6) - Notch on the hook

(7) - Sewing table

The fabric sliding plate (1) is held in place in the tabletop cut-out (4) by the magnets (3).

The contour guide (2) is connected to the fabric sliding plate (1) and forms a unit that is removed/placed together.

Disassembling the fabric sliding plate



To disassemble the fabric sliding plate:

1. Carefully pull the contour guide (2) along with the fabric sliding plate (1) up and off the magnets (3).
 2. Swivel the fabric sliding plate (1) aside.
 - 1280: Hang up the fabric sliding plate (1) on the sewing table using the bracket (5) on the side with the notch on the hook (6).
 - 1281: Set down the fabric sliding plate (1) on the delivery table (7).
- ↪ The bottom section of the machine head is now freely accessible (e.g. for threading/cleaning).

Assembling the fabric sliding plate



To assemble the fabric sliding plate:

1. Pick up the fabric sliding plate (1) carefully.
 2. Insert the fabric sliding plate (1) into the tabletop cut-out (4).
- ↪ Make sure it is engaged by the magnets (3).

4.6 Edge guide

WARNING



Risk of injury from sharp and moving parts!

Puncture or crushing possible.

Proceed with utmost caution when adjusting the settings and performing the function test.

4.6.1 Mechanical edge guide

Fig. 10: Mechanical edge guide

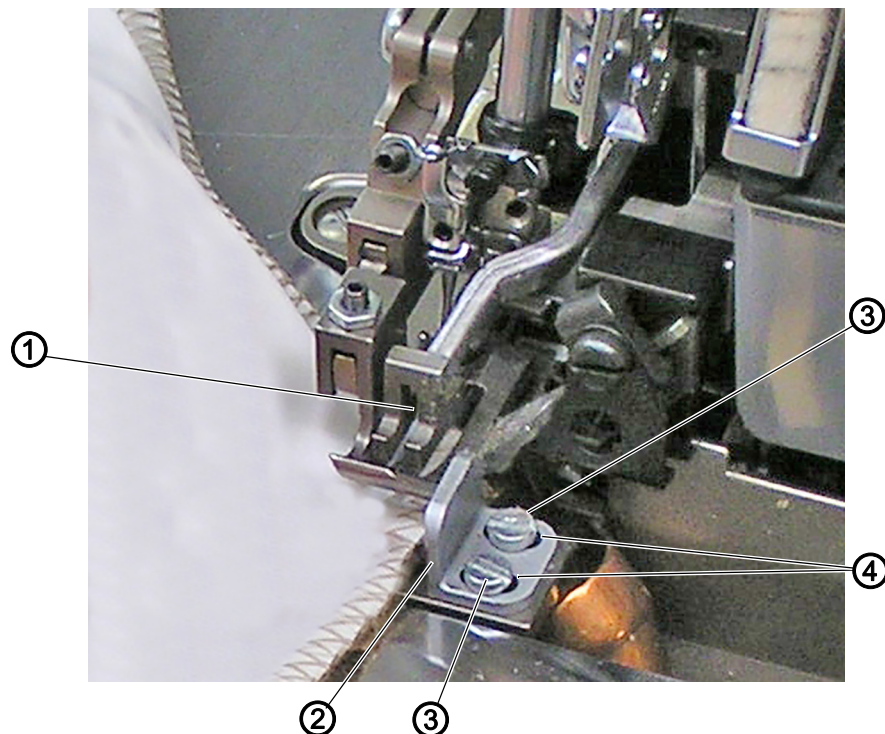

(1) - Sewing foot

(2) - Edge guide

(3) - Screw

(4) - Slotted hole



Proper setting of the mechanical edge guide

The mechanical edge guide (2) must be seated close to the sewing foot (1) to keep the fabric from sliding up between the sewing foot (1) and the mechanical edge guide (2) during sewing.



To adjust the mechanical edge guide:

1. Loosen the 2 screws (3).
2. Move the mechanical edge guide (2) towards the sewing foot in the area of the slotted hole (4).
3. Tighten the 2 screws (3).

4.6.2 Pneumatic edge guide (options 1280 and 1281)

Fig. 11: Pneumatic edge guide (1)

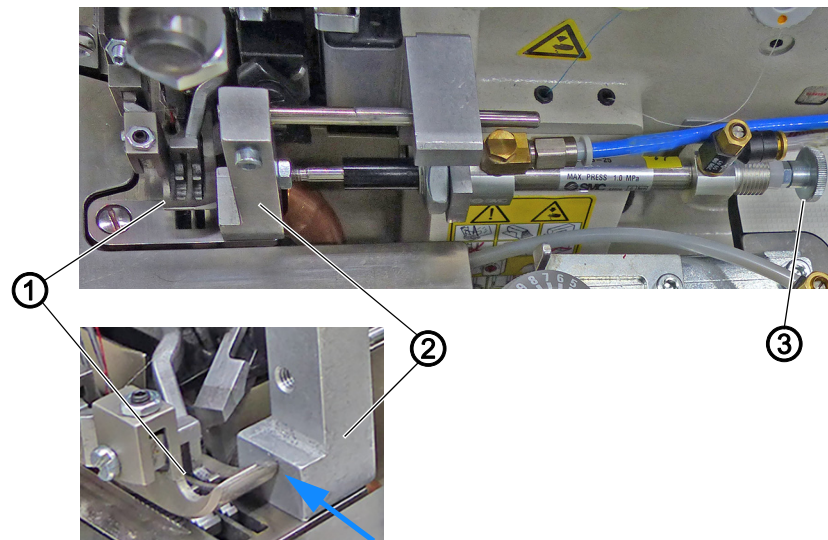

(1) - Sewing foot
(2) - pneumatic edge guide

(3) - Adjusting wheel



Proper setting of the pneumatic edge guide

The pneumatic edge guide (2) must be seated close to the sewing foot (1) to keep the fabric from sliding up between the sewing foot (1) and the sewing material guide (2) during sewing.



To adjust the pneumatic edge guide:

1. Loosen the adjusting wheel (3).
2. Slide the edge guide (2) up close (blue arrow) to the sewing foot (1).
3. Tighten the adjusting wheel (3).

Fig. 12: Sewing material guide (2)

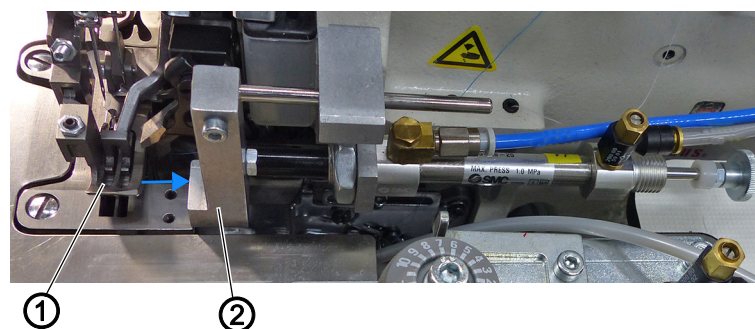

(1) - Sewing foot

(2) - pneumatic edge guide

As the pneumatic edge guide (2) is extendable, it can be used for guiding and trimming the edge of the material. In this setting, the pneumatic edge guide (2) will move away from the sewing foot (1) (blue arrow).



Information

The pneumatic edge guide (optional) makes it possible to trim material overhangs, e.g. pocket bag overhangs, during the sewing process.

4.6.3 Operating the pneumatic edge guide

Fig. 13: Pneumatic edge guide

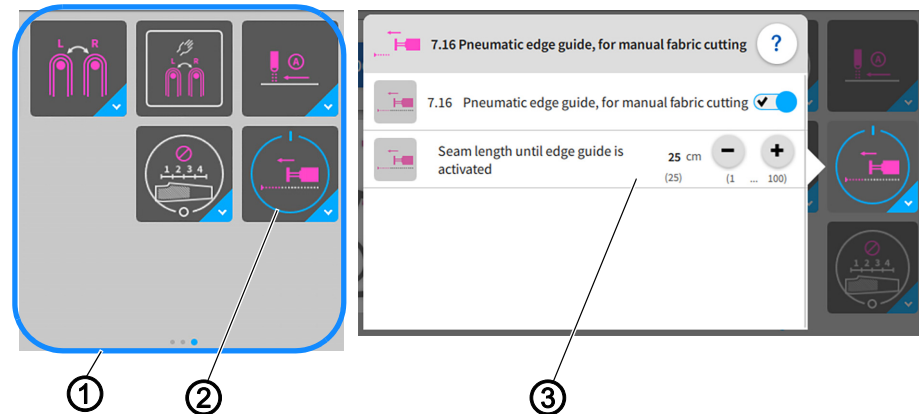

- (1) - Quick Access Icons
 (2) - Pneumatic edge guide button for manual fabric cutting
 (3) - Setting parameters

You can open and change the setting parameters (3) easily using the quick access icons (1) on the control panel found on the main page.



To operate the pneumatic edge guide:

1. Briefly press the button *Pneumatic edge guide for manual fabric cutting* (2) once.
 - ↪ The edge guide switches ON/OFF.
2. Perform a long press on the button *Pneumatic edge guide for manual fabric cutting* (2).
 - ↪ The window for the setting parameters (3) opens.
3. You can change the setting parameters (3) to your requirements.
 - ↪ The new values are adopted automatically.
4. Press briefly outside of the setting parameters (3).
 - ↪ The display returns to the main screen.



Information

You can use the program parameters on the control panel (p. 123, 7.16 *Pneumatic edge guide button for manual fabric cutting*) to program the pneumatic edge guide.

4.7 Contour guide

WARNING



Risk of injury from sharp and moving parts!

Puncture or crushing possible.

Proceed with utmost caution when adjusting the settings and performing the function test.

4.7.1 Adjusting the contour guide

Fig. 14: Adjusting the contour guide (1)

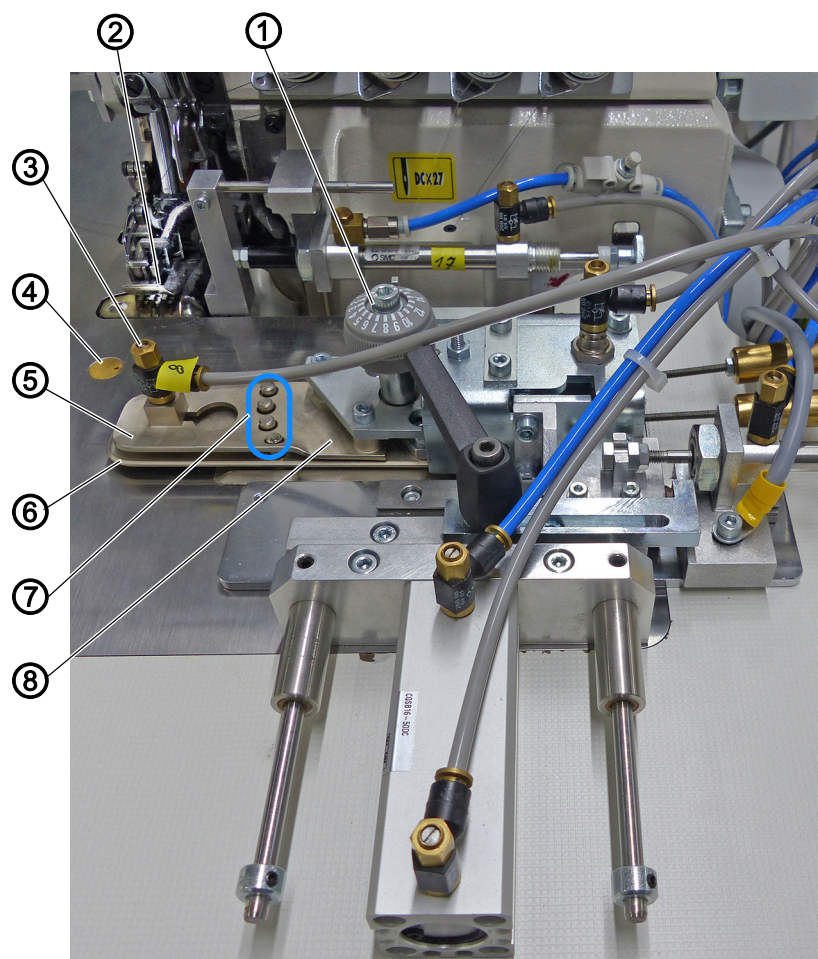

- (1) - Adjusting wheel
- (2) - Sewing foot
- (3) - Blow-on air nozzle
- (4) - Table air nozzle

- (5) - top metal tongue
- (6) - bottom metal tongue
- (7) - Edge guide
- (8) - Contour guide

The contour guide (8) ensures that the sewing material is positioned and guided evenly in front of the sewing head. To match the thickness of the sewing material, the height of the contour guide can be varied by adjusting the opening angle between the top metal tongue (5) and the bottom metal (6) with the adjusting wheel (1). At the same time, the sewing piece

is blown directly towards the edge guide (7) by the table air nozzle (4) and the blow-on air nozzle (3). This provides for perfect control over the seam guidance and a consistent seam width.



Proper setting

The contour guide (8) is supposed to advance such during the sewing process that the contour of the sewing piece is guided reliably to the sewing foot (1) by the edge guide (7) when the sewing piece is stitched down. The sewing material must be able to slide with ease.

Adjusting the opening angle to the thickness of the sewing material



To adjust the height of the opening angle to the thickness of the sewing material:

1. Turn the adjusting wheel (1) to adjust the height of the opening angle.
 - **Position 01:** lowest height
 - **Position 20:** greatest possible height

Travel path of the contour guide

Fig. 15: Adjusting the contour guide (1)

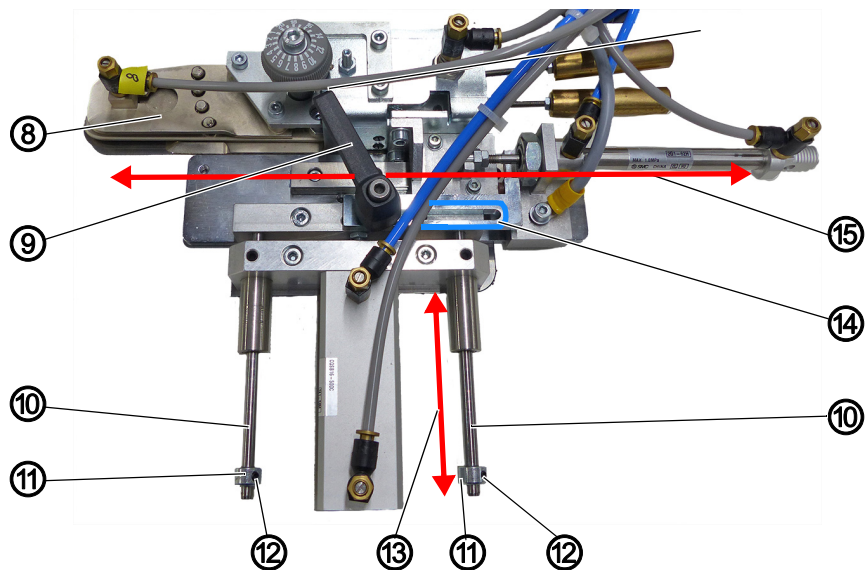

- (8) - Contour guide
- (9) - Clamping lever
- (10) - Linear guide
- (11) - Stop

- (12) - Screw
- (13) - Travel path in sewing direction
- (14) - Slotted hole
- (15) - Travel path crosswise to sewing direction

Adjusting the travel path crosswise to the sewing direction



To adjust the travel path crosswise to the sewing direction (15):

1. Loosen the clamping lever (9).
2. Adjust the contour guide (8) in the area of the slotted hole (14).
- ↳ To limit the travel path of the contour guide (8) crosswise to the sewing direction.
3. Tighten the clamping lever (9).

Adjusting the travel path in sewing direction



To adjust the travel path in sewing direction (13):

1. Loosen the screw (12) in the stop (11).
2. Adjust the contour guide (8) in the area of the linear guide (10).
- ↳ To limit the travel path of the contour guide (8) in sewing direction.
3. Slide and adjust the stop (11) on the linear guide (10).
4. Tighten the screw (12) in the stop (11).

4.7.2 Operating the contour guide

Fig. 16: Operating the contour guide

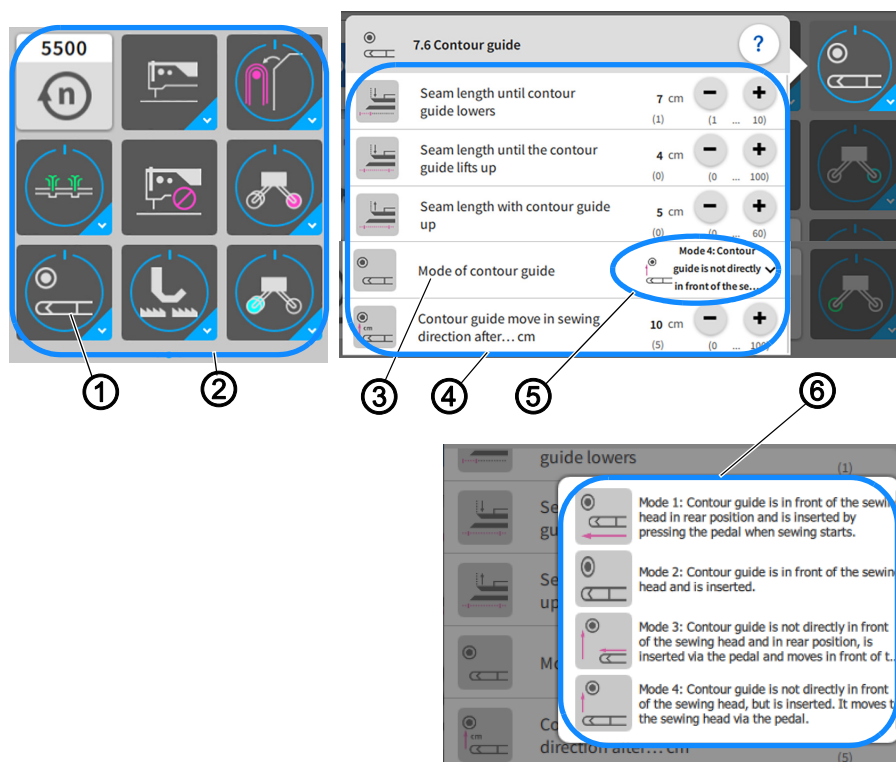

- | | |
|---|-----------------------------------|
| (1) - Button <i>Contour guide</i> | (4) - Setting parameters |
| (2) - Quick access icons | (5) - selected mode |
| (3) - Setting parameters <i>Mode of contour guide</i> | (6) - Modes for the contour guide |

You can open and change the setting parameters (3) and the modes for the contour guide (6) easily using the quick access icons (2) on the control panel found on the main page.



To operate the contour guide:

1. Briefly press the button *Contour guide* (1) once.
- ↳ The contour guide switches ON/OFF.
2. Perform a long press on the button *Contour guide* (1).
- ↳ The window for the setting parameters (4) opens.

3. You can change the setting parameters (4) to your requirements.
 - ↪ The new values are adopted automatically.
4. Call up the submenu in the setting parameter *Mode of contour guide* (3).
 - ↪ The modes for the contour guide (6) are displayed.
5. Press the desired *Mode 1 to Mode 4*.
 - ↪ The selected *Mode 1* (5) appears in the setting parameter (3).
6. Press briefly outside of the setting parameters (4).
 - ↪ The display returns to the main screen.



Information

You can use the program parameters on the control panel (📖 p. 123, 7.6 *Contour guide*) to program the contour guide.

4.8 Knee button (option for 1280)

Fig. 17: Knee button

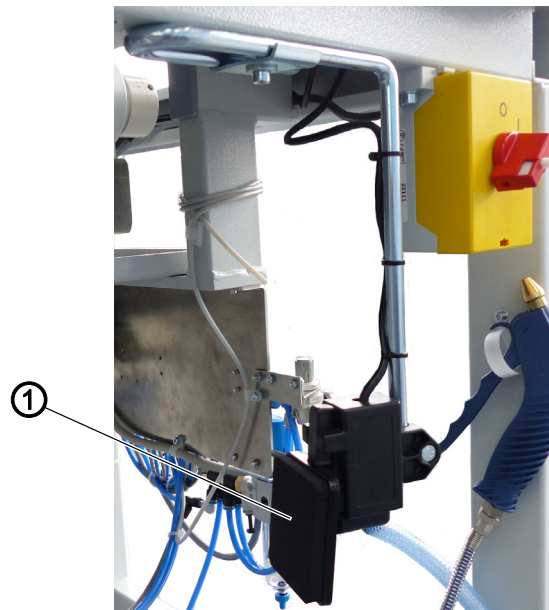

(1) - Knee button

You can use the knee button (1) to retract/extend the contour guide during the sewing process.



To operate the knee button:

1. Press the knee button (1) with your knee as needed during the sewing process.
 - ↪ The contour guide is retracted.

2. Press the knee button (1) again.
- ↪ The contour guide is extended.

4.9 Differential feed

WARNING



Risk of injury from sharp and moving parts!

Puncture or crushing possible.

Proceed with utmost caution when adjusting the settings and performing the function test.

The differential feed provides for a perfect fit by partially incorporating additional fullness in the top or bottom layer of fabric.

The distribution of additional fullness is grouped into fullness distribution controlled by the stepper motor, automatic fullness distribution by pneumatically controlled top and bottom feed and fullness distribution by a mechanically adjusted differential setting for top and bottom feed.

4.9.1 Fullness distribution controlled by the stepper motor (option)

Fig. 18: Fullness distribution controlled by the stepper motor (1)

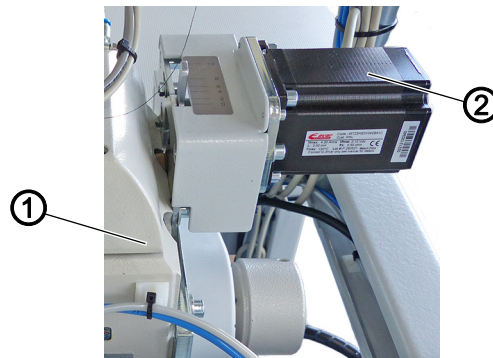

(1) - Sewing head

(2) - Stepper motor for differential top feed

The stepper motor for the differential top feed (2) is a positioning drive and located above the sewing table on the right side of the sewing head (1).

Fig. 19: Fullness distribution controlled by the stepper motor (2)

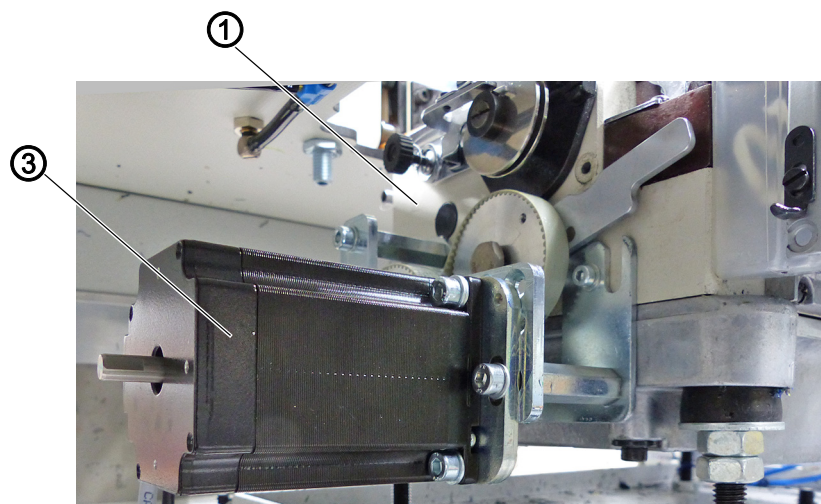

(1) - Sewing head

(2) - Stepper motor for differential bottom feed
(3) - Stepper motor for differential bottom feed

The stepper motor for the differential bottom feed (3) is located under the sewing table on the left side of the sewing head (1).

Controlled by the stepper motor, the fullness distribution can be programmed and allows for a programmed retrieval of additional fullness in the top and bottom layer of fabric.

The entire seam can be divided in up to 5 freely selectable seam sections. Parameters can be set individually for each section. The activation of additional fullness always applies to the selected section to which you wish to add fullness.

A distinction is made between:

- Differential bottom feed
 - Setting of program parameters
(📖 p. 123, 7.3 *Differential bottom feed*)
 - Programming the stepper-motor-controlled differential bottom feed (📖 p. 140)
- Differential top feed
 - Setting of program parameters
(📖 p. 123, 7.19 *Differential top feed*)
 - Programming the stepper-motor-controlled differential top feed (📖 p. 145)

You can select additional fullness “*Fullness +*” to incorporate additional fullness in all 5 sections of the seam. “*Fullness +*” is used when fabric is changed in the same program sequence, but with slightly more/less fullness across all activated fullness sections of the seam.

Fig. 20: Fullness distribution controlled by the stepper motor (3)

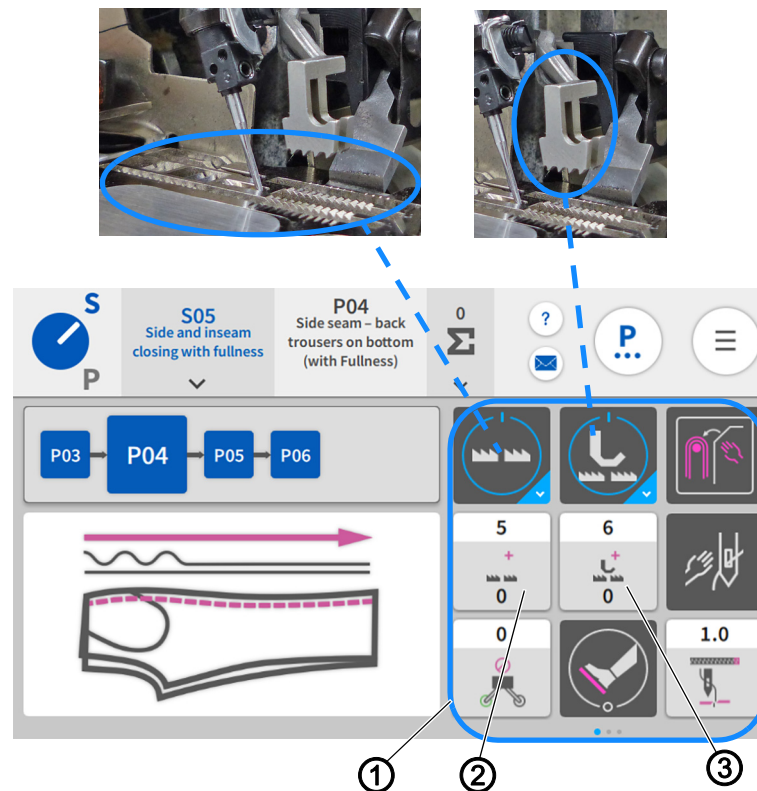

- (1) - Quick Access Icons
 (2) - Button additional fullness for the differential bottom feed
 (3) - Button additional fullness for the differential top feed

On the main page of the control panel (📖 p. 72), you can easily configure the buttons:

- additional fullness for the differential bottom feed (2)
 (📖 p. 123, 7.3 Differential bottom feed)
- additional fullness for the differential top feed (3)
 (📖 p. 123, 7.19 Differential top feed)

as quick access icons (1) (📖 p. 157).

Fig. 21: Fullness distribution controlled by the stepper motor (3)

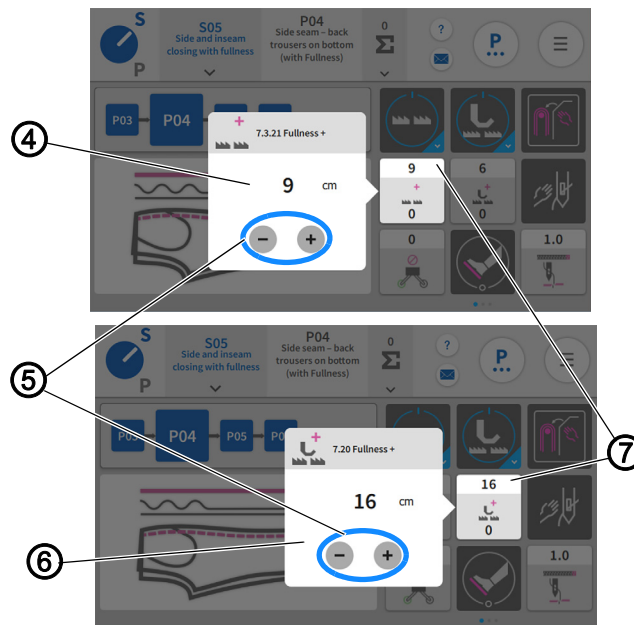

- (4) - Value range of additional fullness for differential bottom feed
- (5) - Button minus/plus
- (6) - Window of additional fullness for differential top feed
- (7) - Bar



To enter the value for additional fullness + :

1. Briefly press the button *additional fullness for the differential bottom feed* (2)/*additional fullness for the differential top feed* (3).
- ↳ The window for the value range of additional fullness for the differential bottom feed (4)/the window for the value range of additional fullness for the differential top feed (6) opens.
2. Use the *minus/plus* (5) button to adjust the value.
3. Press in a blank area.
- ↳ The value is adopted and displayed to the user in the upper bar (7).

Fig. 22: Fullness distribution controlled by the stepper motor (4)

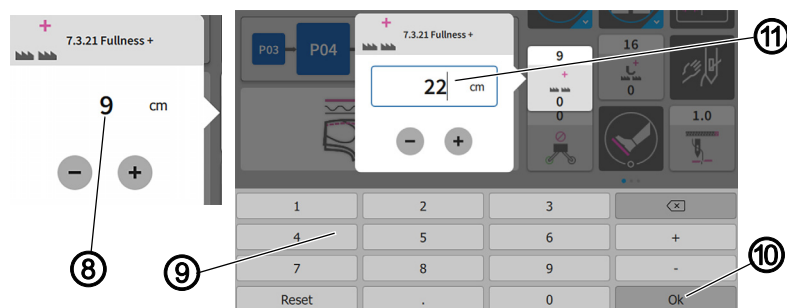

- (8) - Number
- (9) - Keyboard
- (10) - Ok
- (11) - new value



Another option is to enter the value for Fullness + manually:

1. Briefly press the button *additional fullness for the differential bottom feed (2)*/*additional fullness for the differential top feed (3)*.
 - ↪ The window for the value range of additional fullness for the differential bottom feed (4)/the window for the value range of additional fullness for the differential top feed (6) opens.
2. Tap the number (8) directly in the window.
 - ↪ The keyboard (9) opens.
3. Use the keyboard (9) to enter the new value (11).
4. Confirm with Ok (10).
 - ↪ The display returns to the previous page.

4.9.2 Pneumatically controlled fullness distribution (option)

Fig. 23: Pneumatically controlled fullness distribution (1)

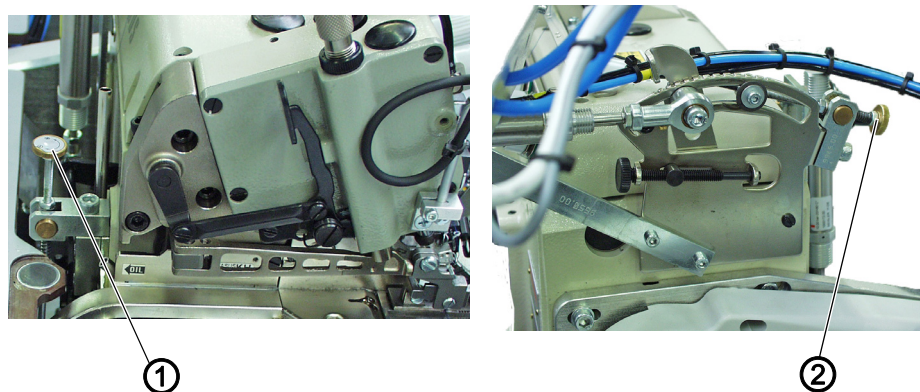

(1) - Adjusting wheel bottom feed

(2) - Adjusting wheel top feed



To adjust the fullness:

1. Turn the adjusting wheel bottom feed (1).
 - **Increased fullness:** Turn the adjusting wheel bottom (1) further into the plus range.
 - **Reduced fullness:** Turn the adjusting wheel (1) further into the minus range.
2. Turn the adjusting wheel top feed (2).
 - **Increased fullness:** Turn the adjusting wheel top feed (2) further into the plus range.
 - **Reduced fullness:** Turn the adjusting wheel top feed (2) further into the minus range.

The automatic fullness distribution by a pneumatically controlled differential top and bottom feed allows for a programmed retrieval of additional fullness in the top and bottom layer of fabric.

A distinction is made between a mechanically set fullness and a pneumatically adjustable fullness that can be programmed.

- Differential bottom feed
 - Setting of program parameters (📖 p. 123, 7.3 *Differential bottom feed*)
 - Programming of the pneumatic differential bottom feed (📖 p. 138)
- Differential top feed
 - Setting of program parameters (📖 p. 123, 7.19 *Differential top feed*)
 - Programming of the pneumatic differential top feed (📖 p. 143)

The entire seam can be divided in up to 5 freely selectable seam sections. Parameters can be set individually for each section. The activation of additional fullness always applies to the selected section for which fullness had been set mechanically beforehand.

4.10 Light barrier



Important

Adjustments to the light barrier are made with the sewing unit switched on.

WARNING



Risk of injury from sharp and moving parts!

Puncture or crushing possible.

Proceed with utmost caution when adjusting the settings and performing the function test.

4.10.1 Aligning the light barrier

Fig. 24: Aligning the light barrier

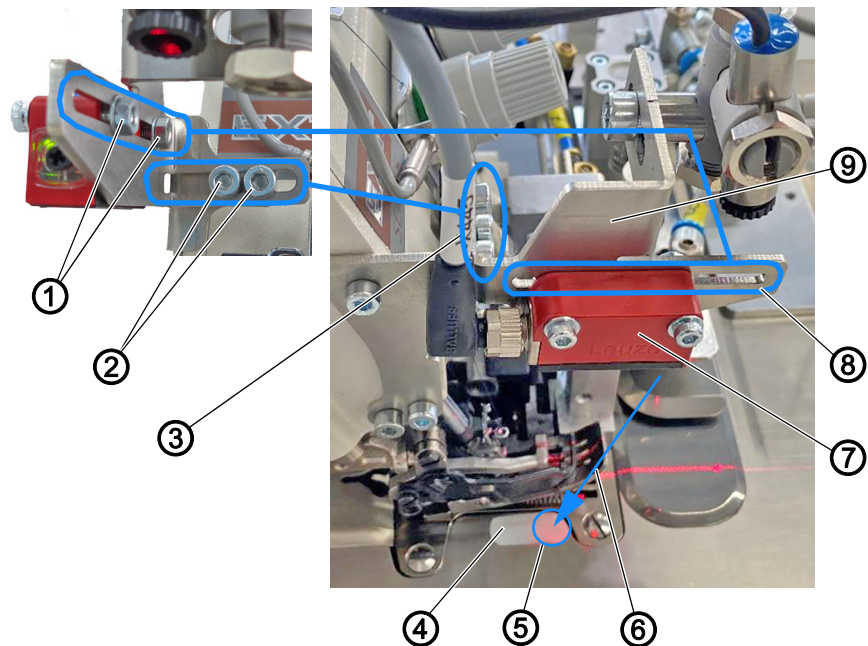

- | | |
|--|---------------------|
| (1) - Screw | (6) - Light beam |
| (2) - Screw | (7) - Light barrier |
| (3) - Slotted hole | (8) - Slotted hole |
| (4) - Reflecting foil | (9) - Holder |
| (5) - In the front part of the reflecting foil,
centrically from the circle | |



Proper setting

Set the light barrier (7) such that it is positioned in front of the needle at the height of the edge trimmer knife. The alignment of the light beam (6) must be such that it hits the reflecting foil (4) concentrically from the circle (5) in the front part of the reflecting foil.

- Automatic sewing start later: move the light barrier (7) in the slotted hole (8) with the sewing direction.
- Automatic sewing start earlier: move light barrier (7) in the slotted hole (8) against the sewing direction.



To align the light barrier:

1. To be on the safe side, activate threading mode (📖 p. 78).
2. Loosen the screws (1).
3. Move the light barrier (7) in the area of the slotted hole (8) with the sewing direction.
4. Tighten the screws (1).
5. Loosen the screw (2).
6. Move the holder (9) with the light barrier (7) in the area of the slotted hole (3).
7. Tighten the screw (2).

4.10.2 Adjusting the light barrier intensity

Fig. 25: Adjusting the light barrier intensity

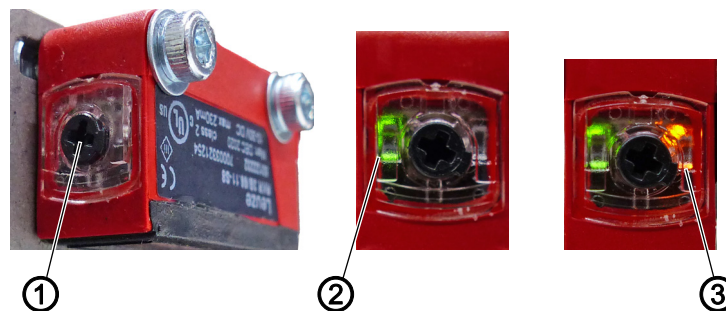

(1) - Potentiometer
(2) - LED

(3) - LED



Proper setting

The LED (3) on the potentiometer (1) lights up orange permanently.



To adjust the intensity of the light barrier:

1. Turn the potentiometer (1) counterclockwise as far as it will go.
 - ↪ The LED (2) lights up green.
 - Green = light barrier has power and is active.
2. Turn the potentiometer (1) clockwise until the LED (3) starts flashing.
3. Continue to turn the potentiometer (1) until the LED (3) is lit orange reliably and permanently.
 - ↪ The process is now complete.

**Information**

If the LED is not lit, you should clean, readjust or replace the light barrier.

4.11 Laser marking lamp**4.11.1 Position of laser marking lamp**

Fig. 26: Position of laser marking lamp

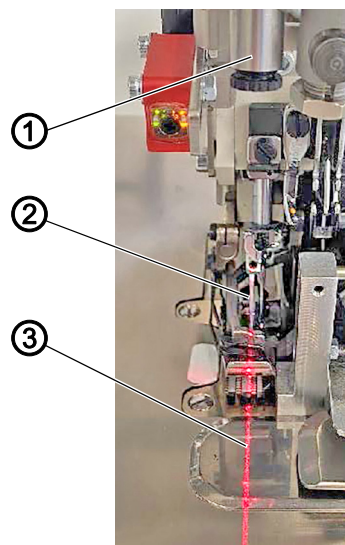

(1) - Laser marking lamp
(2) - left needle

(3) - Laser beam

The laser marking lamp (1) is used to indicate and check the seam course. The laser beam (3) shows the position of the seam. Helpful for wing pockets or side seam pockets in the area of the pocket opening.

**Proper setting**

The laser marking lamp (1) must be set such that the laser beam (3) is positioned on the left needle (2) as viewed with the direction of sewing.

**Information**

You must use the program parameters on the control panel ( p. 123, 7.22 *Laser marking lamp*) to activate the laser marking lamp (1) beforehand.

4.12 Thread monitor

Fig. 27: Thread monitor

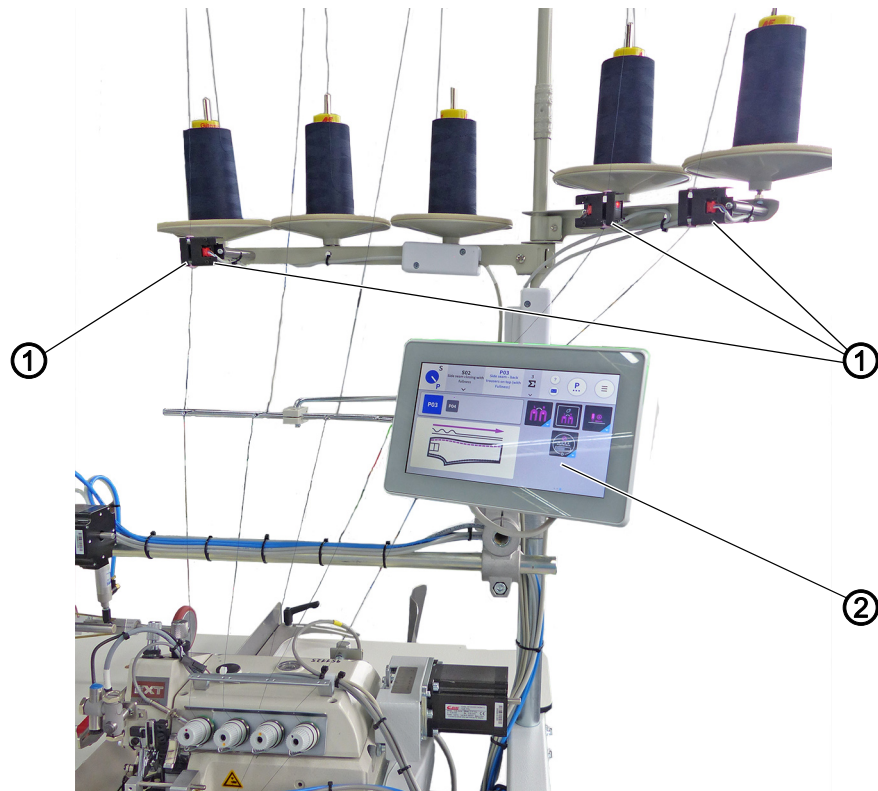

(1) - Thread monitor

(2) - Control panel

You can use 1, 2 or the maximum of 3 thread monitors (1).

If thread breakage occurs, a warning message will immediately be shown on the control panel (2) reading *Thread breakage on monitor 1/2/3* (📖 p. 201). The sewing program continues until completion before the machine stops to allow you to perform the threading procedure.



To use the thread monitor:

1. Confirm the warning *Thread breakage on monitor 1/2/3* on the control panel (2) with a press of *OK*.
- ↳ The display on the screen automatically switches to threading mode (📖 p. 78).
2. Re-thread the thread (📖 p. 17).
3. Exit threading mode.
4. Start a new sewing process.



Information

You can use global parameters on the control panel (📖 p. 98, 1.3.5 *Thread monitor*) to program the thread monitors.

4.13 Stacker

WARNING



Risk of injury from moving parts!

Crushing possible.

While stacking is in progress, DO NOT reach into the working area of the flip/clamping/alternating stacker.

4.13.1 Operating the flip stacker

Fig. 28: Operating the flip stacker (1)

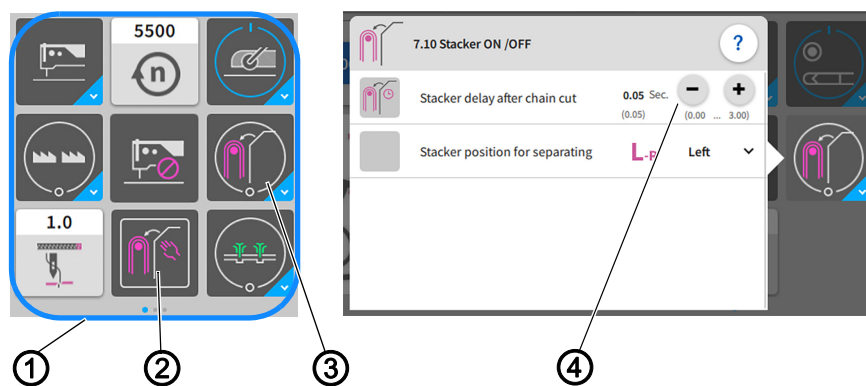

- (1) - Quick Access Icons
- (2) - Button Trigger stacking process manually
- (3) - Button Stacker
- (4) - Setting parameters

Fig. 29: Operating the flip stacker (2)

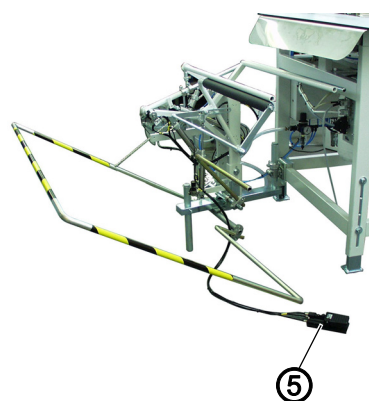

- (5) - Pedal for opening the clamping stacker

The finished sewn products are stacked on the flip stacker. You can open and change the setting parameters (4) easily using the quick access icons (1) on the control panel found on the main page.

Stacking the sewing material



To stack the sewing material:

1. Press the button *Trigger stacking process manually* (2).

↳ The stacking process is executed once.

2. Briefly press the button *Stacker* (3) once.

↳ The stacker switches ON/OFF.

↳ The stacking process is executed/not executed.



3. Perform a long press on the button *Stacker* (3).

↳ The window for the setting parameters (4) opens.

4. You can change the setting parameters (4) to your requirements.

↳ The new values are adopted automatically.

Removing stacked pieces



To remove stacked pieces:

1. Press the pedal for opening the clamping stacker (5) and keep it there.

↳ The flip stacker opens.

2. Remove the stacked pieces.

4.13.2 Operating the clamping stacker

Fig. 30: Operating the clamping stacker (1)

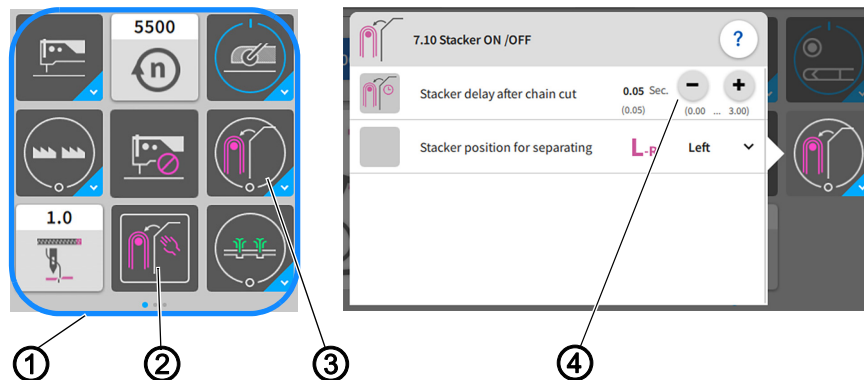

(1) - Quick Access Icons
(2) - Button *Trigger stacking process manually*

(3) - Button *Stacker*
(4) - Setting parameters

Fig. 31: Operating the clamping stacker (2)

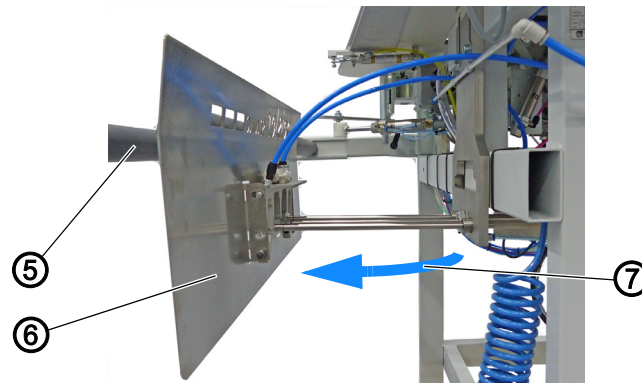

(5) - Stacker tray
 (6) - Clamping stacker

(7) - Arrow direction

The clamping stacker (6) is used to stack the finished sewn products during the ongoing sewing process. By default, the clamping stacker (6) is equipped with two arms for the stacker tray (5). A stacker with an extension for the stacker tray is available for large/long sewing material (📖 p. 193).

You can open and change the setting parameters (4) easily using the quick access icons (1) on the control panel found on the main page.

Stacking the sewing material



To stack the sewing material:

1. Press the button *Trigger stacking process manually* (2).
 ↳ The stacking process is executed once.
2. Briefly press the button *Stacker* (3) once.
 ↳ The stacker switches ON/OFF.
 ↳ The stacking process is executed/not executed.

Stacking process:

- Once the sewing material is fully sewn and has reached the level of the clamping stacker (6), the clamping stacker (6) moves towards the stacker tray (5) in arrow direction (7).
 - The sewing material is deposited automatically on the stacker tray (5).
3. Perform a long press on the button *Parameters for the stacking process* (1).
 ↳ The window for the setting parameters opens.
 4. You can change the setting parameters (5) to your requirements.
 ↳ The new values are adopted automatically.
 ↳ You can remove the sewing material directly from the stacker tray.



Information

You can use the program parameters on the control panel (📖 p. 123, 7.10 *Stacker*) to program the stacker.

4.13.3 Operating the alternating stacker

Fig. 32: Operating the alternating stacker (1)

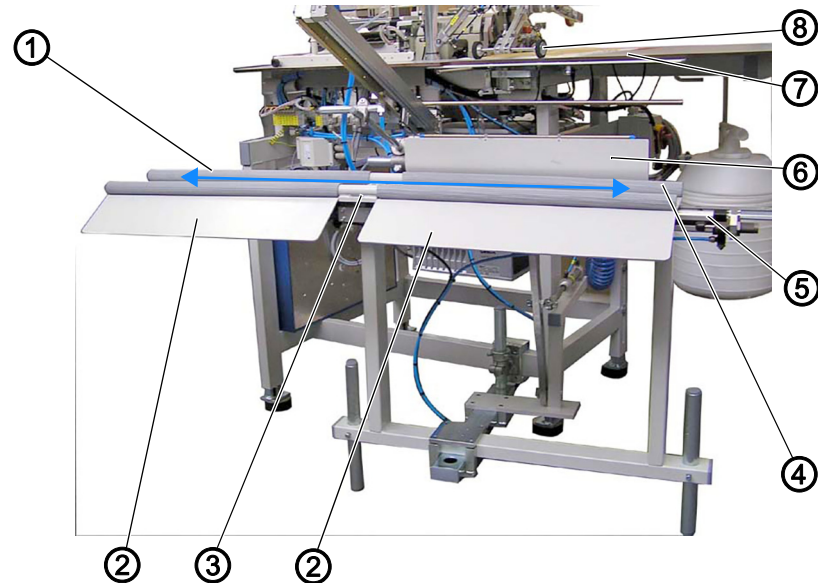

- | | |
|---------------------------|-----------------------|
| (1) - Alternating stacker | (5) - Track |
| (2) - one site/position | (6) - Stacking clamp |
| (3) - Delivery table | (7) - Sewing table |
| (4) - Sliding edge | (8) - Roll-out device |

On the alternating stacker (1), the finished sewing pieces are stacked separately - either sorted by right and left sewing pieces or for large storage of several bundles. For this purpose, the alternating stacker (1) moves back and forth in arrow direction along the track (5) on its delivery table (3).

The delivery table (3) will change positions in arrow direction depending on the programming:

- after every seam
- after every sequence
- remains in one position (2) (inactive)

As soon as the sewing piece's center of gravity is shifted over the edge of the sewing table (7) by the roll-out device (8), the stacking clamp (6) extends and fixes the sewing piece in place at the sliding edge (4) of the delivery table (3). Additional blowing nozzles on the stacking clamp (6) ensure that the sewing pieces are cleanly deposited via the delivery table (3) of the alternating stacker (1).

Fig. 33: Operating the alternating stacker (2)

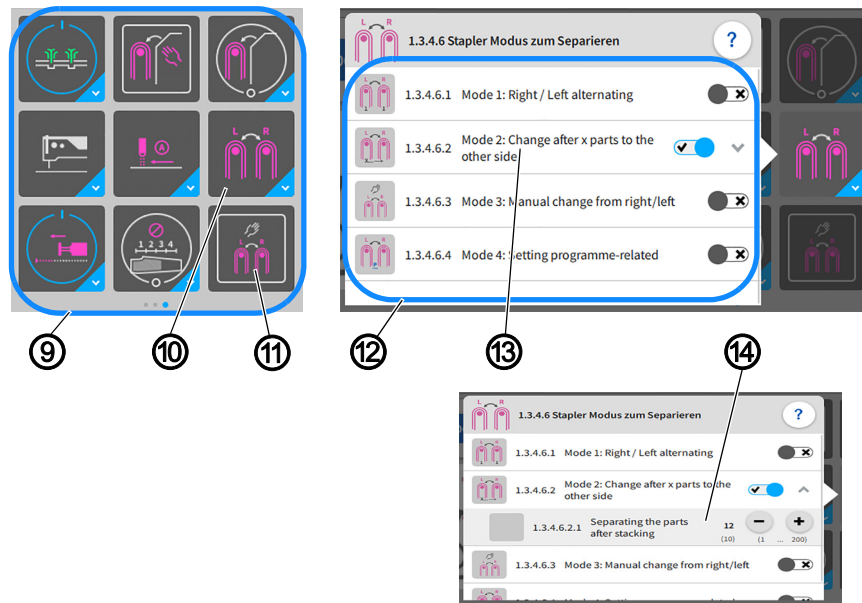

- (9) - Quick Access Icons
 (10) - Button Stacker mode for separating
 (11) - Button Manual change between right/left
 (12) - Stacker modes for separating
 (13) - Mode 2
 (14) - Setting parameters

You can open and change the stacker modes for separating (12) easily using the quick access icons (9) on the control panel found on the main page.

Separating sewing material



To separate the sewing material:

1. Press the button *Manual change between right/left* (11).
 ↳ The manual change between the position right/left is carried out once.
2. Press the button *Stacker mode for separating* (10).
 ↳ The window for the stacker modes for separating (12) opens.
3. The stacker modes for separating (12) can be set to active/inactive as needed.
 ↳ The new settings are adopted automatically.
4. In Mode 2 (13), press into the submenu *Change after x parts to the other side*.
 ↳ The window containing the setting parameters (14) *Separating the parts after stacking* opens.
5. You can adjust as needed in the setting parameter (14) the number of parts after which the separation of the parts is supposed to take place.
6. The new number is adopted automatically.
7. The sewing material can be removed directly from the delivery table (3) of the alternating stacker (1).



Information

You can use the program parameters on the control panel (📖 p. 123, 7.10 *Stacker*) to program the stacker.

4.14 Air nozzles

4.14.1 Adjusting the air nozzles 1280 in the tabletop

Fig. 34: Adjusting the air nozzles 1280 in the tabletop (1)

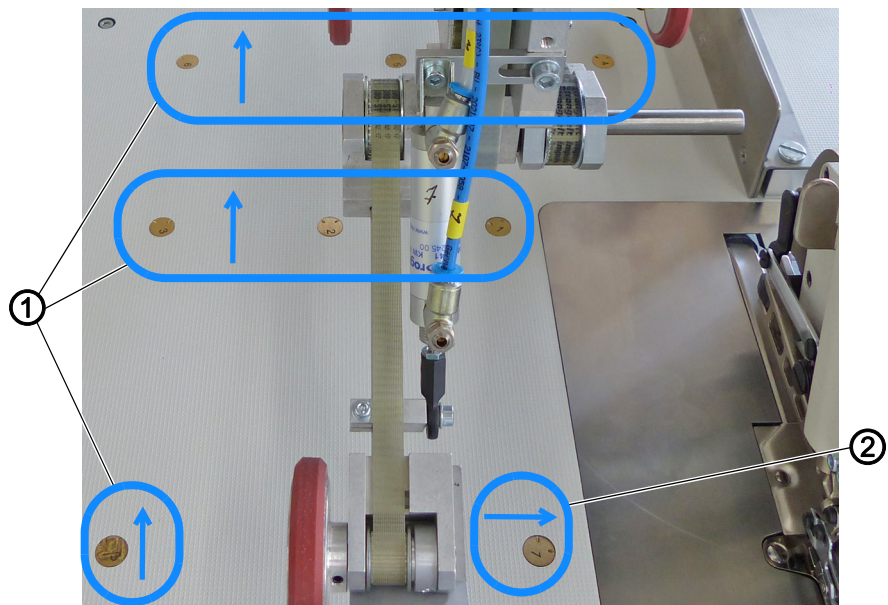

(1) - Air nozzles facing the stacker

(2) - Air nozzles facing the sewing head

Fig. 35:

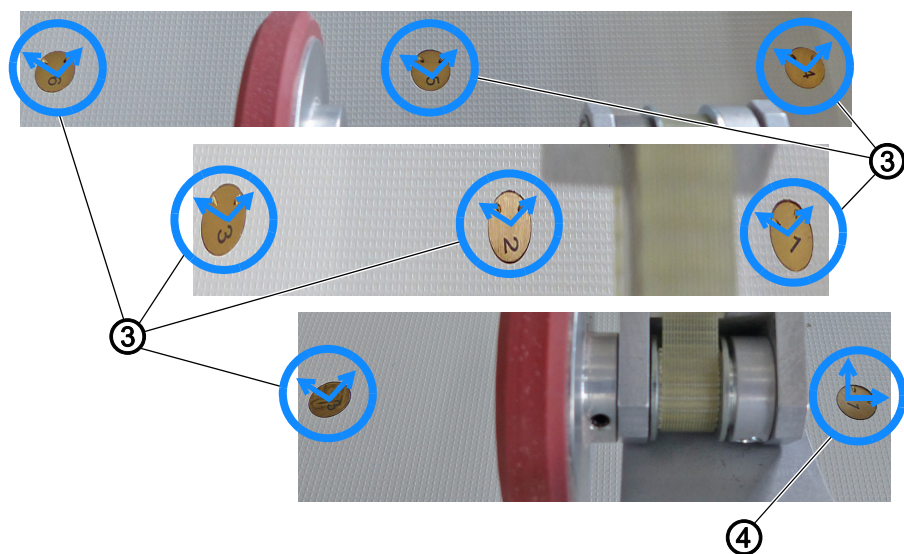

(3) - Alignment: approx. 11:00 and 01:00 o'clock

(4) - Alignment: approx. 12:00 and 03:00 o'clock



Proper setting

- The air nozzles facing the stacker (1)
 - ↪ Alignment: approx. 11:00 and 01:00 o'clock (3) supports transport to the stacker.
- The air nozzles facing the sewing head (2)
 - ↪ Alignment: approx. 12:00 and 03:00 o'clock (4) supports the feed of material to the sewing head during the sewing process.

4.14.2 Adjusting the air nozzles 1281 in the tabletop

Fig. 36: Adjusting the air nozzles 1281 in the tabletop (1)

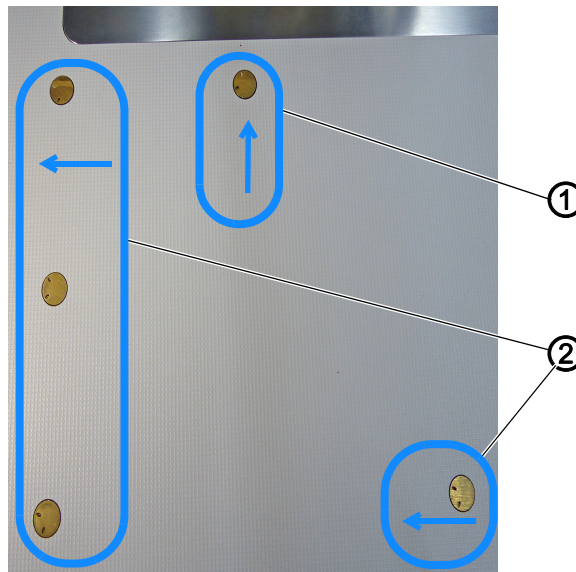

(1) - Air nozzles facing the sewing head (2) - Air nozzles facing the stacker

Fig. 37: Adjusting the air nozzles in the tabletop (2)

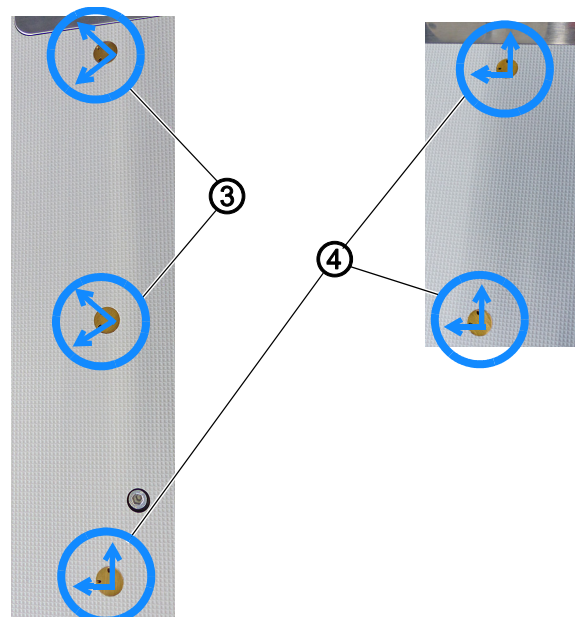

(3) - Alignment: approx. 08:00 and 10:00 o'clock (4) - Alignment: approx. 12:00 and 09:00 o'clock



Proper setting

- The air nozzles facing the stacker (1)
 - ↪ Alignment: approx. 08:00 and 10:00 o'clock (3) supports transport to the stacker.
- The air nozzles facing the sewing head (2)
 - ↪ Alignment: approx. 12:00 and 09:00 o'clock (4) supports the feed of material to the sewing head during the sewing process.

4.14.3 Adjusting the air supply

Fig. 38: Adjusting the air supply

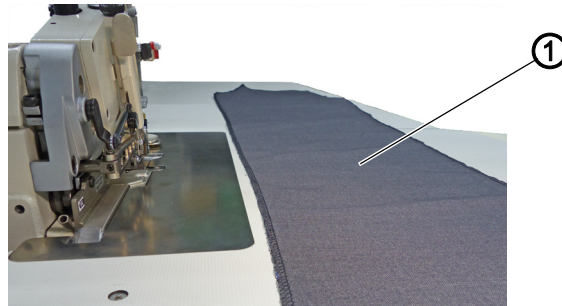

(1) - Sewing material



Proper setting

The air supply to the air nozzles must be adjusted to the corresponding thickness of the sewing material.



To adjust the air supply to the air nozzles:

1. Place the sewing material (1) on the sewing table above the air nozzles.
 2. Log in as a *Default Technician* (📖 p. 111) on the control panel.
 3. Test the air supply using the *Input/Output Test* (📖 p. 91) menu item.
- ↪ The air should slightly lift the sewing material, allowing you to push the sewing material towards the sewing head/stacker using merely 2 fingers/almost automatically.



Information

If the sewing material is **not** pushed towards the stacker/sewing head, the air nozzles in the tabletop need to be adjusted (📖 p. 45) accordingly.

4.14.4 Adjusting the air supply intensity

The air nozzles in the tabletop help the sewing material to be fed properly during the ongoing sewing process. Lifting and advancing the sewing material towards the stacker reduces the risk of the sewing material becoming caught.

Adjusting the air supply using the throttle valve (1280)

Fig. 39: Adjusting the air supply intensity (1)

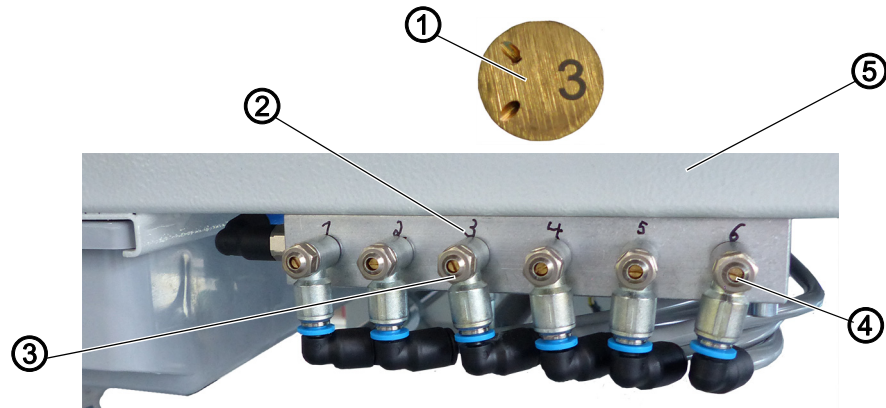

(1) - numbered air nozzle
 (2) - Number

(3) - Throttle valve
 (4) - Screw
 (5) - Tabletop

Located under the tabletop (5) is a distributor block with multiple throttle valves. Each throttle valve (3) is marked with a number (2) that matches the corresponding numbered air nozzle (1) in the tabletop (5). The numbered table air nozzle (1) is adjusted individually or as part of a group.



To adjust the air supply intensity using the throttle valve:

1. Loosen the screw (4).
2. Turn the throttle valve (3).
 - **Blowing air more intense:** Turn clockwise
 - **Blowing air less intense:** Turn counterclockwise
3. Tighten the screw (4).



Information

You can use the program parameters on the control panel (📖 p. 123, 7.4 Table blowing) to program the air nozzles.

Adjusting the air supply using the adjusting wheel (1281)

Fig. 40: Adjusting the air supply intensity (2)

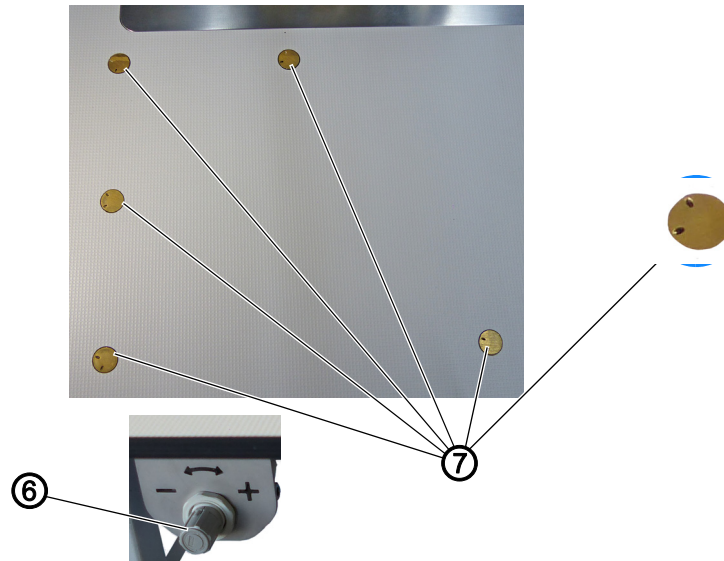

(6) - Adjusting wheel

(7) - Air nozzles



To adjust the air supply intensity using the adjusting wheel:

1. Turn the adjusting wheel (6).
 - **Blowing air more intense:** turn towards +
 - **Blowing air less intense:** turn towards -



Information

You can use the program parameters on the control panel ( p. 123, 7.4 Table blowing) to program the air nozzles (7).

Adjusting the air supply using the throttle valve in the fabric sliding plate

Fig. 41: Adjusting the air supply intensity (3)

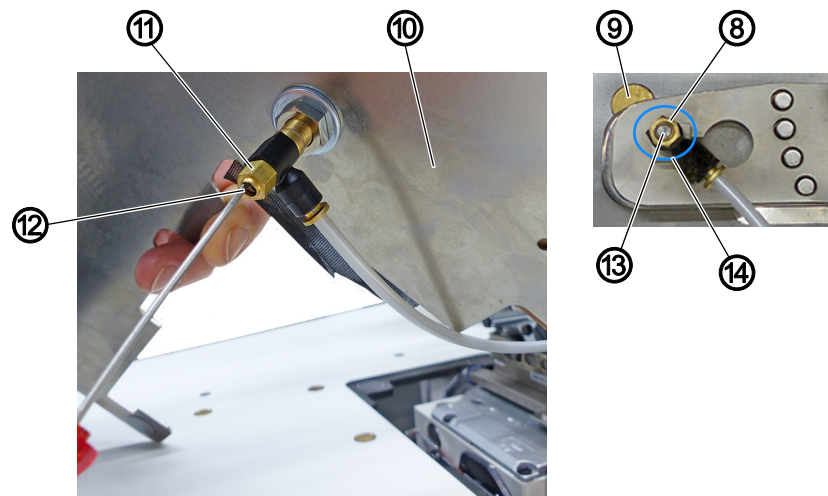

(8) - Throttle valve
 (9) - Table air nozzle
 (10) - Fabric sliding plate

(11) - Throttle valve
 (12) - Screw
 (13) - Screw
 (14) - Air nozzle in the contour guide

The table air nozzle (9) in the fabric sliding plate is adjusted separately via the throttle valve (11) found under the fabric sliding plate (10). The air nozzle in the contour guide (14) is adjusted to match this setting via the throttle valve (8).



To adjust the air supply intensity using the throttle valve under the fabric sliding plate:

1. Disassemble the fabric sliding plate (10).
2. Loosen the screw (12).
3. Turn the throttle valve (11).
 - **Blowing air more intense:** Turn clockwise
 - **Blowing air less intense:** Turn counterclockwise
4. Tighten the screw (12).



To adjust the air supply intensity using the throttle valve in the contour guide:

1. Loosen the screw (13).
2. Turn the throttle valve (8).
 - **Blowing air more intense:** Turn clockwise
 - **Blowing air less intense:** Turn counterclockwise
3. Tighten the screw (13).

4.15 Transport station

WARNING



Risk of injury from moving parts!

Crushing possible.

While transport is in progress, DO NOT reach into the working area of the transport station.

Fig. 42: Transport station (1)

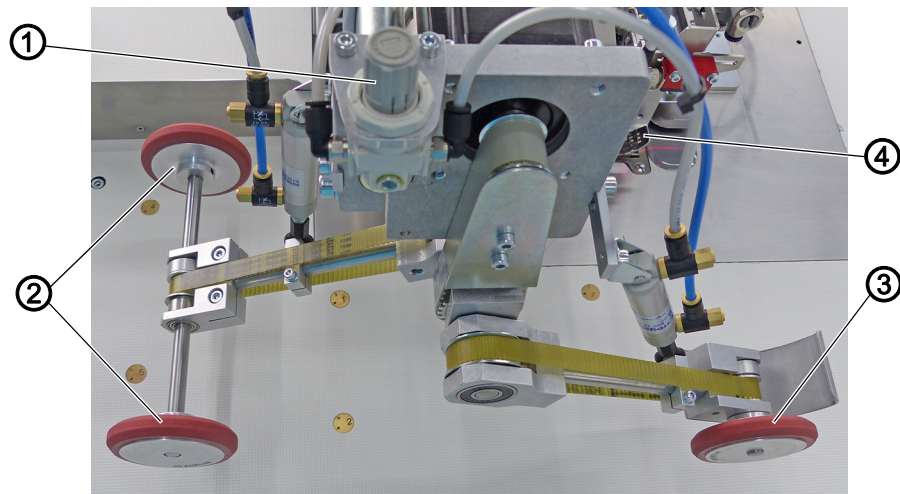

- (1) - Pressure setting of the transport roller (3) - Puller
(2) - Roll-out device (4) - Sewing foot

The transport station is composed of the puller (3), which is attached at the front level with the sewing foot (4), and the roll-out device (2), which is attached at the rear. These are brought into position for their use when lowering.

The transport roller of the puller (3) exerts pressure on the sewing material from the top and can be regulated with the pressure setting of the transport roller (1). The puller (3) can thus be adjusted perfectly to the thickness of the sewing material, ensuring that the sewing material is guided properly during the sewing process. The sewing material is fed to the roll-out device (2) along the sewing head on the side. In addition, the puller prevents material blockage.

The roll-out device (2) is used to safely position the sewing material for chain cutting and for subsequently rolling it out into the stacker. This ensures for short pieces that the stacker will be able to clamp the material thanks to the extended roll-out position.

Fig. 43: Transport station (2)

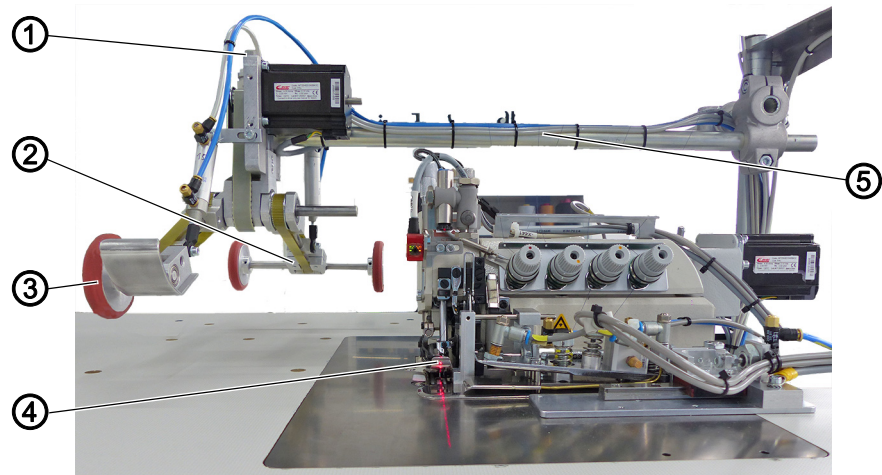

- (1) - Adjusting wheel
- (2) - Roll-out device
- (3) - Puller

- (4) - Sewing foot
- (5) - fixed rods

Transport station with fixed rods (5) for sewing unit 1280-7.

Fig. 44: Transport station (3)

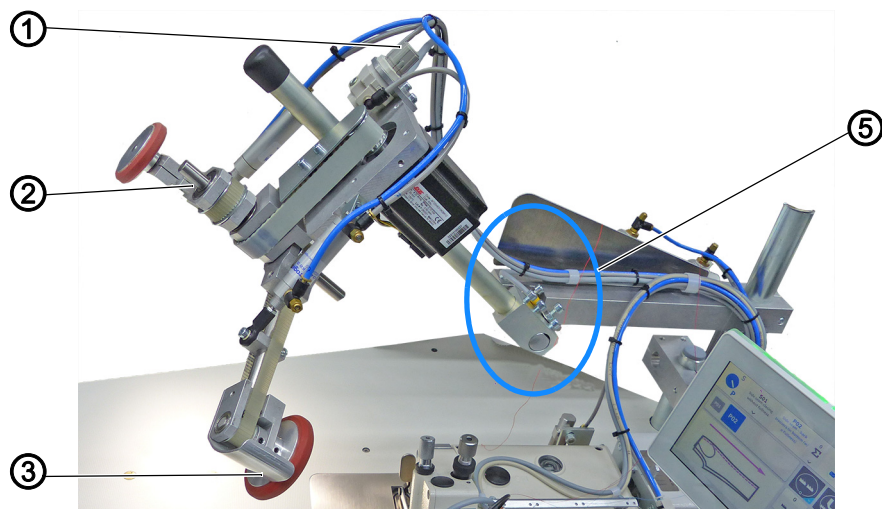

- (1) - Adjusting wheel
- (2) - Roll-out device
- (3) - Puller

- (5) - Rods including joint for additional lifting/lowering

Transport station with rods including joint for additional lifting/lowering (5) for sewing unit 1281-7.

4.15.1 Adjusting the puller

Fig. 45: Adjusting the puller

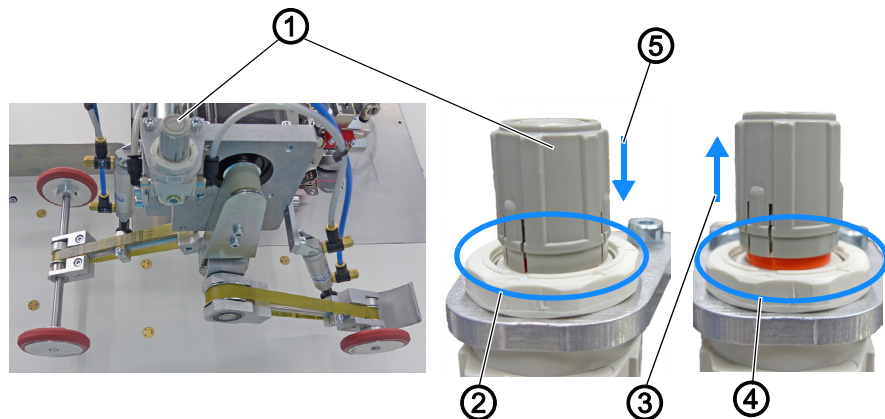

(1) - Adjusting wheel
(2) - locked

(3) - Arrow direction
(4) - released
(5) - Arrow direction



To adjust the pressure for the puller:

1. Pull the adjusting wheel (1) up in arrow direction (3).
 - ↪ The adjusting wheel (1) is released (4).
 - ↪ Indicated by the red marking.
2. Turn the adjusting wheel (1).
 - **More pressure:** Turn clockwise
 - **Less pressure:** Turn counterclockwise
3. Push the adjusting wheel (1) down in arrow direction (5).
 - ↪ The adjusting wheel (1) is locked

4.15.2 Operating the puller

Fig. 46: Operating the puller (1)

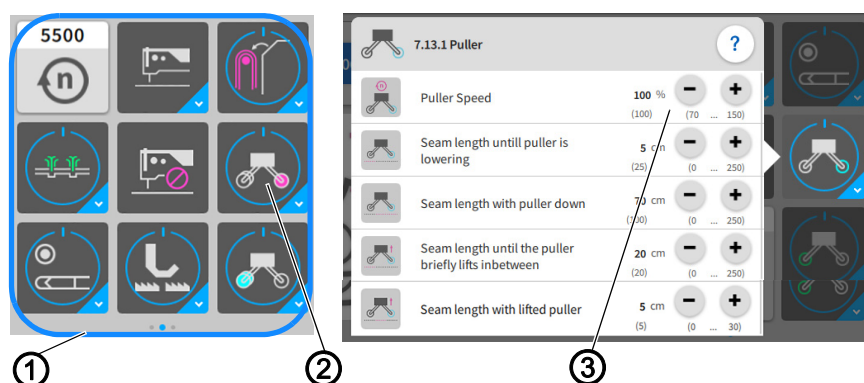

(1) - Quick Access Icons
(2) - Button Puller

(3) - Setting parameters

You can open and change the setting parameters (3) easily using the quick access icons (1) on the control panel found on the main page.



To operate the puller:

1. Press the *Puller* (2) button.
 - ↪ The puller is switched ON/OFF.
2. Perform a long press on the *Puller* (2) button.
 - ↪ The window for the setting parameters (3) opens.
3. You can change the setting parameters (3) to your requirements.
 - ↪ The new values are adopted automatically.

Puller speed

- **Puller faster:** increase the value if the sewing piece curls at the edge guide.
- **Puller slower:** reduce the value if the sewing piece is pushed away from the edge guide.



Information

You can use the program parameters on the control panel (📖 p. 123, 7.13 *Puller/Roll-out device*) to program the puller.

4.15.3 Operating the roll-out device

Fig. 47: Operating the roll-out device (1)

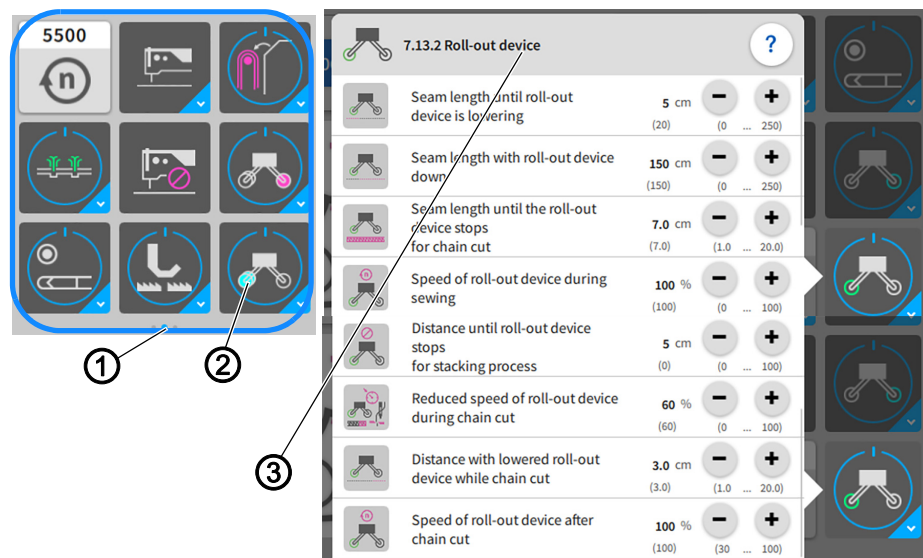

- (1) - Quick Access Icons
 (2) - Button Roll-out device

(3) - Setting parameters

You can open and change the setting parameters (3) easily using the quick access icons (1)/button Roll-out device (2) on the control panel found on the main page.



To operate the roll-out device:

1. Press the *Roll-out device* (2) button.
 - ↪ The roll-out device is switched ON/OFF.
2. Perform a long press on the button *Roll-out device* (2).
 - ↪ The window for the setting parameters (3) opens.
3. You can change the setting parameters (3) to your requirements.
 - ↪ The new values are adopted automatically.
 - ↪ The roll-out device transports the sewing piece to the stacker



Information

You can use the program parameters on the control panel ( p. 123, 7.13 *Puller/Roll-out device*) to program the roll-out device.

4.16 Pneumatic swing out device with stamp (option 1280)

WARNING



Risk of injury from moving parts!

Crushing possible.

While swiveling is in progress, DO NOT reach into the working area of the stamp.

Fig. 48: Pneumatic swing out device with stamp (1)

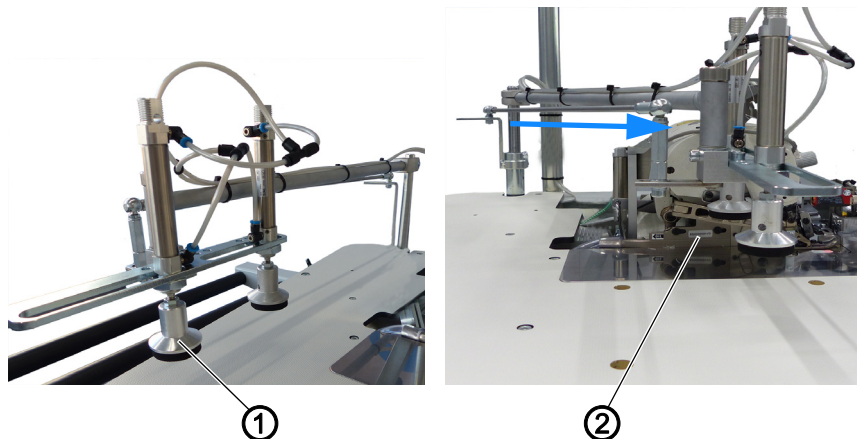

(1) - Position left

(2) - Position right

The pneumatic swing out device with stamp assists the sewing material during the thread chain cut and while it is being swung towards the stacker following the sewing process. The pneumatic swing out device with stamp works exceptionally well on short sewing material and when sewing starts at the trousers hem.

The pneumatic swing out device with stamp on the tabletop can swivel.

- The position on the left (1) indicates the initial position of the stamp.
- The blue arrow indicates the swivel direction of the stamp.
- The position on the right (2) indicates the completed swivel movement of the stamp.

When the sewing process has finished, the stamps lower to position (2) before the sewing material is first swiveled towards the stacker and then stacked.



Information

You can use the program parameters on the control panel (📖 p. 123, 7.8 *Swing out device*) to program the pneumatic stamp.

Fig. 49: Pneumatic swing out device with stamp (2)

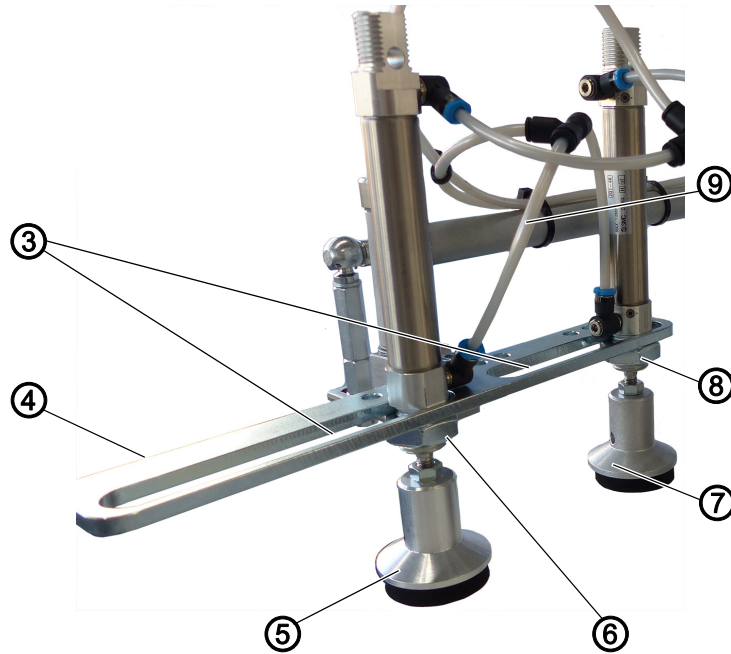

(3) - Slot
(4) - Holder
(5) - Stamp

(6) - Screw
(7) - Stamp
(8) - Screw
(9) - Pneumatic hose

Stamp position distance

The distance of stamps (5) and (7) can be set individually as needed and to match the size of the sewing material.



To adjust the stamp positions:

1. Loosen screw (6) and/or screw (8).
2. Slide stamp (5) and/or stamp (7) to the desired position in their respective slot (3).
3. Tighten screw (6) and/or screw (8).



Important

The pneumatic hose (9) must have enough play to keep it from being torn off during the swiveling process.

4.17 Mouse station with guide rail and retrieval device (1281)

WARNING



Risk of injury from sharp and moving parts!

Puncture or crushing possible.

Do not reach into the open mouse.

Fig. 50: Mouse station with guide rail and retrieval device

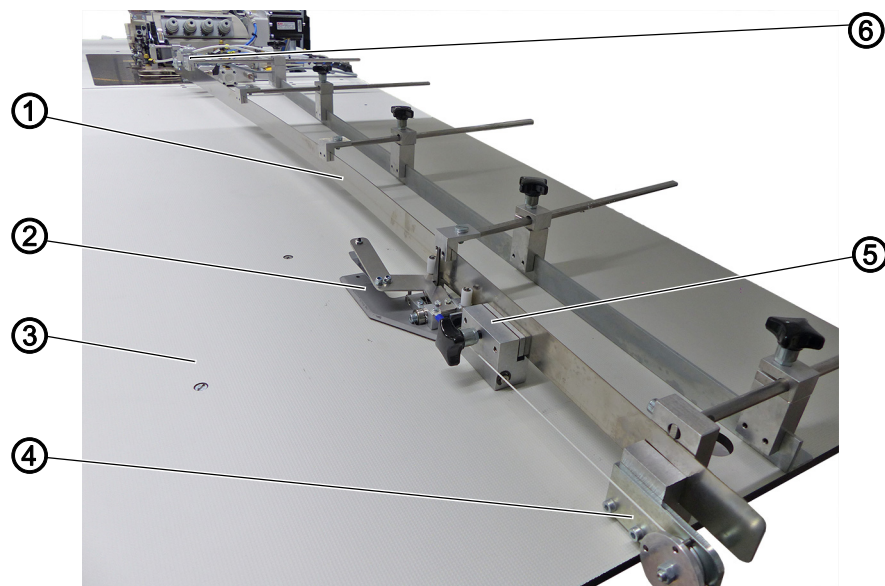

- | | |
|---------------------|------------------------|
| (1) - Guide rail | (4) - Retrieval device |
| (2) - Mouse station | (5) - End stop - rear |
| (3) - Worktable | (6) - End stop - front |

Worktable (3) with mouse station (2) and retrieval device (4) for overlapped working. The flexibly adjustable guide rail (1) can be adapted quickly to different seam contours. The mouse station (2) is used to fix the seam ends, e.g. of the trousers hem, in place in order to guide the sewing material during the sewing process. It moves along the guide rail (1) from the end stop - rear (5) to the end stop - front (6). The retrieval device (4) automatically pulls the mouse station (2) back to the start position at the end stop - rear (5).

4.17.1 Aligning the guide rail

Fig. 51: Aligning the guide rail

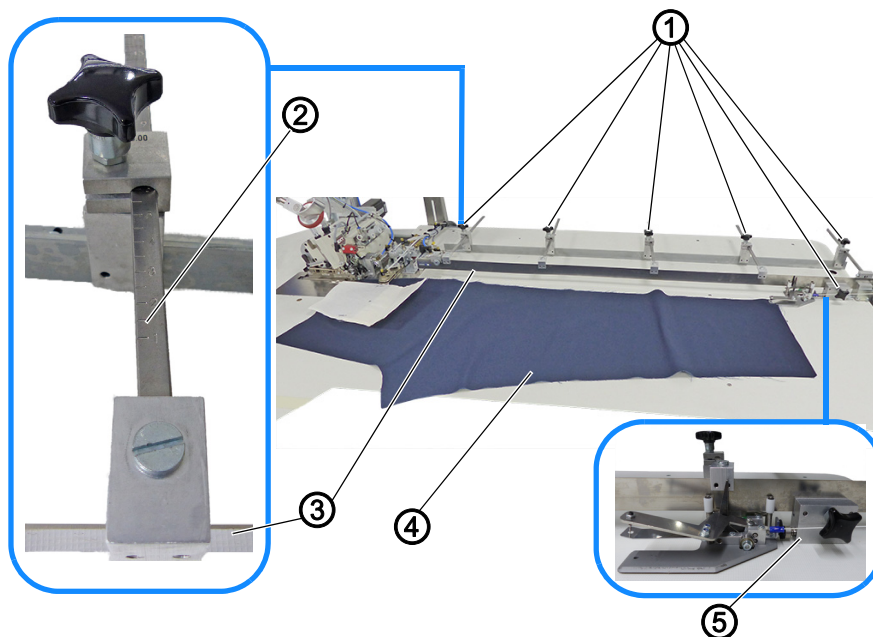

(1) - Tommy screw
(2) - Metric measuring scale

(3) - Guide rail
(4) - Sewing piece
(5) - End stop - rear



Proper setting

The guide rail (3) is flexible and mirror-inverted to the seam to be sewn.



To adjust the guide rail:

1. Lay the sewing piece (4) out smoothly on the worktable with the sewing direction.
 2. Loosen all tommy screws (1).
 3. Set the guide rail (3) such that it is mirror-inverted to the contour of the sewing piece (4) and tighten the corresponding tommy screw (1).
- ↳ The metric measuring scale (2) is a useful tool for this task.
4. Position the end stop-rear (5) at the end of the sewing piece (4) and tighten the tommy screw (1).

4.17.2 Operating the mouse station

Fig. 52: Operating the mouse station (1)

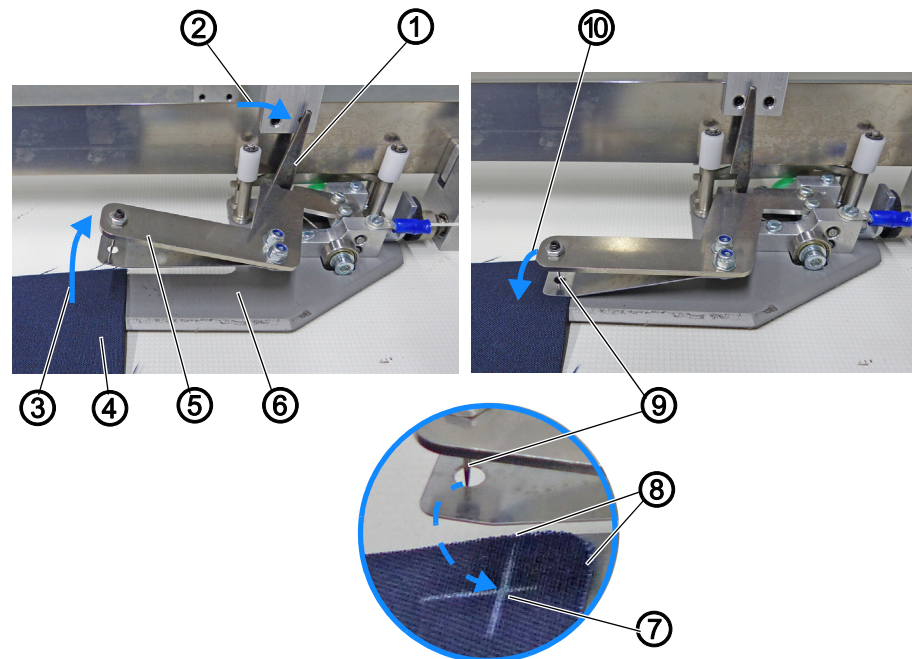

- (1) - Lever
- (2) - Arrow direction
- (3) - Arrow direction
- (4) - Sewing piece
- (5) - Mouse clamp

- (6) - Mouse plate
- (7) - Position
- (8) - Material cutting edges
- (9) - Needle
- (10) - Arrow direction



Proper setting

The start position for the mouse station is always located at the end stop-rear (18).



To operate the mouse station:

1. Lay the sewing piece (4) out smoothly on the worktable with the sewing direction.
2. Move the lever (1) manually in arrow direction (2) if it is closed.
 - ↪ The mouse clamp (5) opens towards the top in arrow direction (3).
 - ↪ The lever (1) is usually open as the end stop-front (11) opens it automatically (see step 5).
3. Insert the sewing piece (4) between the mouse plate (6) and the mouse clamp (5). Push the mouse clamp (3) down manually in arrow direction (10).
 - ↪ The sewing piece (4) is fixed in place with the needle (9) and clamped in position in the mouse station.



Important

To achieve a good sewing result, the position (7) of the sewing piece (4) should be fixed in place with the needle (9) at a distance of approx. 1 cm from the material cutting edges (8) in the mouse station.

Fig. 53: Operating the mouse station (2)

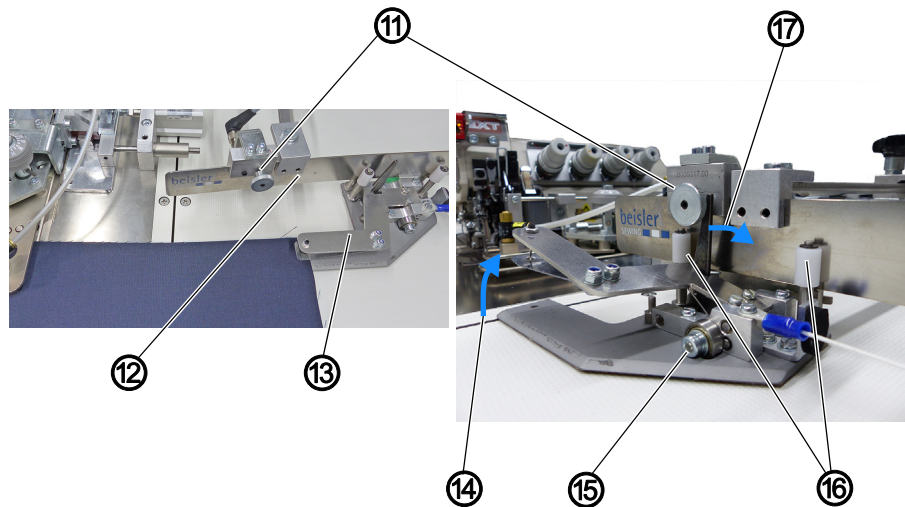

(11) - End stop - front
(12) - Guide rail
(13) - Mouse station

(14) - Arrow direction
(15) - Guide roller
(16) - Guide pins
(17) - Arrow direction



4. While the sewing process is in progress, the mouse station (13) is guided along the guide rail (12) by the guide roller (15) and the guiding pins (16).
5. Once it reaches the end stop-front (11), the opening of the mouse clamp (5) is triggered automatically.
 - ↪ The lever (1) is moved in arrow direction (17) by the end stop-front (11).
 - ↪ The mouse clamp (4) opens towards the top in arrow direction (14).
 - ↪ The sewing piece (4) detaches from the needle (9) and thus from the mouse station (13).

Fig. 54: Operating the mouse station (3)

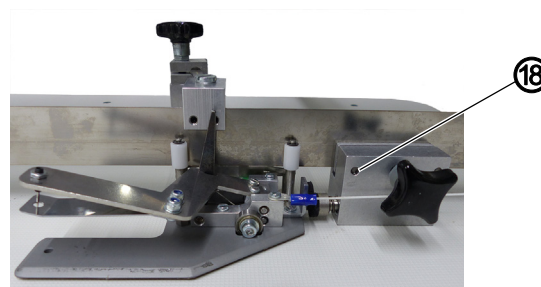

(18) - End stop - rear



6. The mouse station (13) is pulled back by the retrieval device (📖 p. 61) until it abuts on the end stop-rear (18).

4.17.3 Retrieval device of the mouse station

Fig. 55: Retrieval device of the mouse station

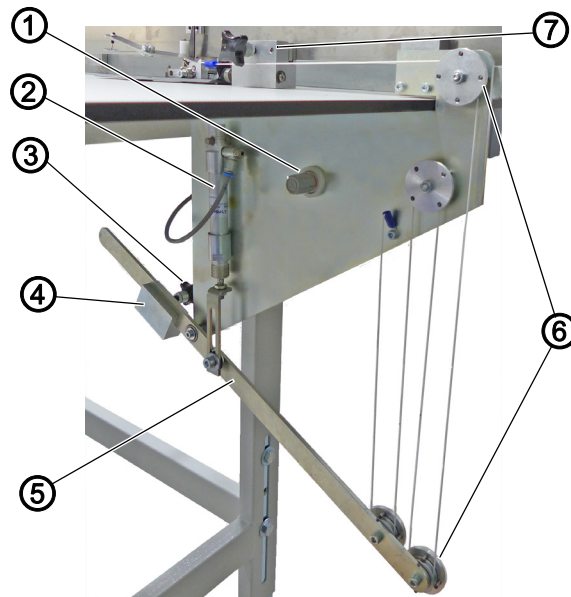

- | | |
|--------------------------|---------------------------|
| (1) - Adjusting wheel | (5) - Mouse mechanics |
| (2) - Pneumatic cylinder | (6) - Retrieval mechanism |
| (3) - Tommy screw | (7) - End stop - rear |
| (4) - Weight | |

The pneumatic cylinder (2) pushes the mouse mechanics (5) down and pulls the mouse back to the end stop-rear (7) by means of the retrieval mechanism (6). The pulling force and the retrieval speed of the mouse can be adjusted manually.



To adjust the pulling force of the mouse station:

1. Loosen the tommy screw (3)
2. Shift the position of the weight (4) on the mouse mechanics (5).
 - **More pulling force:** Shift the weight (4) outward.
 - **Less pulling force:** Shift the weight (4) inward.
3. Tighten the tommy screw (3).



To adjust the retrieval speed of the mouse station:

1. Pull the adjusting wheel (1) to the front.
 - ↪ The adjusting wheel (1) is released (3).
2. Turn the adjusting wheel (1).
 - **Speed higher:** Turn clockwise
 - **Speed lower:** Turn counterclockwise
3. Engage the adjusting wheel (1).
 - ↪ The adjusting wheel (1) is locked

4.18 Sewing

WARNING



Risk of injury from sharp and moving parts!



Puncture or crushing possible.

Only qualified specialists may operate the machine.



Information 1280/1281





Feed of the sewing material

To ease the feed of the sewing material in the area of the sewing head, you should activate the table air nozzles ( p. 123, 7.4 *Table blowing*) and the roll-out device ( p. 123, 7.13 *Roll-out device*) in the seam beginning area using the program parameters on the control panel.

Sewing start mode

There are 3 different sewing start modes which can be set individually for each program.

The following settings are recommended:

1. Start mode 1: Inseam
 -  Fully automatic sewing start via light barrier recognition.
2. Start mode 2: Inseam/side seam
 -  Manual sewing start/Manual sewing via pedal, then activate the automatic sewing start after xxxx cm.
3. Start mode 3: Side seam
 -  Manual sewing start/Manual sewing via pedal, then press pedal to activate automatic sewing start.
4. Sewing length until automatic sewing start: Only relevant for start modes 2 and 3.
 -  Setting the seam length in cm until automatic change to automatic sewing start while the pedal must remain pressed.



Important 1280/1281

In accordance with the sewing start mode stored in the program, the automatic sewing process will begin as soon as the manual sewing process via pedal ( p. 70) is complete.

4.18.1 Operating the workstation: 1280-7



To insert the sewing pieces and start the sewing process:

1. Deposit the sewing material on the delivery table.
 - Optionally to the left of the right of the worktable (📖 p. 190)
2. Use the control panel (📖 p. 72) to call up the desired seam program (📖 p. 115).
3. Place and align the sewing pieces (2) in pairs and on top of each other on the worktable.

Fig. 56: Operating the workstation 1280-7 (1)

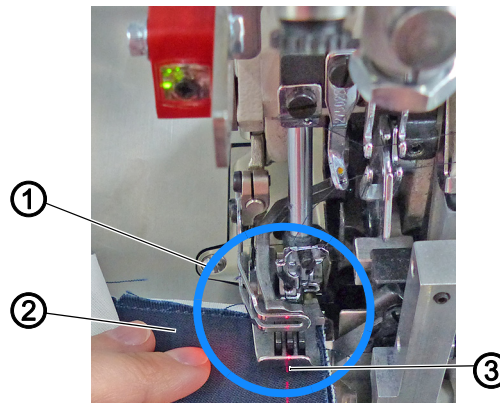

- (1) - Advance the sewing pieces under the (2) - Sewing pieces
sewing foot until you reach the needle (3) - Marking lamp



4. Advance the sewing pieces under the sewing foot until you reach the needle (1).
- ↳ To ensure that the feed dogs will safely catch the sewing material.
5. The marking lamp (3) (optional) (📖 p. 37) indicates the seam course.

Fig. 57: Operating the workstation 1280-7 (2)

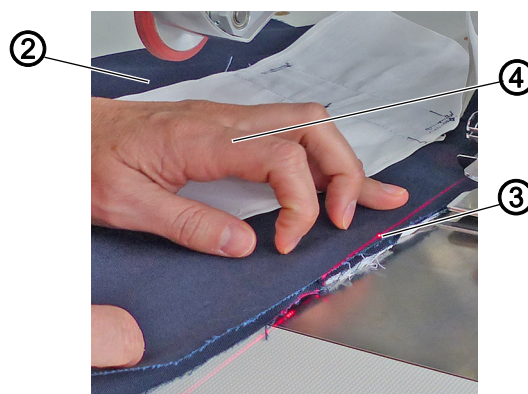

- (2) - Sewing pieces (4) - left hand
(3) - Marking lamp



6. Hold the sewing pieces (2) in place with the left hand (4) and align them at the same time.
- ↳ The marking lamp (3) (optional) makes it easier to align the sewing pieces (2) in the area of the pocket opening/hip curve.

Fig. 58: Operating the workstation 1280-7 (3)

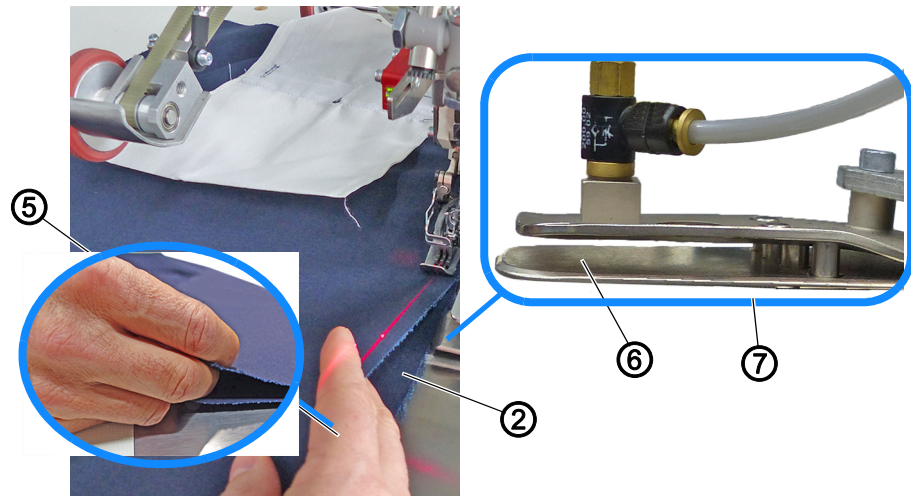

- | | |
|---------------------|---------------------|
| (2) - Sewing pieces | (6) - Middle tongue |
| (5) - right hand | (7) - Contour guide |



7. Grab the sewing pieces (2) with the fingers of your right hand (5) during the manual sewing process.
 - Thumb and index finger: on the top sewing piece (2).
 - Middle finger: between the sewing pieces (2).
 - Ring finger: under the bottom sewing piece (2).
- ↪ The top sewing piece (2) is slightly lifted by the middle finger of your right hand (5), allowing the middle tongue (6) of the contour guide (7) to slide between the sewing pieces (2).
8. Press the pedal backwards and sew the first part of the seam manually.

Fig. 59: Operating the workstation 1280-7 (4)



- | | |
|---------------------|---------------------|
| (2) - Sewing pieces | (7) - Contour guide |
| (6) - Middle tongue | |



9. Press the knee button (📖 p. 28)/press the pedal forwards.
 - ↪ The contour guide (7) (📖 p. 27) extends crosswise to the seam.
 - ↪ At the same time, the middle tongue (6) of the contour guide (7) slides between the sewing pieces (2).
10. Press the pedal backwards.

11. Keep the pedal depressed until the machine switches to automatic sewing start. You can program the length of the seam section (📖 p. 70).

Fig. 60: Operating the workstation 1280-7 (5)

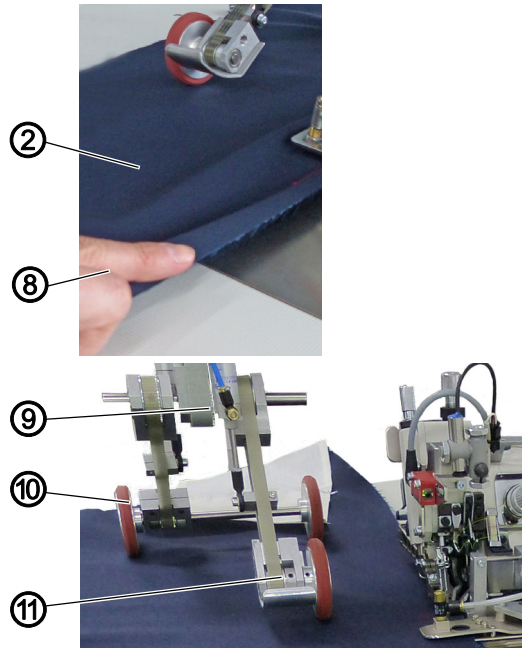

(2) - Sewing pieces
(8) - right hand

(9) - Transport station
(10) - Roll-out device
(11) - Puller



12. If necessary, keep guiding the sewing pieces (2) with your right hand (8).
13. Release the sewing pieces (2).
14. The transport station (9) (📖 p. 50) lowers during the sewing process (depending on the equipment, with holding stamp/puller with roll-out device).
15. The puller (11) in the transport station (9) lowers.
 - ↙ To keep the sewing pieces (2) from slipping.
 - ↙ To support the feed of the sewing pieces (2).
16. The roll-out device (10)/holding stamp in the transport station (9) lowers.
 - ↙ To ensure reliable chain cutting.
 - ↙ To transport the sewing pieces (2) away from the sewing area and to the stacker.
17. The finished sewing pieces (2) are stacked (📖 p. 39).
18. Manually remove the pieces from the stacker.

4.18.2 Operating the workstation: 1281-7



To insert the sewing pieces and start the sewing process:

1. Deposit the sewing material on the delivery table.
 - Optionally, one delivery table/two delivery tables
2. Use the control panel (📖 p. 72) to call up the desired seam program (📖 p. 115).
3. Place and align the sewing pieces (3) in pairs and on top of each other on the worktable.



Important

You should first mirror-invert the guide rail to the seam (📖 p. 58), as the seam will otherwise run out of the sewing material or the seams will have inconsistent widths.

Fig. 61: Operating the workstation 1281-7 (1)

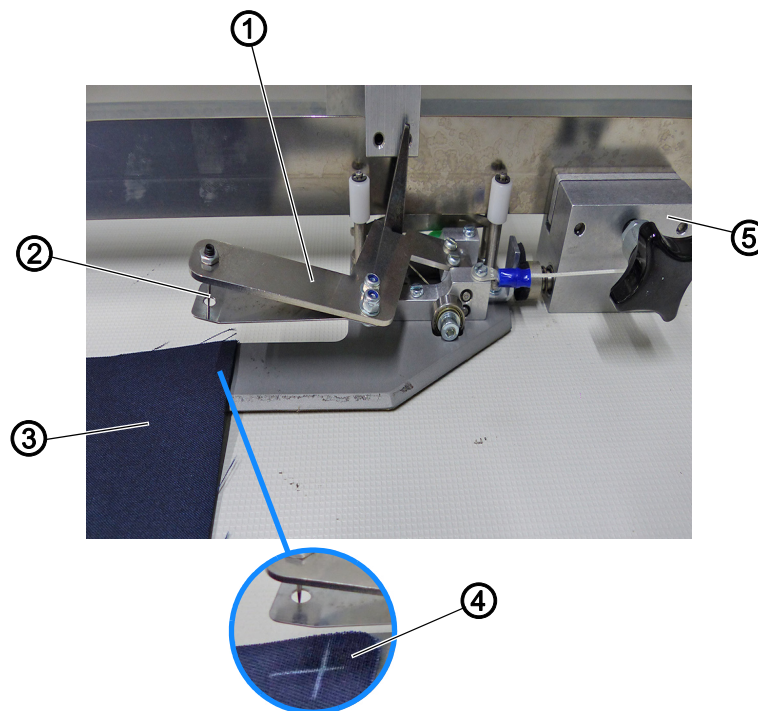

- (1) - Mouse station
(2) - Needle
(3) - Sewing pieces

- (4) - Position
(5) - End stop - rear



4. Insert the sewing pieces (3) into the mouse station (1) at the end stop-rear (5) and fix them in place with the needle (2) (📖 p. 59).



Information

You achieve the best sewing results when choosing a position (4) for the sewing pieces (3) in the mouse station (1) that is approx. 1 cm away from the material cutting edges.

Fig. 62: Operating the workstation 1281-7 (2)

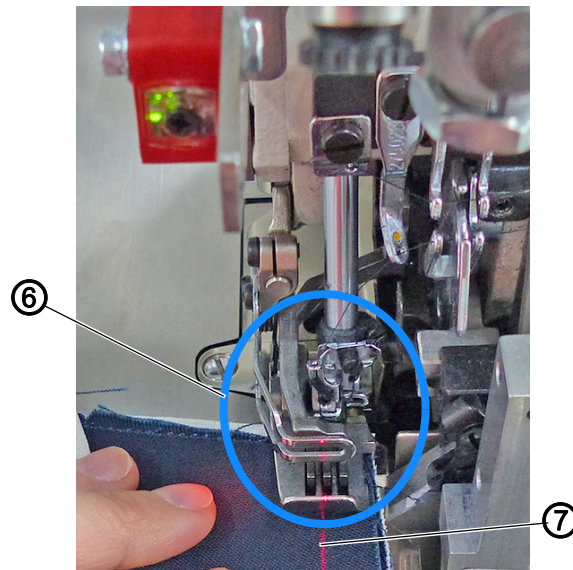

- (6) - Advance the sewing pieces under the sewing foot until you reach the needle
 (7) - Marking lamp



5. Advance the sewing pieces under the sewing foot until you reach the needle (6).

↙ To ensure that the feed dogs will safely catch the sewing material.

6. The marking lamp (7) (optional) (📖 p. 37) indicates the seam course.

Fig. 63: Operating the workstation 1281-7 (3)

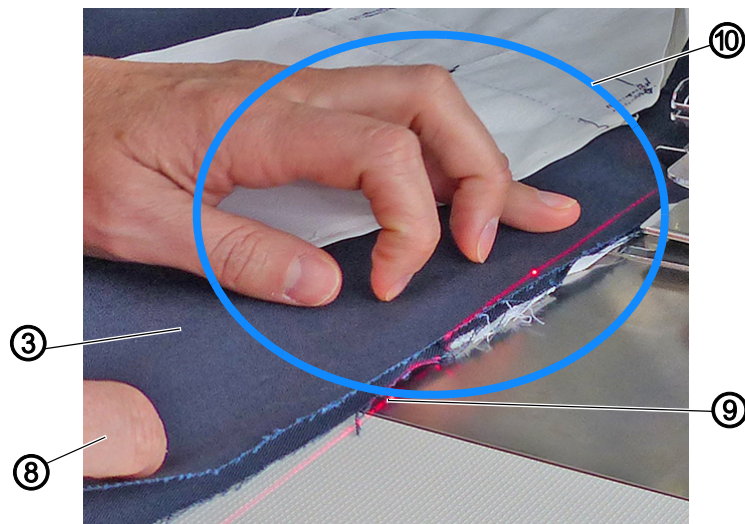

- (3) - Sewing pieces
 (8) - Right hand

- (9) - Marking lamp
 (10) - Area of the pocket/hip curve



7. Press the pedal backwards.

↙ To manually sew the first part of the seam in the area of the pocket/hip curve (10).

↙ The marking lamp (9) (optional) makes it easier to align the sewing pieces (3) in the area of the pocket/hip curve (10)

8. Separate the sewing pieces (3) below the area of the pocket/hip curve (10).
 - ↪ The top sewing piece (3) is slightly lifted by the right hand (8).

Fig. 64: Operating the workstation 1281-7 (4)

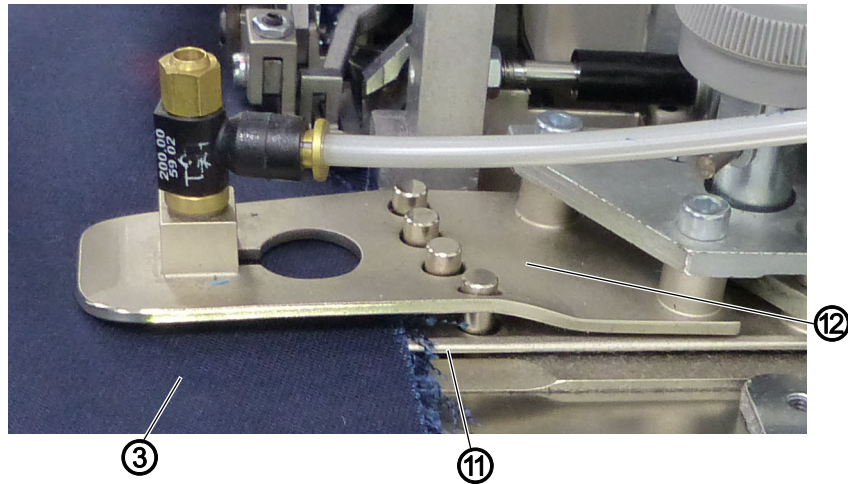

(3) - Sewing pieces
(11) - Middle tongue

(12) - Contour guide

9. Press the pedal forwards.
 - ↪ The contour guide (12) ([p. 27](#)) extends crosswise to the seam.
 - ↪ At the same time, the middle tongue (11) of the contour guide (12) slides between the sewing pieces (3).

Fig. 65: Operating the workstation 1281-7 (5)



(1) - Mouse station
(3) - Sewing pieces

(13) - Guide rail



10. Press the pedal backwards.
11. Keep the pedal depressed until the machine switches to automatic sewing start. You can program the length of the seam section ([p. 70](#)).

12. Release the sewing pieces (3).

- ↗ The sewing material is fed to the sewing head by the mouse station (1) and the guide rail (13).

Fig. 66: Operating the workstation 1281-7 (7)

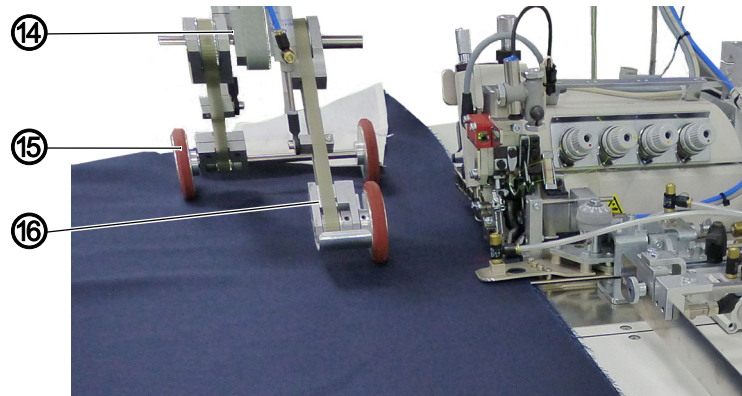

(14) - Transport station
(15) - Roll-out device

(16) - Puller



13. The transport station (14) lowers (📖 p. 50).

14. The puller (16) in the transport station (14) lowers.

- ↗ To keep the sewing material from slipping.

- ↗ To support the feed of the sewing material.

15. The roll-out device (15) in the transport station (14) lowers.

- ↗ To ensure reliable chain cutting.

- ↗ To transport the sewing material away from the sewing area and to the stacker.

Fig. 67: Operating the workstation 1281-7 (8)

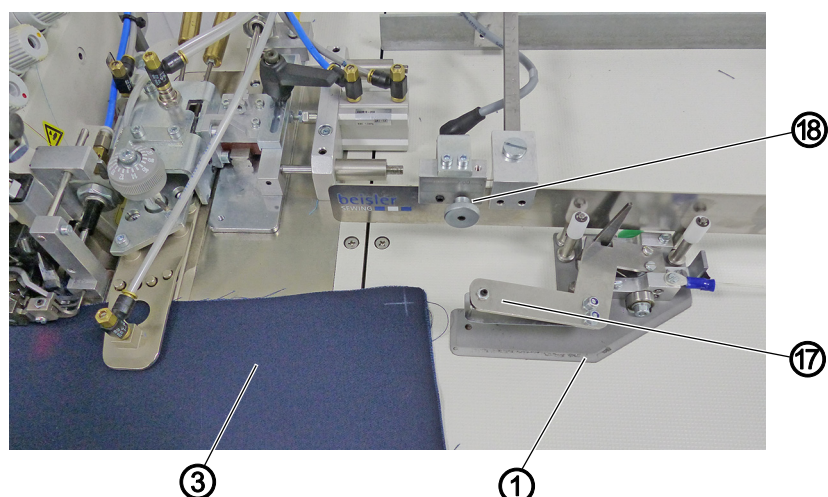

(1) - Mouse station
(3) - Sewing pieces

(17) - Mouse clamp
(18) - End stop - front



16. The mouse station (1) reaches the end stop-front (18).

- ↗ The opening of the mouse clamp (17) is triggered automatically.

- ↗ The sewing pieces (3) detach from the mouse station (1) (📖 p. 59).

17. The mouse station (1) automatically returns to the end stop-rear (5) (📖 p. 61).
18. The finished sewing pieces are stacked (📖 p. 39).
19. Manually remove the pieces from the stacker.

4.19 Foot pedal

Fig. 68: Foot pedal



(19) - Foot pedal

The foot pedal is a standard component of the machine.



Information

There are various options for the manual sewing by foot pedal (1), which is converted into an automatic sewing start.

You can use the program parameters on the control panel (📖 p. 123, 7.2.6 *Start mode*) to program start mode 1, 2 or 3.

5 Programming Commander Pro

5.1 Commander Pro control panel

Fig. 69: Commander Pro control panel



All settings in the software for the machine are performed using the Commander Pro control panel.

5.1.1 Starting up the screen



To start up the screen:

1. Turn on the main switch of the machine ( p. 15).
- ↳ The machine starts up.
The control initializes.
The start screen is displayed.

5.2 LED light strip

Fig. 70: Control panel LED light strip

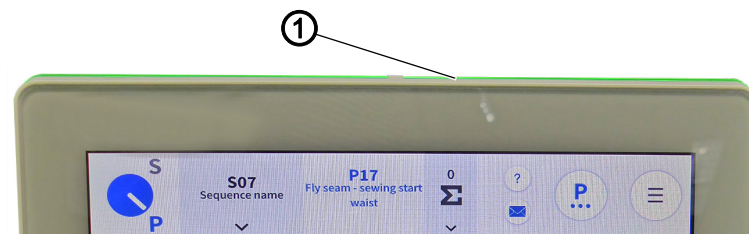

(1) - LED light strip

The color of the LED light strip (1) indicates to the user to which mode the machine is currently set. There are 4 colors, all assigned to a specific area.

The meaning of the 4 colors is specified below:

- green = normal status
- blue = information notice
- yellow = warning
- red = error message

5.3 Navigating the Commander Pro control panel

You navigate the control panel by tapping the screen with your fingers. There is no need for an input device.

You can open menus by pressing the corresponding button with your finger. You switch between the different pages of the start screen by swiping with one finger to the right or the left.

In the submenus the user can switch between entries by scrolling. Manual entries to change names or numerical values can be made with a long press or a quick double click. The switch of a program sequence or of the quick access icons is made using the interaction: Drag and drop.

When the control panel has finished starting up, you can immediately access the user interface. The tiles on the control panel can be selected as soon as they have become visible.

Fig. 71: Navigating the Commander Pro control panel (1)

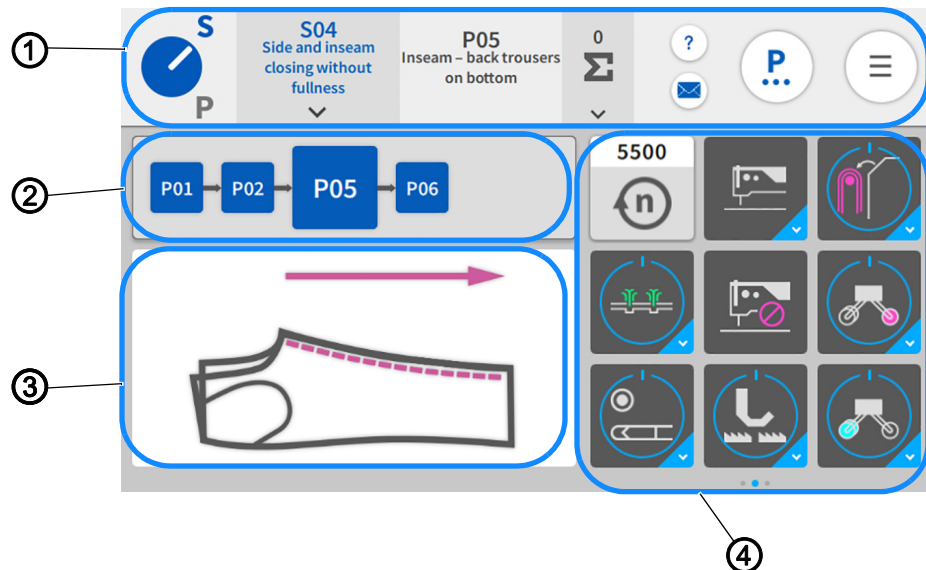

(1) - Status bar
(2) - Sequence bar

(3) - Sewing graphics
(4) - Quick access panel



This is what the start screen looks like.

The start screen also functions as the main screen and the main level on which the machine is ready to sew. The screen is divided into 4 areas.

1. Status bar (1) (📖 p. 74)
2. Sequence bar (2)
3. Sewing graphics (3)
4. You can customize the quick access panel (4) per sequence and swipe across its 3 pages from the right to the left.

Fig. 72: Navigating the Commander Pro control panel (2)

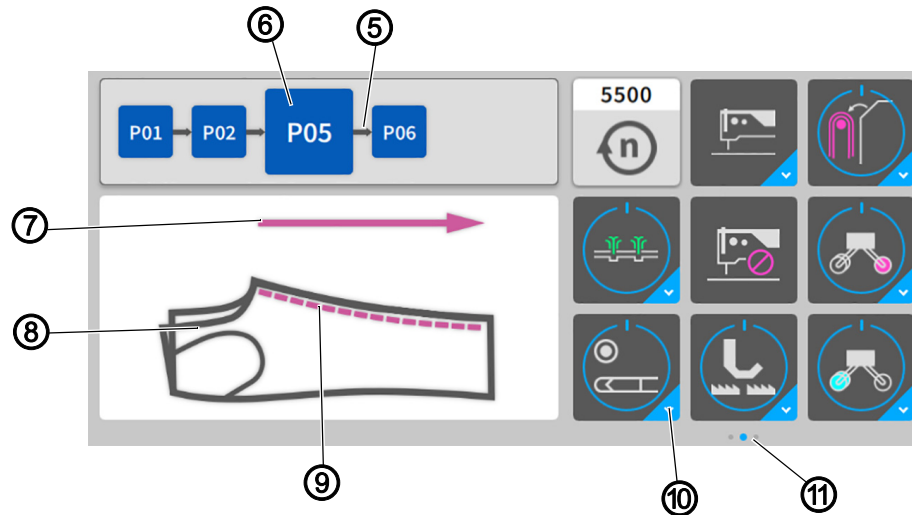









- | | |
|------------------------|----------------|
| (5) - Program sequence | (9) - Red seam |
| (6) - Active program | (10) - Tiles |
| (7) - Red arrow | (11) - Pages |
| (8) - Sewing material | |

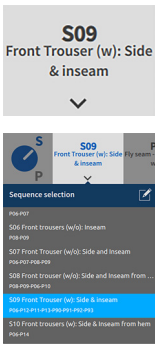







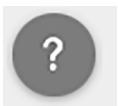

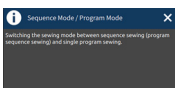







Displayed in the sequence bar (2) is the program sequence (5) of the current sequence. The active program (6) is always highlighted in bold and displayed as a red seam (9) next to the sewing graphics (3) immediately on the sewing material (8). The red seam (9) in the sewing graphics (3) changes along with each program change in the program sequence (5). The red arrow (7) indicates the sewing direction.









The quick access panel (4) holds the tiles (10) that are used to change the program parameters. They can be customized and grouped across 3 pages (11) and 27 placeholders (📖 p. 157). The blue dot indicates the active page (11).

5.3.1 Symbols and tiles

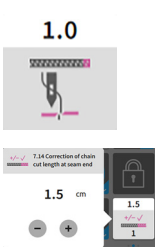
Explanation of recurring symbols and tiles:

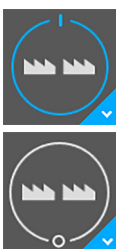
Icon	Meaning
	<p>S/P toggle</p> <p>S = sequence mode</p> <p>P = program mode</p> <p>The blue letter indicates the active mode.</p> <p>Press the symbol to toggle between the two modes.</p> <p>The white pointer indicates the active mode.</p>
	<p>Sequence name</p> <p>Display of the number and name of the active sequence.</p> <p>A press of the  symbol takes the user to the sequence selection. The sequence selection allows the user to change between 40 different sequences and enter the sequence programming level with a press of the  symbol (📖 p. 150).</p>
	<p>Program name</p> <p>Display of the number and name of the current program.</p>
	<p>Piece counter</p> <p>Display in accordance with the counting setting.</p> <p>A press of the  symbol takes the user to the option for adjusting additional settings (📖 p. 114)</p>
	<p>Context-sensitive help</p> <p>The information  about the desired symbol is displayed.</p> <p>Short press: The help function is highlighted in gray = 1x Help</p> <p>Long press: The help function is highlighted in light blue = use Help several times in a row.</p> <p>To release: Press x1.</p>
	<p>Press on the area for which you need help - this brings up a window containing a Help text.</p> <p>Press X; the window closes.</p> <p>The help function highlighted in gray becomes inactive automatically.</p>

Icon	Meaning
	<p>Press on the area for which you need help - this brings up a window containing a Help text. Press X; the window closes. The help function highlighted in light blue remains active and allows the user to request help in other areas. Not until the area is pressed again will the light blue help function become inactive.</p>
	<p>Window and Help text Help text is marked for the user by the symbol . Help texts explaining the function are displayed for the individual menu items. The Help window is closed with a press of .</p>
 	<p>Messages The protocol data of the machine is displayed. All messages and error messages along with their respective error code that have occurred until this point will be displayed.</p>
	<p>Navigation menu A press of this button always takes the user to the navigation menu with the following options: Sequence Programming, Program Parameters, Settings, Tutorials, Logout/Change current user ( p. 82).</p>
	<p>Sequence Programming Access via the main screen or the navigation menu ( p. 150).</p>
	<p>Program Parameters The parameter view with different programs and templates is displayed. Access via the main screen, the navigation menu or the program parameters ( p. 115).</p>
	<p>Settings Access via the navigation menu ( p. 82).</p>
	<p>Tutorials Help videos and PDF files provided by the manufacturer on operating and cleaning the machine. Access via the navigation menu ( p. 109).</p>
	<p>Home A press of this button always takes the user back to the start screen ( p. 72).</p>
	<p>Back A press of this button always takes the user back to the previous screen page</p>

Icon	Meaning
	Quick access panel To change the program parameters for the selected program on the main screen (📖 p. 157).
	Machine function active = sewing head on dark tile The screen is active and can be used immediately using the touch display. All machine functions are available. The machine is ready for sewing
	Machine function inactive = sewing head on bright tile The screen is locked. All machine functions are locked. The machine is not ready for sewing.
	Bright tiles The numerical value integrated in the white line indicates the value for this parameter. A press of the button brings up a window allowing the user to change the range of values using the + and - buttons. The corresponding measuring unit is displayed to make this task easier. The new numerical value is adopted into the white line.
	Dark tiles The dark tiles can be set to active or inactive by pressing on them. A tap of the tile will trigger the desired process once.
	Dark tiles with a lower blue corner A press of such a tile automatically takes the user to the parameter section where values can be input and changed.
	Multifunction button with lower blue corner Dark tiles with round blue line = ON Dark tiles with round gray line = OFF The tile can be set to ON/OFF with a short press. A long press automatically takes the user to the parameter section where values can be input and changed.
	Threading mode All relevant machine functions are set to safety stop to allow for threading. At the same time, a threading diagram is displayed to provide assistance during threading (📖 p. 79).
grayed-out e.g. 	The function is inactive
blue e.g. 	The function is active

5.4 Locking and activating the machine functions

Fig. 73: Locking the machine functions

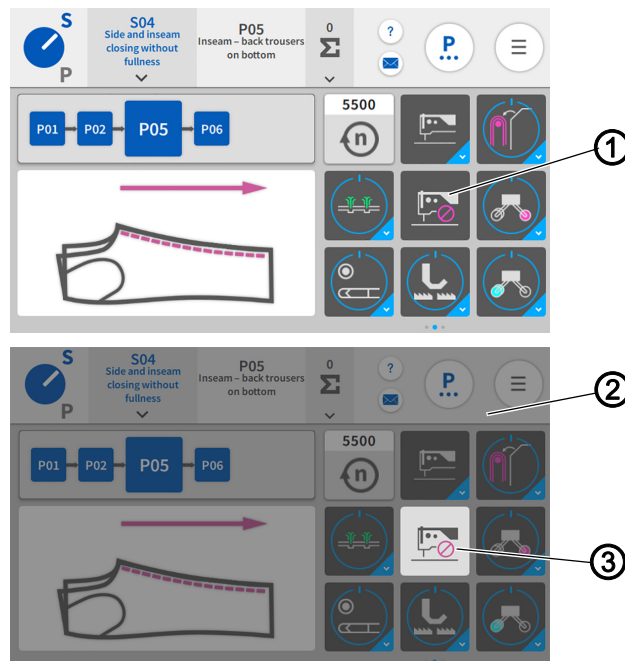

(1) - Sewing head

(3) - Sewing head

(2) - User interface



To lock the machine functions:

1. Tap the sewing head (1) highlighted in black.
- ↪ The sewing head (3) is highlighted in white.
- ↪ The entire user interface (2) is grayed-out.
- ↪ The screen is locked.
- ↪ All machine functions are locked.
- ↪ The machine is not ready for sewing.

To activate the machine functions:

1. Perform a long press on the sewing head (3) highlighted in white.
- ↪ The sewing head (3) is highlighted in black.
- ↪ The screen lock is canceled.
- ↪ The screen is active and can be used immediately using the touch display.
- ↪ All machine functions are available.
- ↪ The machine is ready for sewing.

5.5 Calling up threading mode

Fig. 74: Calling up threading mode

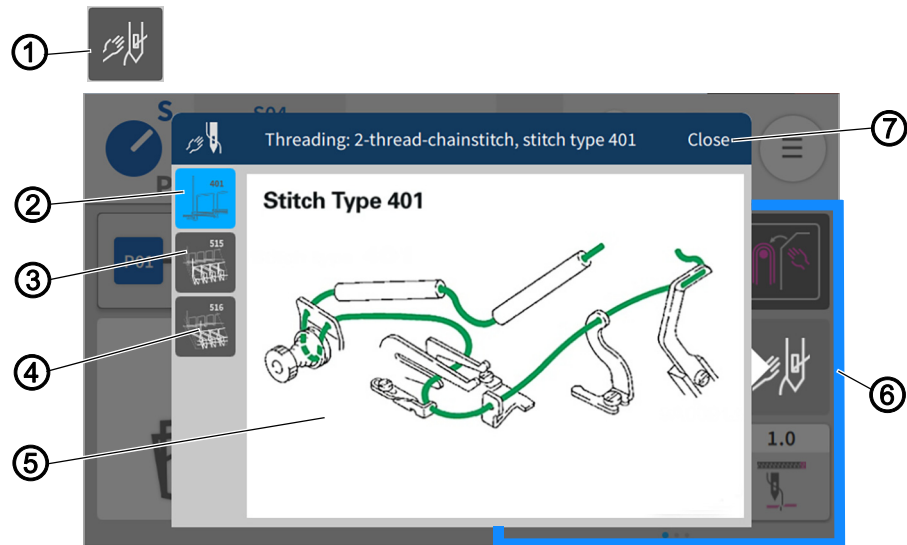

- | | |
|--|--------------------------|
| (1) - Tile Threading mode | (4) - Stitch type 516 |
| (2) - Stitch type 401 switched to active | (5) - Threading diagram |
| (3) - Stitch type 515 | (6) - Quick access panel |
| | (7) - Close |

The tile Threading mode (1) can be activated via the quick access icons (6). The threading diagram (5) is provided as an image to assist the user in threading the machine properly.

The threading diagram is selected via the stitch type: 401 (2), 515 (3) and 516 (4) at the top left.



To call up the threading diagram (5):

1. Press the tile Threading mode (1) on the quick access panel (6).
 - ↳ The user interface with the threading diagram (5) opens.
2. Press the desired stitch type: 401 (2), 515 (3) or 516 (4) at the top left.
 - ↳ The stitch type 401 (2) set to active is displayed in the window.
 - ↳ You can toggle back and forth between the stitch types: 401 (2), 515 (3) or 516 (4).
3. Press *Close* (7).
 - ↳ The view returns to the main screen.

5.5.1 Threading diagram

Depending on the sewing equipment, the machine can be threaded as a 2-, 4- or 5-thread variant.

2-thread variant: Stitch type 401, 2-thread chain stitch seam

Fig. 75: Stitch type 401

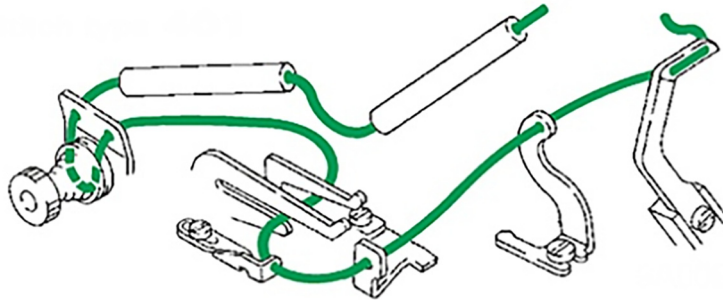

4-thread variant: Stitch type 515, 4-thread safety seam

Fig. 76: Stitch type 515

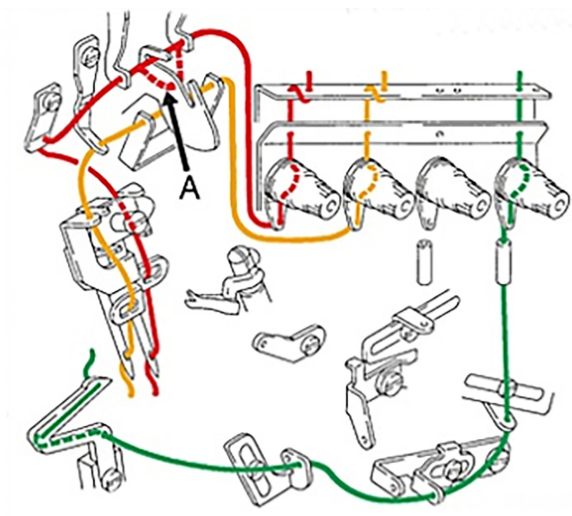

5-thread variant: Stitch type 516, 5-thread safety seam

Fig. 77: Stitch type 516

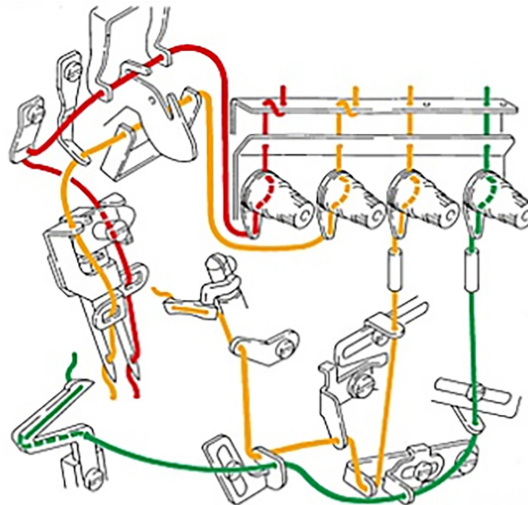

5.6 Entering numerical values



Information

If a numerical value is entered that is not within the specified value range, the software will automatically adopt the limit value which is closest to your entry from the value range.

You can input numerical values (1) using the buttons **-** or **+** or by typing on the integrated on-screen keyboard.

Fig. 78: Entering numerical values

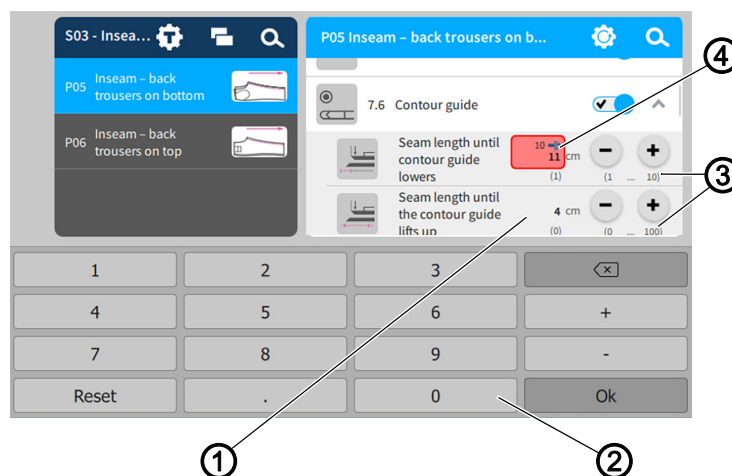

(1) - Numerical value
(2) - On-screen keyboard

(3) - Specified value range
(4) - Invalid numerical value



To access the integrated on-screen keyboard:

1. Tap once on the numerical value (1) you wish to change.
 - ↳ The integrated on-screen keyboard (2) is displayed, and the numerical value you wish to change is marked by a blue frame.
2. Use the on-screen keyboard (2) to enter the numerical value.
3. Press *OK*.
 - ↳ The value is stored, and the display returns to the previous user interface.



Important



Invalid numerical values (4) are highlighted in red and are not within the specified value range (3). The software responds to invalid numerical values (4) by automatically inputting the value range limit. Each specified value range (3) is given in brackets below the buttons **-** or **+**.

5.7 Changing program or sequence names

The names of the individual programs or sequences can be changed manually.



To change the names for programs and sequences:

1. Select the corresponding program
 -  Program Parameters
 -  Sequence Programming
2. Select the program/sequence you wish to change.
 - ↳ The program/sequence is set to active.
3. Press the active program/sequence twice in rapid succession.
 - ↳ The integrated on-screen keyboard is displayed and the text to be changed is marked by a purple frame.
4. Modify the text manually.
5. Press *Close*.
 - ↳ The text is saved and the display returns to the user interface *Program Parameters/Sequence Programming*.

5.8 Navigation menu

You can open the navigation menu with a press of the symbol .

Fig. 79: Navigation menu



5.9 Settings

Fig. 80: Settings

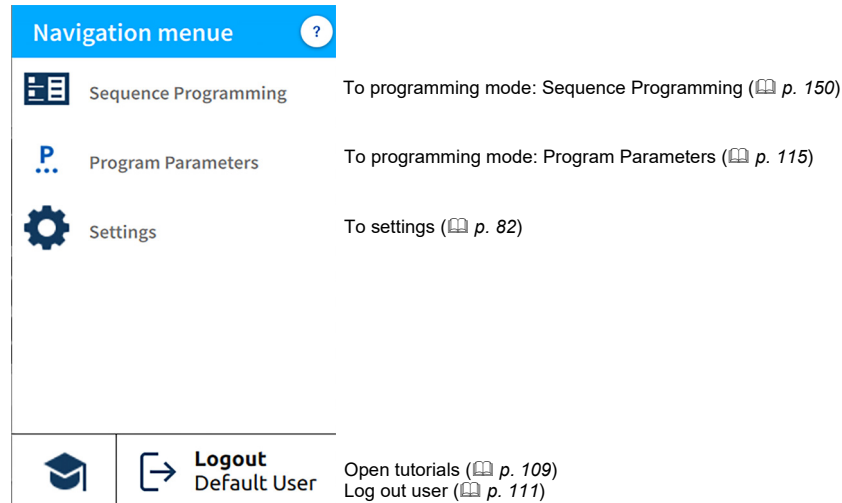
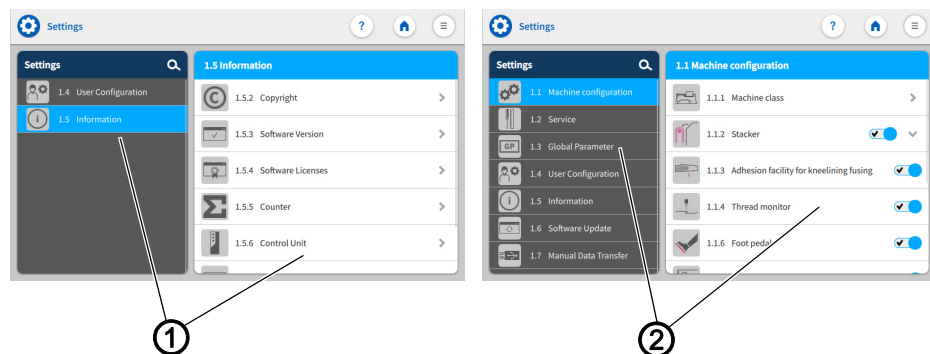

(1) - User interface *Default User* (2) - User interface *Default Technician*

The factory setting is such that the Default user will automatically be logged in when the machine starts and the control panel boots up. Displayed in the settings is the user interface *Default User* (1).

The factory setting for the Default Technician requires that the technician enter their username and password (*technician, 25483*) (p. 111). The Default Technician has more far-reaching authorizations than the Default User. Displayed in the settings is the user interface *Default Technician* (2).

After a restart of the machine, the user interface is changed back to the *Default User* (1).

The settings *User Configuration* and *Information* are identical for the Default User and the Default Technician. All options are detailed below.



5.9.1 User Configuration

The 1.4 *User Configuration* allows the currently logged-in user to customize the software user interface to their specific needs.



To access the User Configuration:

1. Press the symbol  to bring up the navigation pane
 ↳ The navigation menu opens.

Fig. 81: User Configuration (1)



(1) - Settings

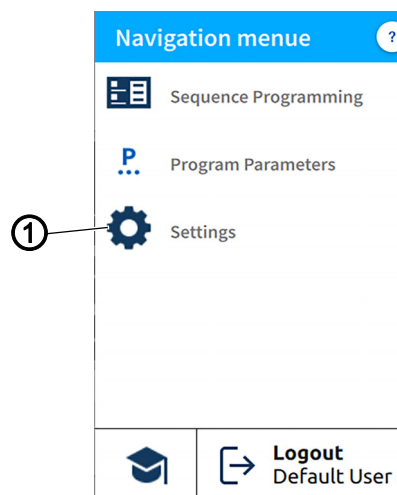

2. Press *Settings* (1).
 ↳ This opens the Settings user interface.

Fig. 82: User Configuration (2)

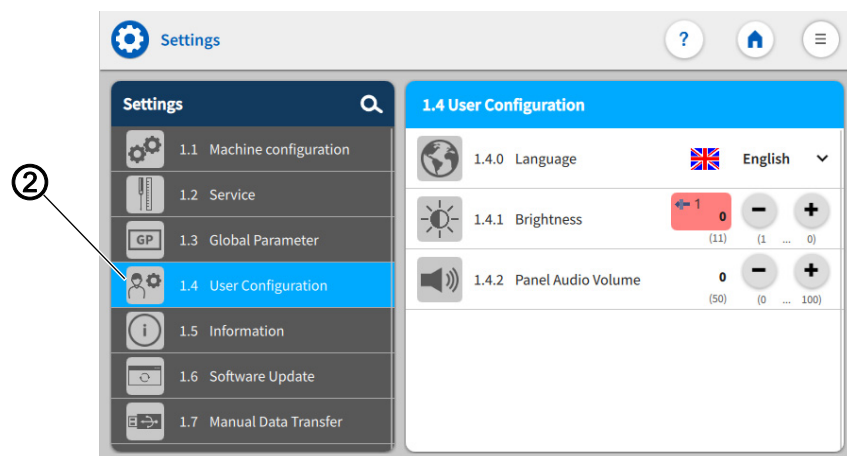

(2) - User Configuration



3. Press the option *User Configuration* (2) on the left.
 ↳ You are in the User Configuration.



5.9.2 Setting the language

Here, you can set the language of the software.

Fig. 83: Setting the language (1)

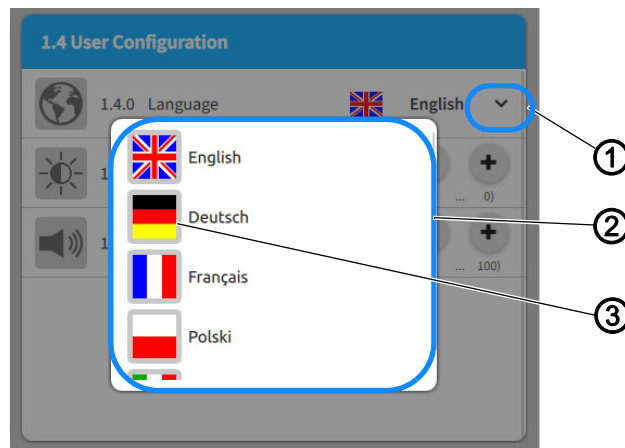

(1) - Submenu

(2) - List

(3) - Language



To set the language:

You are in the *User Configuration* (📖 p. 83)

1. Press on the submenu (1) Language.
 ↳ A list (2) holding the language selection opens:
2. Press on the desired language (3).
3. Restart the machine (📖 p. 15).
 ↳ The language of the control panel is changed.

Fig. 84: Setting the language (2)



(4) - Icon

When making changes to text, e.g. when changing program/sequence names (📖 p. 81), the user can switch to a different language using the integrated keyboard.



To switch the language on the integrated keyboard:

1. Press on the symbol (4) of the language selection.
 - ↳ You will be shown a language selection.
2. Select the desired language.
 - ↳ The language changes automatically.

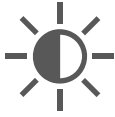

5.9.3 Adjusting the brightness

Here, you can adjust the brightness of the control panel.

Fig. 85: Adjusting the brightness

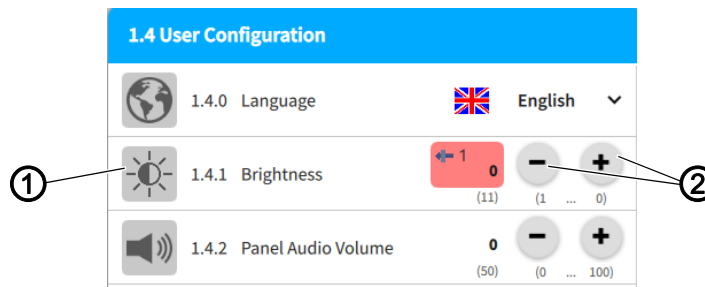

(1) - Brightness indicator

(2) - Buttons



To adjust the brightness:

You are in the *User Configuration* ( p. 83)

1. Go to the *Brightness* (1) display and enter the desired value using the buttons (2).
 - ↳ The brightness of the control panel is adjusted.



5.9.4 Adjusting the audio volume

Here, you can adjust the volume of the audio output.

Fig. 86: Adjusting the audio volume

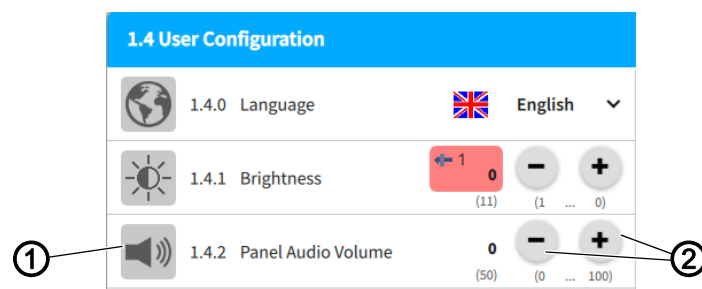

(1) - Audio volume indicator

(2) - Buttons



To adjust the audio volume:

You are in the *User Configuration* ( p. 83)

1. Go to the *Audio Volume* (1) display and enter the desired value using the buttons (2).
 - ↳ The volume of the control panel is adjusted.



5.9.5 Information

The *1.5 Information* display allows the currently logged-in user to read information about the software, the control, the control panel and the machine.



To access the information:



1. Press the symbol  to bring up the navigation pane.
 This opens the navigation user interface.

Fig. 87: Information (1)



(1) - Settings

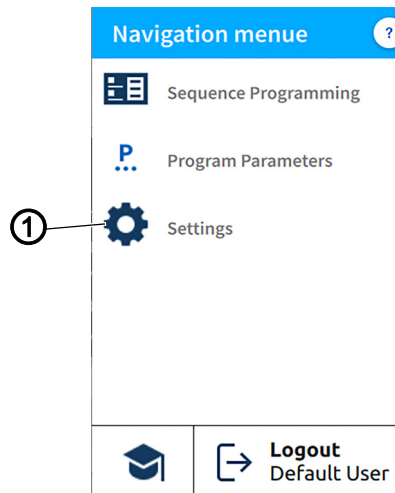

2. Press *Settings* (1).
 This opens the Settings user interface.

Fig. 88: Information (2)



(2) - Information
(3) - Symbols

(4) - Next page

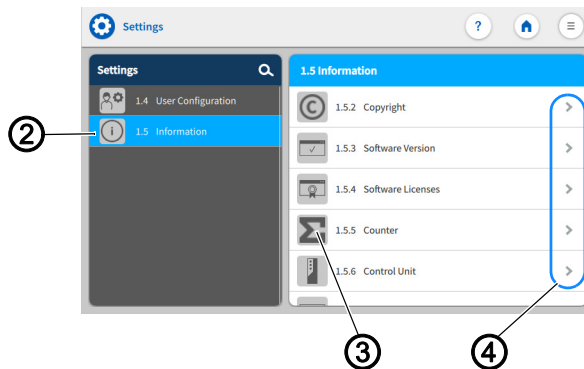









3. Press the option *Information* (2) on the left.
 You are on the Information screen. Displayed on the right side is a variety of symbols (3).

4. Next page (4)

↪ All information related to the symbol is displayed.







The symbols are listed and explained (3) in the table below.





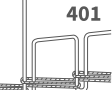

Icon	Menu item and explanation
	<i>1.5.2 Copyright</i> Dürkopp Adler GmbH
	<i>1.5.3 Software Version</i> Display of the software version for the touch panel and the machine control.
	<i>1.5.4 Software Licenses</i> Software license information.
	<i>1.5.5 Counter</i> Counts the number of cycles/programs since the initial installation of the machine.  Σ:0000 Machine life time counter: This counter cannot be reset.
	<i>1.5.6 Control</i> Control unit type and its serial number
	<i>1.5.7 Control panel Info</i> Show the information of the panel.
	<i>1.5.8 Machine</i> Show the information of the machine.



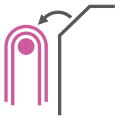
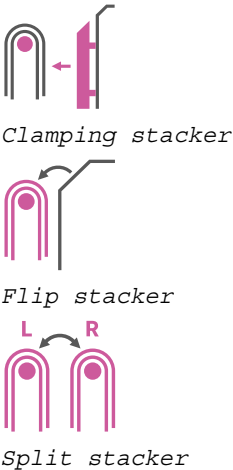







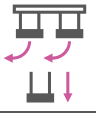

5.9.6 Machine Configuration

The *1.1 Machine Configuration* allows the user to change the configuration of the machine. They can define the additional equipment assembled to the machine and adjust it by turning it ON/OFF. The additional equipment enabled here affects the global parameters and the program parameters that can be selected and modified.

Selection	Setting 1	Setting 2
 1.1.1 <i>Class</i> Select the delivery state of the machine class.	 1.1.1.1 <i>Sewing unit for long closing seams</i>	1280 1281
	1.1.1.2 <i>Sewing head</i> Shows information about the machine	 EXT 1.1.1.2.4 <i>Pegasus EXT 3216</i>  EXT-H 1.1.1.2.5 <i>Pegasus EXT 3216H-Jeans</i>
	1.1.1.3 <i>Stitch type</i>	 401 2-thread chain stitch seam, Stitch type 401  515 4-thread safety seam, Stitch type 515  516 5-thread safety seam, Stitch type 516







Selection	Setting 1	Setting 2
 <p>1.1.2 <i>Stacker</i> For stacking trouser parts or other sewing material. Value range: ON/OFF</p>	<p><i>Stacker type</i> Select to display the list of stacker types.</p>	 <p><i>Clamping stacker</i></p> <p><i>Flip stacker</i></p> <p><i>Split stacker</i></p>
 <p>1.1.4 <i>Thread monitor</i> A classic chain thread monitor, the thread monitor is designed to monitor the thread during the sewing process. When detecting thread breakage, it stops the machine at the end of the seam.</p>		
<p>You can select up to 3 thread monitors:</p> <div style="display: flex; flex-direction: column; align-items: center;"> <div style="display: flex; align-items: center; margin-bottom: 10px;">  </div> <p>No thread monitor</p> <div style="display: flex; align-items: center; margin-bottom: 10px;">  </div> <p>1 thread monitor</p> <div style="display: flex; align-items: center; margin-bottom: 10px;">  </div> <p>2 thread monitors</p> </div>		
 <p>1.1.5 <i>Pneumatic edge guide, for manual fabric cutting</i> Edge guide, for trimming the edge of the fabric manually. Value range: ON/OFF</p>		



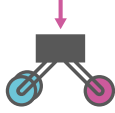

Selection	Setting 1	Setting 2
 <p>1.1.8 <i>Support Units</i> These are comprised of devices that provide support during sewing and stacking such as the puller/roll-out device, the swing out device/down holder or the down holder alone.</p>		 <p>Puller/roll-out device</p>  <p>Swing out device/ Down holder</p>  <p>Down holder</p>
 <p>1.1.12 <i>Thread tension release</i> The thread tension release is used to support the safe chain cutting when serging 3-thread seams. Value range: ON/OFF</p>		
 <p>1.1.13 <i>Laser marking lamp</i> Laser marking lamp for displaying and checking the course of the seam. Useful for sewing wing/side seam pockets in the area of the pocket opening at the bartack. Value range: ON/OFF</p>		
 <p>1.1.14 <i>Differential</i> Selection for differential top and bottom feed for fullness control via cylinder or stepper motor.</p>		 <p>1.1.14.1 <i>Cylinder</i></p>  <p>1.1.14.2 <i>Stepper motor</i></p>  <p>1.1.14.3 <i>Bottom feed with mechanical differential adjustment</i></p>





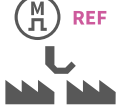

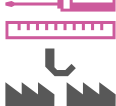
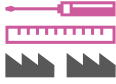























5.9.7 Service













Overview of the structure under 1.2 Service and its adjustments for services













Selection	Setting 1	Setting 2
 1.2.1 <i>Machine test</i> Enables the following test functions: Help roll (if available), Test puller / roll-out device (if available), Test stepper motors (if available) Test sewing drive/ motor, Test foot pedal (if available).	 1.2.1.3 <i>Test Puller/ Test roll-out device</i> Function test of the puller and the roll-out device	 1.2.1.3.1 <i>Lower the transport station</i> The puller (front) and the roll-out device (rear) are attached to the transport station. These are brought into position for their use when lowering. Value range: ON/OFF
		 1.2.1.3.2 <i>Lower the puller</i> Value range: ON/OFF
		 1.2.1.3.3 <i>Lower the roll-out device</i> Value range: ON/OFF
		 1.2.1.3.4 <i>Speed</i> Entering the speed of the puller/ unwinder Value range: 10-99 rpm
		 1.2.1.3.5 <i>Start puller/roll-out device</i> Start puller/unwinder at set speed Value range: ON/OFF





Selection	Setting 1	Setting 2
	 <p>1.2.1.6 Test differential stepper motors Test for the stepper motors for differential top and bottom feeds.</p>	 <p>1.2.1.6.1 Reference top differential feed ⓘ e.g. reference run for step- per motor (M2) NOT successfully performed. Check: 1. the proximity switch. 2. the distance to the reference switch. 3. the run of the stepper motor. ⚡OK</p>
		 <p>1.2.1.6.2 Reference bottom differential feed ⓘ Reference run for stepper motor (M1) successfully performed. ⚡OK</p>
		 <p>1.2.1.6.3 Calibration factor top feed Value range: 0-250</p>
		 <p>1.2.1.6.4 Calibration factor bottom feed Value range: 0-250</p>
		 <p>1.2.1.6.5 De-energize stepper motors Value range: ON/OFF</p>

Selection	Setting 1	Setting 2
		 <p>max</p> <p>1.2.1.6.7 Maximum position of differential bottom feed Value range: 10-250</p>
		 <p>max</p> <p>1.2.1.6.8 Maximum position of differential top feed Value range: 10-250</p>
	 <p>1.2.1.7 Test sewing drive</p>	 <p>1.2.1.7.1 Needle position UP/DOWN</p>
		 <p>1.2.1.7.2 Speed Enter the speed for the sewing motor test. Value range: 100-6500 rpm</p>
		 <p>1.2.1.7.3 Start sewing drive Start sewing drive. Value range: ON/OFF</p>
	 <p>1.2.1.8 Test foot pedal - Manual sewing Function test of the foot pedal for manual sewing.</p>	 <p>Foot pedal position Select to view foot pedal position. ☞ Foot pedal position is displayed</p>

Selection	Setting 1	Setting 2
 <p>1.2.2 Multitest</p>	 <p>1.2.2.1 Test input Allows the user to test the incoming signals. E.g. the function of the light barriers, photocells, etc.</p>	 <p>1.2.2.1.1 Grid view Select one / multiple functions in grid view. ↳ All functions are executed once at the same time.</p>  <p>1.2.2.1.2 Reset ↳ The grid is empty.</p>  <p>Press ↳ Display of grid view returns to list view</p>
	 <p>1.2.2.2 Test output Allows the user to test the outgoing signals. E.g. the function of the sewing foot lift, pedal, sword, etc.</p>	<p>List View:</p>   Y01 Sewing foot  Y02 Thread tension  Y03 Contour guide.
		 Y04 Stacker  Y05 Down holder  Y05 Puller/Down holder  Y07 Roll-out device  Y08 Contour guide blowing
		 Y10 Differential bottom feed  Y11 Differential top feed  Y12 Vacuum chain cut  Y13 Table blowing  Y14 Waste suction

Selection	Setting 1	Setting 2
		 Y17 Edge guide  Y18 Transport unit  Y19 Contour guide Move sideways  Y20 Move contour guide forwards and backwards
		 Y21 Mouse station back  Y26 Move stacker table sideways  Laser marking lamp Value range: ON/OFF ↳ Function is selected/deselected directly in the grid.
		 <p>1.2.2.2.1 Grid view Select one / multiple functions in grid view. ↳ All functions are executed once at the same time.</p>  <p>1.2.2.2.4 Auto on ↳ All functions are repeated continuously at the same time.</p>  <p>1.2.2.2.2 Reset ↳ The grid is empty again.</p>  <p>Press ↳ Display of grid view returns to list view</p>
	 <p>1.2.2.3 RAM test Memory chip analysis. E.g. to identify a defective RAM module.</p>	 RAM test result E.g. reference run for stepper motor (M1) successfully performed. ↳ OK





Selection	Setting 1	Setting 2
	 ROM 1.2.2.4 <i>ROM test</i> Memory chip analysis. E.g. of the read-only memory.	 ROM test result E.g. reference run for stepper motor (M1) successfully performed.  OK
INIT 1.2.3 <i>Initialise</i> Initialize the data to the default values.	INIT  1.2.3.1 <i>Init global parameters</i>	Kindly confirm initialisation!  All the global parameters will be reset to factory default and cannot be recalled! Or: Cancel
	INIT  1.2.3.2 <i>Init sequences</i>	Kindly confirm initialisation!  All the sequences will be reset to factory default and cannot be recalled. Created sequences will be overwritten. Or: Cancel
	INIT P... 1.2.3.3 <i>Init sewing programs</i>	Kindly confirm initialisation!  All the parameters of Sewing programs will be reset to factory default and cannot be recalled! Or: Cancel
	INIT  1.2.3.4 <i>Master init</i>	Kindly confirm initialisation!  All Global parameters, Sequences and Sewing programs will be reset to factory default and cannot be recalled! Or: Cancel
	INIT  1.2.3.5 <i>Init machine configuration</i>	Kindly confirm initialisation!  All machine configurations will be reset to factory default and cannot be recalled. Created configurations will be overwritten. Or: Cancel



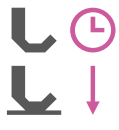
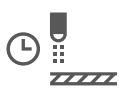

Selection	Setting 1	Setting 2
	 1.2.3.6 <i>Remove User Tutorials</i>	Confirm: Remove User Tutorials.  All User Tutorials will be removed. Or: Cancel
	 1.2.3.7 <i>Remove vendor tutorials</i>	Confirm: Remove vendor tutorial.  All vendor tutorials sets by default will be deleted. Or: Cancel
 1.2.5 <i>Logging</i> Sub menu of Logging	Filter: All levels Debug Warning notice Assert Export	Type to search...



GP

5.9.8 Global parameters



The global parameters allow the user to set/adjust parameters that apply to all programs. The following tables provides an overview of the structure of the *1.3 Global Parameters* (they are valid for all programs).

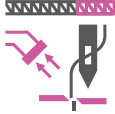

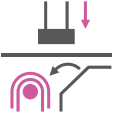
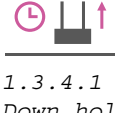
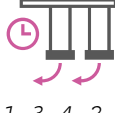

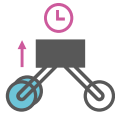
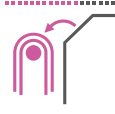
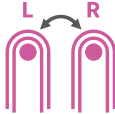
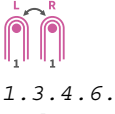
Selection	Setting 1	Setting 2
 1.3.1 Light barrier Select to view photo cell menu	 1.3.1.2 Delay to lower the sewing foot The delay for lowering the presser foot after light barrier detection facilitates material feed under the presser foot.	Default: 0.2 Sec. Value range: 0.00-1.00 Sec.
	 1.3.1.3 Automatic sewing start delay Delay for automatic sewing start, for secure positioning of the sew- ing material under the presser foot.	Default: 0.1 Sec. Value range: 0.00-5.00 Sec.
	 1.3.1.4 Delay of sewing foot lift after seam end The delay of the sewing foot lift at the seam end ensures that the thread chain cutting works safely.	Default: 0.2 Sec. Value range: 0.00-1.00 Sec.
 1.3.2 Thread ten- sion release The thread tension release is used to support the safe chain cutting when serging 3-thread seams.	 1.3.2.1 Thread tension release at the seam beginning	Default: Off Value range: ON/OFF





Selection	Setting 1	Setting 2
	 <p>1.3.2.2 <i>Seam section with thread tension release in cm at the seam beginning</i> Enter the seam section (in cm) for the thread tension release at the seam beginning. This is used to support safe chain cutting when serging 3-thread seams.</p>	<p>Default: 0 cm Value range: 0-10 cm</p>
	 <p>1.3.2.3 <i>Thread tension release at the end of the seam</i></p>	<p>Default: ON Value range: ON/OFF</p>
	 <p>1.3.2.4 <i>Seam section with thread tension release in cm at the end of the seam</i> Enter the seam section for thread tension release at the end of the seam. This is used to support safe chain cutting when serging 3-thread seams.</p>	<p>Default: 3.00 cm Value range: 0-10 cm</p>
 <p>1.3.3 <i>Thread chain cut</i> Setting the parameters for optimum thread chain cut</p>	 <p>1.3.3.1 <i>Sewing speed during thread chain cut.</i> Reduced sewing speed during thread chain separation to reduce wear parts.</p>	<p>Default: 4000 rpm Value range: 200-5000 rpm</p>

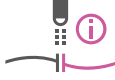

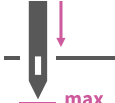

Selection	Setting 1	Setting 2
	 <p>1.3.3.4 <i>Distance until the start of suction for the chain cut at the end of the seam</i> The seam section up to the beginning of the suction for the chain cut at the seam end influences the safe thread chain cutting.</p>	<p>Default: 1.00 cm</p> <p>Value range: 0.0-10.0 cm</p>
	 <p>1.3.3.5 <i>Seam section with suction for the chain cut</i> The seam section with the suction for the chain cut at the seam beginning ensures a clean, short chain at the material beginning.</p>	<p>Default: 2.00 cm</p> <p>Value range: 0.0-10.0 cm</p>
 <p>1.3.4 <i>Stacker/down holder/roll-out device</i> Adjusting the parameters for optimum functioning of the stacker and the down holder.</p>	 <p>1.3.4.1 <i>Down holder lift delay after...</i> The delay for lifting the down holder after the stacker has clamped the material is used to transfer the material into the stacker without sliding off from the tabletop.</p>	<p>Default: 0.30 Sec.</p> <p>Value range: 0.10-3.00 Sec.</p>
	 <p>1.3.4.2 <i>Time until swing out device swings back</i> Waiting time until the swing out device swings back - after sewing stop. This time is helpful when reloading sewing pieces for which the swing out device is to stop at the sewing head.</p>	<p>Default: 1.00 Sec.</p> <p>Value range: 0.00- 5.00 Sec.</p>

Selection	Setting 1	Setting 2
	 <p>1.3.4.3 <i>Stacker clamping time</i> The stacker clamping time ensures that the material is safely held and stacked.</p>	<p>Default: 0.8 Sec. Value range: 0.10-3.00 Sec.</p>
	 <p>1.3.4.4 <i>Roll-out device</i> <i>Delay time</i> Input of the delay time for lifting the roll-out device after rolling out into the stacker, before taking over the stacker.</p>	<p>Default: 0.3 Sec. Value range: 0.10-3.00 Sec.</p>
	 <p>1.3.4.5 <i>Minimum sewing length for stacking</i> Enter the minimum seam length before the stacking process is to take place.</p>	<p>Default: 20 cm Value range: 20 - 100 cm</p>
	 <p>1.3.4.6 <i>Stacker mode for separating</i> For separating trouser parts right/left or for large storage of several bundles.</p>	 <p>1.3.4.6.1 <i>Mode 1: Right/left alternately</i> Right/left alternately separates the bundle of trousers into right and left portions. Value range: ON/OFF</p>

Selection	Setting 1	Setting 2
		 <p>1.3.4.6.2 Mode 2: Switch to other side after X parts Allows for a fixed number of stacked parts for the right and the left side of the stacker. Value range: ON/OFF</p> <p>1.3.4.6.2.1 Separating the parts after stacking Number of parts after which the separation of the parts is supposed to take place. Default: 10 Pieces Value range: 1-200 Piece(s)</p>
		 <p>1.3.4.6.3 Mode 3: Manual switch from right/left A switch of the stacker position can only be performed with a press of the: Manual switch button. Value range: ON/OFF</p>
		 <p>1.3.4.6.4 Mode 4: Setting program-related Setting program-related means that the stacker setting can be stored separately for each selected program. Value range: ON/OFF</p>

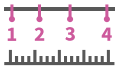
Selection	Setting 1	Setting 2
 <p>1.3.5 <i>Thread monitor</i> The thread monitor is used to detect thread breakage</p>	 <p>1.3.5.1 <i>Thread monitor</i> The thread monitor detects a thread breakage and stops the sewing process. Value range: ON/OFF</p>	 <p>1.3.5.2 <i>Thread monitor sensitivity</i> Thread monitor sensitivity is used to adjust to different yarns / colors to detect faulty material. Default: 50 Value range: 0-100</p>
	 <p>1.3.5.4 <i>Seam length until thread monitor info active</i> Seam length until thread monitor info is activated to avoid faulty detection at the beginning of the seam, which can be caused by thread loops.</p>	<p>Default: 2.0 Value range: 0.0 - 10.0 cm</p>
	 <p>1.3.5. <i>Sewing speed with thread monitor activated</i> Sewing speed when the thread monitor is activated. When the thread monitor is activated, a certain sewing speed can be set from which the thread monitor is active.</p>	<p>Default: 3000 rpm Value range: 100-5500 rpm</p>
 <p>1.3.6 <i>Needle position at bottom dead center</i> This refers to the needle position at the bottom dead center. Default: 180° Value range: 0-360°</p>		

Selection	Setting 1	Setting 2
 <p>1.3.7 <i>Stitch length</i> Input of the mechanically adjusted stitch length to calculate all dependent parameters in the control. Default: 2.7 mm Value range: 1.0 - 3.5 mm</p>		
 <p>max</p> <p>1.3.8 <i>Speed</i> Input of the maximum speed for the main seams and for manual sewing via pedal. Varies with the installed sewing head.</p>	 <p>max</p> <p>1.3.8.1 <i>Max. speed in main seam</i> Setting the maximum allowed sewing speed for the main seams - over all programs.</p>	<p>Sewing head EXT Default: 6500 rpm Value range: 100-6500 rpm</p> <p>Sewing head EXT-H Default: 5500 rpm Value range: 100-5500 rpm</p>
	 <p>max</p> <p>1.3.8.2 <i>Max. speed for manual sewing via pedal</i> Setting the maximum allowed sewing speed for the main seams - over all programs.</p>	<p>Sewing head EXT Default: 6500 rpm Value range: 100-6500 rpm</p> <p>Sewing head EXT-H Default: 5500 rpm Value range: 100-5500 rpm</p>
 <p>1.3.12 <i>Sewing foot lifting at seam beginning/end</i> For safe feeding and sewing of the material at the seam beginning, the "presser foot position lifted" is recommended. Default: UP Value range: UP/DOWN</p>		

Selection	Setting 1	Setting 2
 <p>1.3.13 <i>Reference dimension</i> The reference dimension is used to distribute the fullness within a seam</p>	 <p><i>Reference dimension</i> When the reference dimension is active, each dimension is referenced to the starting point of a seam.</p>	
 <p>1.3.14 <i>Needle position at seam end Up</i> For safe feeding and sewing of the material, the "needle position at seam end DOWN" is recommended. If pieces of material are serged without the seam chain running out, the "needle position at seam end UP" is necessary. For this, it is necessary to define the parameter under Needle position at bottom dead center (see 1.3.6 ). Default: DOWN Value range: UP/DOWN</p>		
 <p>1.3.15 <i>Time to pull back the mouse station</i> Time in seconds to activate the cylinder for the mouse station. This pulls the mouse station back to its start position. Default: 2.0 Sec. Value range: 0 - 8 Sec.</p>		





5.9.9 Software update

The *1.6 Software Update* allows the user to update the software of the control unit. To do this, follow the instructions in the corresponding chapter ( p. 168).



Follow the order for control panel and control when performing the software updates:







1. Perform the update for the control panel ( p. 168).
2. Perform the update for the control ( p. 170).





Selection	Setting 1	Setting 2
<i>System Update</i>	Select an update file	





5.9.10 Manual data transfer

The following table provides an overview of the structure of the 1.7 Manual Data Transfer.

Selection	Setting 1	Setting 2
 1.7.1 <i>Export</i> Adjustments of the data transfer (p. 160)	 1.7.1.1 <i>Programs</i> With this function the sewing programs available on the machine are exported.	1. Choose export destination, e.g.: USB port ↳ Next 2. Select/activate single/multiple programs. ↳ Export 3. Transfer of the file to the USB port complete
	 1.7.1.2 <i>Sequences</i> This function allows to export sequences and their connected programs for import on another machine.	(see above Setting 2: Export programs)
	 1.7.1.3 <i>Global Parameters</i> Allows to export Global Parameters.	(see above Setting 2: Export programs)
	 1.7.1.4 <i>Machine Configuration</i> Allows to export Machine Configuration.	(see above Setting 2: Export programs)
	 1.7.1.5 <i>Log files</i> This function exports the log files available on the machine.	(see above Setting 2: Export programs)

Selection	Setting 1	Setting 2
	 1.7.1.6 <i>Customer Multimedia</i> This function exports official media files from the vendor.	(see above Setting 2: Export programs)
	 1.7.1.7 <i>Vendor Multimedia</i>	(see above Setting 2: Export programs)
 1.7.2 <i>Import Settings for importing data</i> (📖 p. 163).	P... 1.7.2.1 <i>Programs</i> With this function sewing programs are imported.	1. Choose import source e.g.: USB port ↵ Next 2. Select/activate single/multiple programs. ↵ Import 3. The import of the following files will overwrite existing programs where necessary Transfer complete Or press: Cancel
	 1.7.2.2 <i>Sequences</i> This function allows to import sequences and their connected programs.	(see above Setting 2: Import programs)
	 1.7.2.3 <i>Global Parameters</i> Imports settings from Global Parameters which had been exported before.	(see above Setting 2: Import programs)



Selection	Setting 1	Setting 2
	 <p>1.7.2.4 <i>Machine Configuration</i> Imports settings from Machine Configuration which had been exported before.</p>	(see above Setting 2: Import programs)
	 <p>1.7.2.5 <i>Customer Multimedia</i> This file imports media files.</p>	(see above Setting 2: Import programs)
	 <p>1.7.2.6 <i>Vendor Multimedia</i> This function imports official media files provided by the vendor.</p>	(see above Setting 2: Import programs)

5.9.11 Searching settings

When on the *Settings* user interface, the user can search for specific settings.



To access the *Search settings* function:

1. Press on the symbol .
 - ↳ This calls up the user interface with a search field, the parameter list, and an integrated keyboard.
 - You can enter the setting you are looking for using the keyboard.
 - You can select a setting directly by scrolling.
 - ↳ The parameter list shows the parameters related to the corresponding setting. You can change these settings individually.
2. Press *Close*.
 - ↳ The adjusted settings are stored, and the display returns to the previous user interface.
3. To exit *Search settings*, press .
 - ↳ The *Settings* user interface opens.

5.10 Tutorials

The Tutorials menu contains instructions in the form of videos or PDF files, which have been uploaded by the manufacturer.



To access the tutorials:

1. Press the symbol  to bring up the navigation pane
 - ↳ This opens the navigation user interface.

Fig. 89: Tutorial (1)



(1) - Tutorial

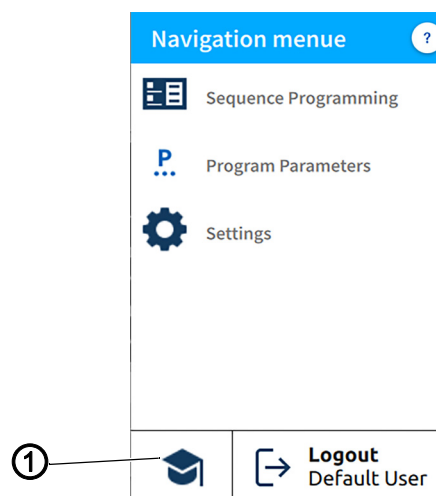

2. Press *Tutorial* (1).
- ↳ The *Tutorial* (2) user interface opens.

Fig. 90: *Tutorial* (2)

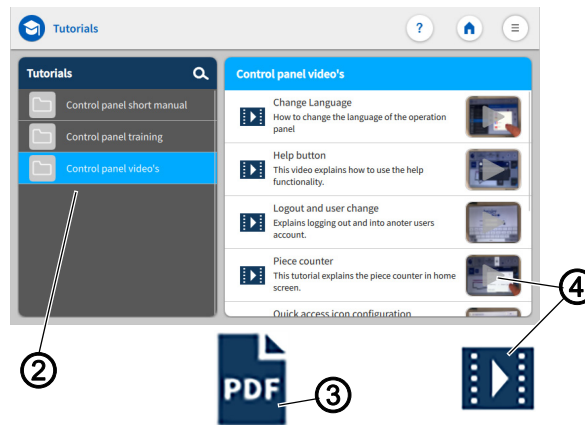

- (2) - *Tutorials*
(3) - *PDF*

- (4) - *Video*



3. Select an option in the *Tutorials* (2):
 - Control panel videos
 - Control panel short manual PDF file
 - Control panel training PDF file
- ↳ A selection appears on the right:
 - Videos (4)
 - PDF files (3).
4. Select Desired video(4)/Desired PDF file (3).
- ↳ The video (4)/PDF file (3) is uploaded.
5. Watch the video pressing Start and Stop.
- ↳ Press the arrow at the top left to return to the *Tutorials*.
6. View the PDF file by swiping up and down.
- ↳ Press x at the top right to return to the *Tutorials* (2).

5.11 Login/Logout



To access Login/Logout:

1. Press the symbol  to bring up the navigation pane.
- ↳ This opens the navigation user interface.

Fig. 91: Login/Logout



(1) - Logout

(2) - Login user interface

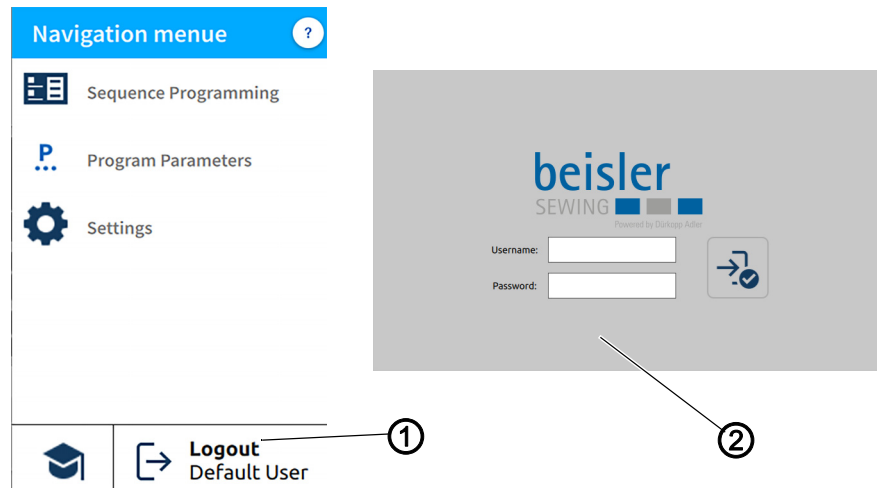

2. Press *Logout* (1).
- ↳ This opens the Login user interface (2).



Information

If logged out, the user can log back into the system at any time by entering the username: *user* (no password required).

There are two login options. You can toggle between the *Default User* and the *Technician* user level:

- **Username:** *user* **Password:** -
- **Username:** *technician* **Password:** *25483*

Login with username and password

To log in with username and password:

1. Enter *username* and *password*.
2. Press on the symbol .
- ↳ If the login information is correct, the user will be logged in.

5.12 Software operating modes





The software of the Commander Pro control panel offers various operating modes:









1. Piece counter
 - The display of the piece counter corresponds to the counting settings and shows how many times a program or a selected number of programs is executed.
2. Program Parameters
 - A program is composed of various parameters.
 - Each program includes a graphical representation of the seam, the sewing graphics.
3. Sequence Programming
 - At least one program is required.
 - A sequence consists of a specific sequence of programs.
 - The program sequence can be configured to individual requirements.
4. Quick access panel
 - The quick access tiles can be used to directly adjust settings and values of the program parameters.
 - The quick access panel is composed of an arrangement of customized tiles on the start screen.
 - The quick access tiles are sequence-specific and customized to fit the program sequence.

The individual operating modes and their uses are explained in detail later on.

5.12.1 Buttons in the operating modes

Managing the operating modes is quick and easy thanks to the buttons listed below

Icon	Description
	Switch ON
	Switch OFF
	Templates Select for overwriting programs.
	Copy from...
	Search for...

Icon	Description
	Reset to standard/default factory setting
	Switch from the <i>Sequence selection</i> to <i>Sequence Programming</i> .
	Switch from <i>Sequence Programming</i> to <i>Quick Access</i> .
	Add
	Delete
	Back to previous page.
	Close
	Active
	Inactive

5.13 Piece counter

Fig. 92: Piece counter

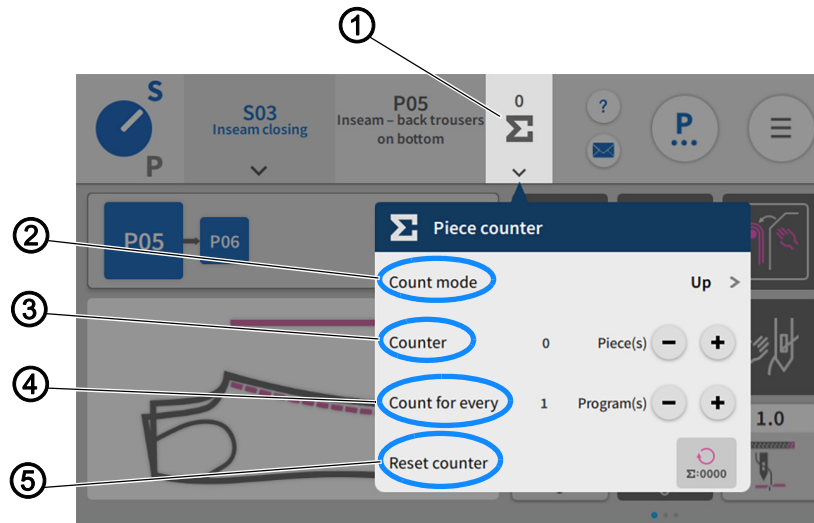

- (1) - Piece counter
- (2) - Counting Mode
- (3) - Counter
- (4) - Count for every __ programs
- (5) - Reset counter



To access the counter setting:

1. Press on the symbol found on the tile of the piece counter (1) in the status bar.
- ↳ A window opens that lets you adjust the advanced settings of the piece counter.

Settings for the piece counter

Setting	Explanation
Count mode (2) ↳ Press on the symbol:	Up: the user can set the counter to counting up. Down: the user can set the counter to counting down. Off: the user can switch the counter off.
Counter (3)	The counter can change the counter result using the corresponding buttons (+/-). Or, you can enter the desired number directly.
Count for every (4) __ programs	The user can decide after how many programs the count mode Up/Down is supposed to be set = count sequence mode. Change with the button (+/-). Example: Count for every 2 programs = the value is counted up as soon as 2 programs have been sewn.
Reset counter (5) Σ:0000	Count mode Up: The counter value is reset to 0. Count mode Down: The counter value is reset to 1.



5.14 Program parameters

The machine contains 200 programs.



Information

A program cannot be deleted; it can only be added to or removed from a sequence.

Every program is linked to a template. The template contains the factory settings, predefined parameters and the corresponding sewing graphics.

When being assigned to a program, a template resets all previous parameters in the corresponding program and also changes the sewing graphics in accordance with the template.

5.14.1 User interface Program parameters

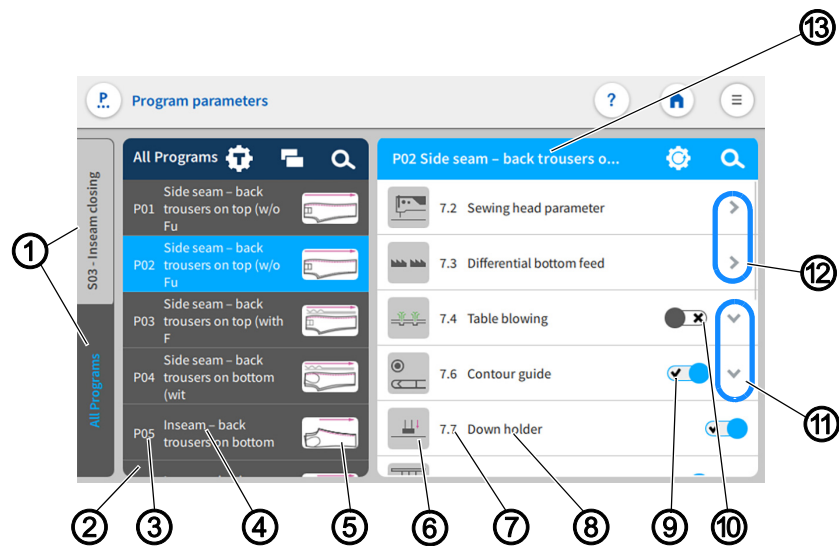

Fig. 93: User interface Program parameters (1)



- | | |
|------------------------|--|
| (1) - Tab | (7) - Parameter number |
| (2) - Program list | (8) - Parameter name |
| (3) - Program number | (9) - Parameter: ON |
| (4) - Program name | (10) - Parameter: Off |
| (5) - Sewing graphics | (11) - Go to submenu |
| (6) - Parameter symbol | (12) - Scroll one page forward for the submenu |
| | (13) - Program number and description |



To access the function *Program parameters*:

- Press the symbol  on the main page.
- Go to the navigation menu and press the  symbol.



- If the user is in the user interface *Sequence Programming*, press the symbol (14) .

Fig. 94: User interface Program parameters (2)

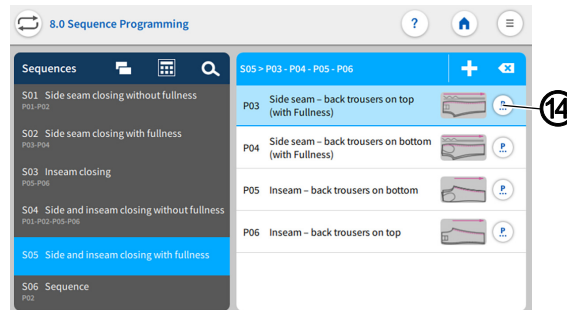

(14) - Icon

- ↳ The corresponding user interface for the program parameters ( p. 115) opens

5.14.2 Current Sequence/Current Program

Fig. 95: Current Sequence/Current Program (1)

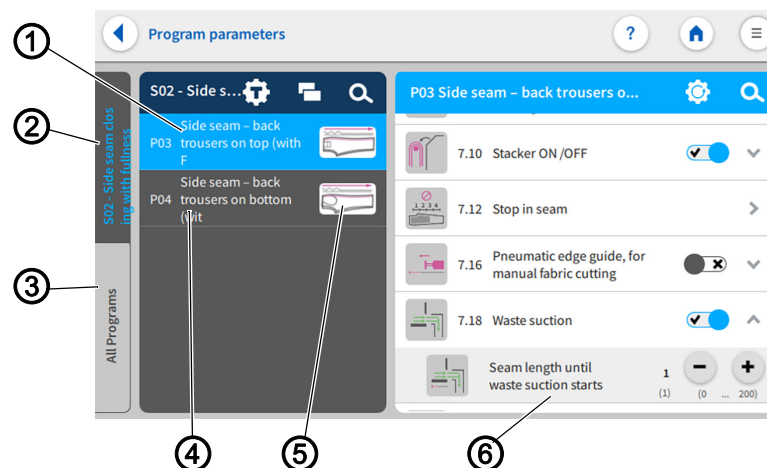

- (1) - Program
- (2) - Sequence
- (3) - All programs
- (4) - List
- (5) - Sewing graphics
- (6) - List

You can toggle between the tabs Sequence (2) and All Programs (3). The user can always tell which tab is active by the blue font placed against the dark background.

The tab: Sequence (2) is active. All programs included in this sequence are shown on the list (4). All parameters have been stored on this list (6) and can be configured individually to match the program (1). The view of the sewing graphics (5) has been included from the corresponding template of the program and is contained in every program.

Fig. 96: Current Sequence/Current Program (2)

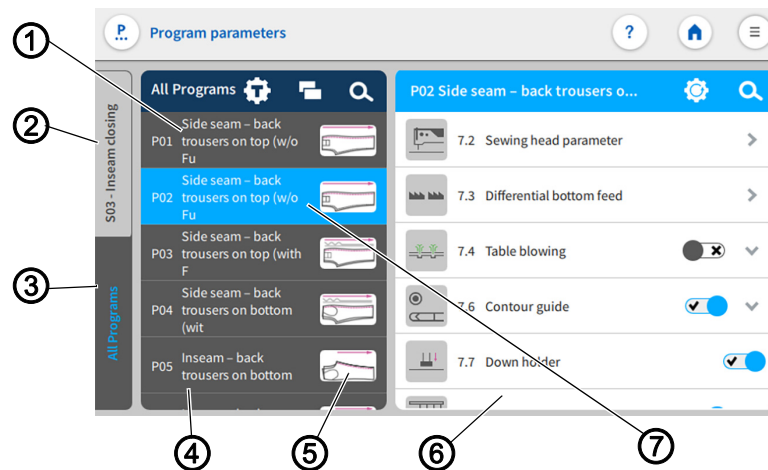

- | | |
|--------------------|-----------------------|
| (1) - Program | (4) - List |
| (2) - Sequence | (5) - Sewing graphics |
| (3) - All programs | (6) - List |
| | (7) - Active |

If the tab: All Programs (3) is active, the list (4) shows all 200 available programs (1) including the sewing graphics (5).

If the sequence/program name is active (7), you can change the name with a double click (📖 p. 80).



Information

The sewing graphics (5) can only be changed by modifying the program template (📖 p. 117).

5.14.3 Program templates

There are 7 preconfigured sewing programs available. They either enable a direct sewing start or serve as a template for modification according to customer requirements:

- Templates T01 are T04 are preconfigured, ready-to-sew programs for closing the side seams.
- Templates T05 are T06 are preconfigured, ready-to-sew programs for closing the inseams.
- Template T07 is designed for straight seams, such as those found in bed sheets.



To access the program templates:

1. Open the user interface *Program parameters* and press the  symbol.
- ↪ The user interface for the program templates opens.

Fig. 97: Program templates



- (1) - Straight seams
(2) - Inseam closing
(3) - Side seam closing

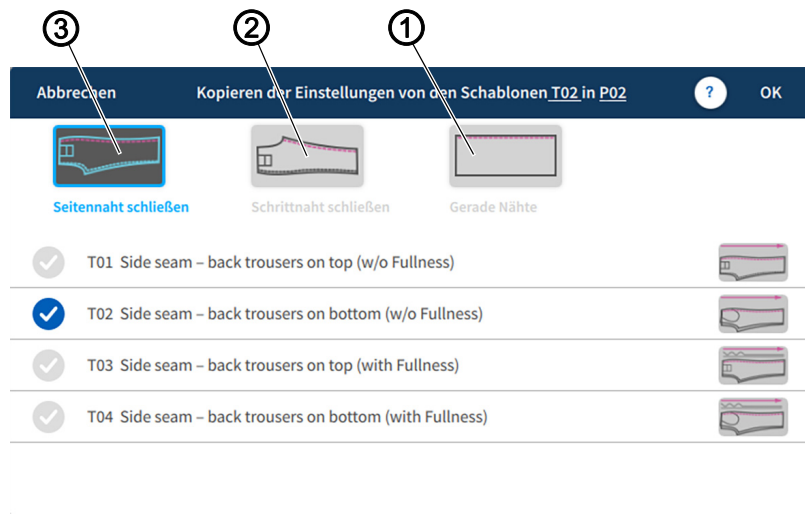

Tab for selecting the templates for Side seam closing (3), Inseam closing (2), and Straight seams (1).

Copy settings from a template of different program to the active program.

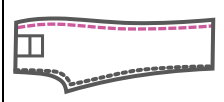
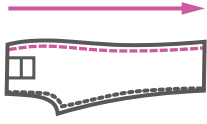
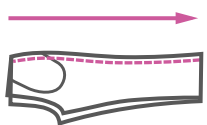
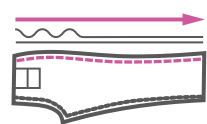
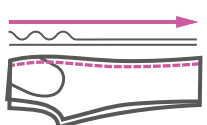
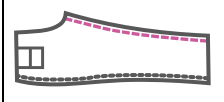
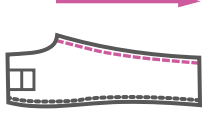
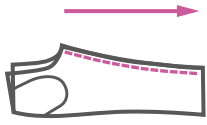

2. Press the desired template (1), (2) or (3).
 - ↪ A list with variants opens.
3. Activate the desired variant with a press of the symbol.
4. Press *OK*.
 - ↪ A warning notices appears reading *All the parameters & names of the program would be changed to template default and cannot be recalled!*
5. Press *Cancel* or *Change Template*.
 - ↪ *Cancel*: The display returns to the previous user interface.
 - ↪ *Change Template*: The user is prompted to confirm to proceed.

Overview of templates and variants

Template	Variant	Explanation
 <p>Side seam closing</p>		<p>T01 Side seam Back trouser on top Without fullness</p>
		<p>T02 Side seam Back trouser at bottom Without fullness</p>
		<p>T03 Side seam Back trouser on top With fullness</p>
		<p>T04 Side seam Back trouser at bottom With fullness</p>
 <p>Inseam closing</p>		<p>T05 Inseam Back trouser on top</p>
		<p>T06 Inseam Back trouser at bottom</p>
 <p>Straight seams</p>		<p>T07 Straight seams e.g. bedding, comforters, pillows</p>

5.14.4 Copying program parameters

This option allows the user to copy the program parameters of one program to multiple programs. The copy contains parameters and sewing graphics as well as all program-related data.



Information

The grid view contains a color indication for the programs. This color indication can help with the selection of the programs (see table Color indicators in grid view).

Color indicators in grid view

P44	Used in one/multiple sequences
P01	User in the current sequence
P43	Modified, but not used in any sequence.
P42	Not modified and not used.

Fig. 98: Copying program parameters (1)

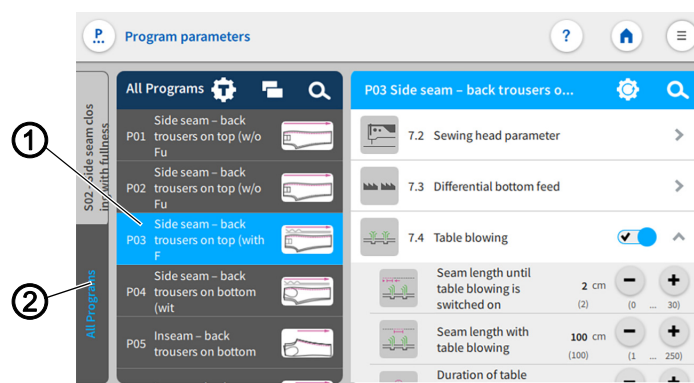

(1) - Program

(2) - Active tab



To copy parameters:



1. Press the program (1) you wish to copy in the active tab (2) *All Programs*.
- ↪ The program (1) is activated.
2. Press on the symbol .
- ↪ A user interface opens showing the program overview with all 200 programs in grid view (4).
- ↪ In grid view (4), only the program number (5) is visible (see table Color indicators in grid view).

Fig. 99: Copying program parameters (2)

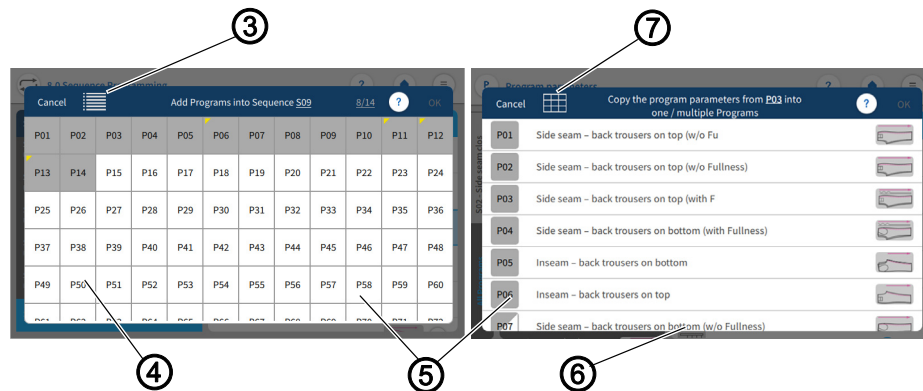

(3) - Symbol List View
(4) - Grid view

(5) - Program number
(6) - List view
(7) - Symbol Grid View



3. The symbol List View (3) allows the user to switch to list view.
- ↪ The list view (6) shows the program number (5), the name and the sewing graphics.
4. The symbol List View (7) allows the user to return to grid view (4).
5. Select one/multiple programs (5) and press *OK*.
- ↪ A warning notice reading  *Kindly confirm Copy!* appears. *All parameters and names of the program(s) would be changed as per program (e.g. P51) and cannot be recalled!*
6. Press *Cancel/Copy Parameters*.
- ↪ *Cancel*: the user returns to the user interface *Program parameters*.
- ↪ *Copy Parameters*: a warning notice appears reading  *Copied- Successfully Copied*.
7. Confirm with *OK*.
- ↪ The parameters have been copied.

5.14.5 Search

The user can search for specific program numbers or program names.



To access the Search function:

1. Select the tab *All Programs*.
 - ↪ This opens the user interface containing all 200 programs.
2. Press on the symbol .
 - ↪ A user interface opens containing a search field, the parameter list and an integrated keyboard.
 - You can use the keyboard to enter the program name/program number ( p. 80).
 - You can select a program directly by scrolling.
 - ↪ The parameter list shows the parameters that are related to the corresponding program and can be altered individually.
 - ↪ Press *Close*.
 - ↪ The adjusted settings are stored, and the display returns to the previous user interface.
3. Exit the parameter search with a press of .
 - ↪ The user interface *Program parameters* opens.

5.14.6 Resetting program parameters



Important

The action of resetting the parameters cannot be reverted! The reset is always preceded by a warning notice.



To access the function Reset program parameters.

1. Press on the symbol .
 - ↪ This opens the user interface including a warning notice.

Fig. 100: Resetting program parameters

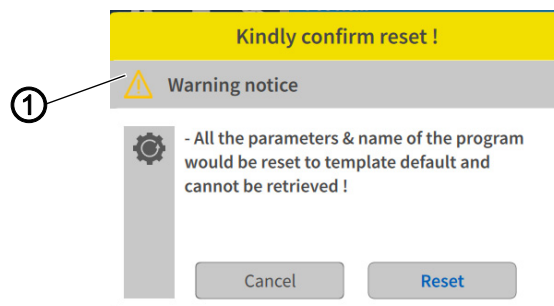

(1) - Warning notice

The warning notice (1) appears prior to the reset.

2. Press *Reset*.
- ↳ The program parameters are reset to the associated template.
3. Press *Cancel* .
- ↳ The process is canceled.

5.14.7 Program parameter search



To access the function Program parameter search:

1. Press on the symbol .
- ↳ The user interface containing the program list, the search field and an integrated keyboard open.
- Use the keyboard to type in the parameter name or the parameter number.
- You can select a parameter directly by scrolling.
- ↳ The parameter list shows the parameters matching the corresponding program, and you can change the settings to your individual requirements.
2. Press *Close*.
- ↳ The adjusted settings are stored, and the display returns to the previous user interface.



5.14.8 Adjusting the program parameters









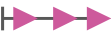
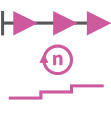
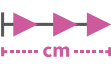

Important









The set program parameters always apply to the currently selected program only.



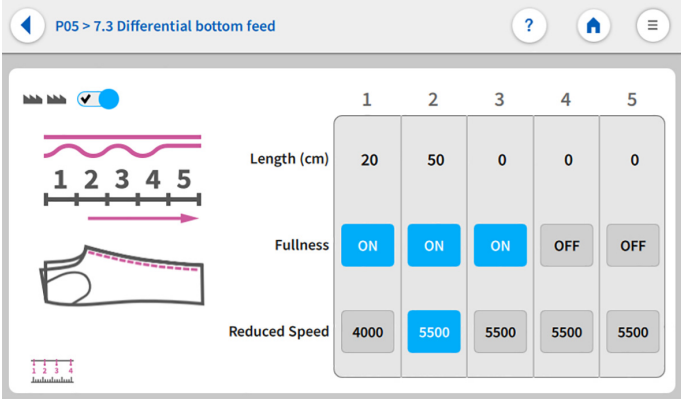

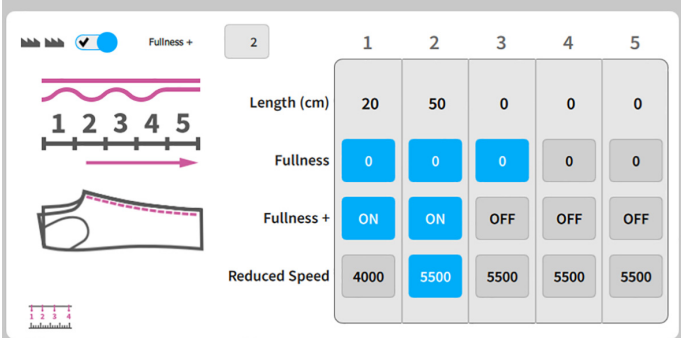



There are various options for setting the program parameters. The following table lists all possible options.





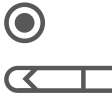











Symbol/parameter	Submenu/setting
 7.2 <i>Sewing head parameter</i> Parameters for adjusting the sewing head, e.g. sewing speed, soft start, chain cutting, sewing start mode, etc.	 7.2.1 <i>Sewing speed</i> Setting the sewing speed for the selected program. Default: 5500 rpm Value range: 100-5500 rpm
	 7.2.2 <i>Soft start</i> Setting the sewing speed at the seam beginning as soft start, for safe sewing start. Value range: ON/OFF Other setting options:  7.2.2.2 <i>Softstart sewing speed</i> Setting the sewing speed for the soft start. If the speed is set too high, safe sewing is not guaranteed. Default: 3000 rpm Value range: 100-4000 rpm
	 7.2.2.3 <i>Softstart sewing length</i> Setting the seam length of the soft start in cm. Default: 3.00 cm Value range: 0-10.0cm







Symbol/parameter	Submenu/setting
	<div style="text-align: center;">  </div> <p>7.2.3 <i>Chain cut</i> Parameter for setting the chain cut length at the seam end Value range: ON/OFF</p> <p>Other setting options:</p> <div style="text-align: center;">  </div> <p>7.2.3.1 <i>Length of chain at seam end</i> Adjust the required chain length at the seam end. This depends on the material. Default: 1.00cm Value range: 0.00-10.00 cm</p> <div style="text-align: center;">  </div> <p>7.2.3.2 <i>Overrun length after seam end for safe chain cut</i> Setting the sewing length until the chain cut is activated. Default: 3.50cm Value range: 1.00-20.00cm</p>



Symbol/parameter	Submenu/setting
	 <p>7.2.6 <i>Start Mode</i> Value range: ON/OFF</p> <p>Other setting options:</p>  <p>7.2.6.1 <i>Start mode 1: Automatic sewing start by light barrier</i> Fully automatic sewing start via light barrier recognition Value range: ON/OFF</p>  <p>7.2.6.2 <i>Start mode 2: Manual sewing start by foot pedal</i> Manual sewing start/Manual sewing via pedal, then activate the automatic sewing start after xxxx cm. Value range: ON/OFF</p>  <p>7.2.6.3 <i>Start mode 3:</i> 1.manual sewing start, 2.contour guide, 3.automatic sewing start by foot pedal. Manual sewing start/Manual sewing via pedal, then press pedal to activate automatic sewing start. Value range: ON/OFF</p>  <p>7.2.6.6 <i>Sewing length until automatic sewing start</i> Setting the seam length in cm until automatic change to automatic sewing start. Value range: 0-100 cm</p>

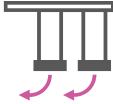





Symbol/parameter	Submenu/setting																														
 <p>7.3 <i>Differential bottom feed</i> The entire seam can be divided in up to 5 seam sections. Parameters can be set independently for each section. Value range: ON/OFF</p>	 <p>Cylinder view</p>  <table border="1" data-bbox="1038 577 1377 846"> <thead> <tr> <th></th> <th>1</th> <th>2</th> <th>3</th> <th>4</th> <th>5</th> </tr> </thead> <tbody> <tr> <td>Length (cm)</td> <td>20</td> <td>50</td> <td>0</td> <td>0</td> <td>0</td> </tr> <tr> <td>Fullness</td> <td>ON</td> <td>ON</td> <td>ON</td> <td>OFF</td> <td>OFF</td> </tr> <tr> <td>Reduced Speed</td> <td>4000</td> <td>5500</td> <td>5500</td> <td>5500</td> <td>5500</td> </tr> </tbody> </table> <p>( p. 138)</p>		1	2	3	4	5	Length (cm)	20	50	0	0	0	Fullness	ON	ON	ON	OFF	OFF	Reduced Speed	4000	5500	5500	5500	5500						
	1	2	3	4	5																										
Length (cm)	20	50	0	0	0																										
Fullness	ON	ON	ON	OFF	OFF																										
Reduced Speed	4000	5500	5500	5500	5500																										
	 <p>Stepper motor view</p>  <table border="1" data-bbox="1038 1220 1377 1480"> <thead> <tr> <th></th> <th>1</th> <th>2</th> <th>3</th> <th>4</th> <th>5</th> </tr> </thead> <tbody> <tr> <td>Length (cm)</td> <td>20</td> <td>50</td> <td>0</td> <td>0</td> <td>0</td> </tr> <tr> <td>Fullness</td> <td>0</td> <td>0</td> <td>0</td> <td>0</td> <td>0</td> </tr> <tr> <td>Fullness +</td> <td>ON</td> <td>ON</td> <td>OFF</td> <td>OFF</td> <td>OFF</td> </tr> <tr> <td>Reduced Speed</td> <td>4000</td> <td>5500</td> <td>5500</td> <td>5500</td> <td>5500</td> </tr> </tbody> </table> <p>It is possible for each <i>seam section</i> 1-5 to turn the <i>differential top feed increment</i> value ON/OFF separately via <i>Fullness +</i> ( p. 140).</p>   <p>7.3.21 <i>Fullness +</i> Increment for differential bottom feed. Additional fullness for the differential bottom feed, which will be added to the fullness (differential) that has been entered. The quick access icon <i>Fullness +</i> for the differential bottom feed on the main screen offers an easy way to change the differential bottom feed increment value ( p. 140)</p>		1	2	3	4	5	Length (cm)	20	50	0	0	0	Fullness	0	0	0	0	0	Fullness +	ON	ON	OFF	OFF	OFF	Reduced Speed	4000	5500	5500	5500	5500
	1	2	3	4	5																										
Length (cm)	20	50	0	0	0																										
Fullness	0	0	0	0	0																										
Fullness +	ON	ON	OFF	OFF	OFF																										
Reduced Speed	4000	5500	5500	5500	5500																										

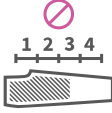
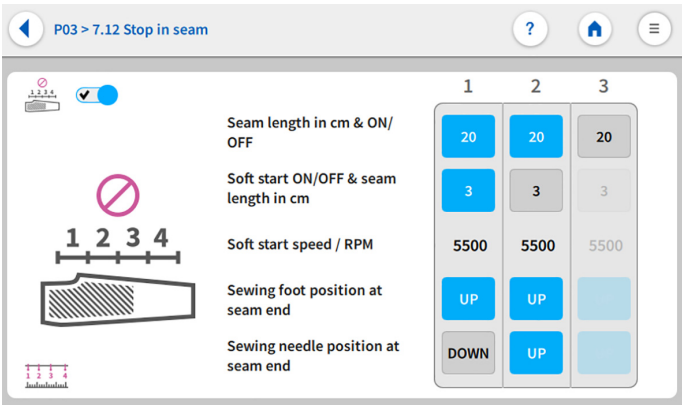





Symbol/parameter	Submenu/setting
 7.4 <i>Table blowing</i> Setting the parameters for the table air nozzles, for lifting and transporting the material towards the stacker during sewing. It reduces the danger of the material getting caught Value range: ON/OFF	 7.4.2 <i>Seam length until table blowing is switched on.</i> Seam length in cm until table blowing is switched on Default: 2 cm Value range: 0-30 cm
	 7.4.3 <i>Seam length with table blowing</i> Seam length in cm with table air nozzles switched on Value range: 1-250 cm
	 7.4.4 <i>Duration of table blowing after seam end</i> Enter the time/duration for table blowing at the end of the seam to ensure that the sewing material is transported towards the stacker and does not get stuck on the table. Default: 100 cm Value range: 0-500 cm
 7.6 <i>Contour guide</i> Setting the parameters for the contour guide. In case of seam thickness, the contour guide can be raised within the seam section to prevent material blockage at the thicker point. Value range: ON/OFF	 7.6.2 <i>Seam length until the contour guide is lowered at the beginning of the seam</i> Seam length in cm until the contour guide is lowered at the beginning of the seam. Default: 1 Value range: 1-10 cm
	 7.6.3 <i>Seam length until contour guide lifts</i> Seam length in cm until the contour guide rises to sew over a seam thickness within the seam. Value range: 0-100 cm
	 7.6.4 <i>Seam length with contour guide up</i> Seam length in cm with raised contour guide for the seam thickening area. Value range: 0-20 cm







Symbol/parameter	Submenu/setting
	  7.6.5 <i>Mode of contour guide</i> 5 modes can be selected for the contour guide
	<p>Other setting options:</p>    7.6.5.1 <i>Mode 1</i> Contour guide is in front of the sewing head in rear position and is inserted by pressing the pedal when sewing starts.
	  7.6.5.2 <i>Mode 2</i> Contour guide is in front of the sewing head and is inserted.
	   7.6.5.3 <i>Mode 3</i> Contour guide is not directly in front of the sewing head and in rear position, is inserted via the pedal and moves in front of the sewing head during the sewing process.
	   7.6.5.4 <i>Mode 4</i> Contour guide is not directly in front of the sewing head, but is inserted. It moves to the sewing head via the pedal
	7.6.5.5 <i>Mode 5</i> Manual sewing - without automatic sequence
	  cm  7.6.6 <i>Contour guide moves in sewing direction</i> Contour guide moves in sewing direction in front of the sewing head after XY cm. Value range: 0-100 cm





Symbol/parameter	Submenu/setting
	 <p>7.6.7 <i>Length until contour moves in front</i> Length until contour moves in front; for contour guide Mode 1 and 3 Value range: 0-50 cm</p>
 <p>7.7 <i>Down holder/stamp</i> Activate/deactivate the down holder at the end of the seam to hold the sewing material during chain cutting. Value range: ON/OFF</p>	
 <p>7.8 <i>Swing out device</i> Setting the parameters for the swing out device. This device is used to swivel short or long sewing pieces closer to the stacker position to ensure a safe stacking process. Value range: ON/OFF</p>	 <p>7.8.2 <i>Seam length in cm until the stacking device swings out</i> Default: 15 cm Value range: 1-30cm</p>
	 <p>7.8.3 <i>Time in seconds until the swing out device swings back to its base position.</i> Default: 0.20 Sec. Value range: 0.00-2.00 Sec.</p>
	 <p>7.8.4 <i>Swing out device position next to the sewing head</i> Here you select the position of the swing out device. ON means that the swing out device is placed next to the sewing head before the sewing start. OFF means that the swing out device is positioned to the left of the stacker before the sewing start. Value range: ON/OFF</p>



Symbol/parameter	Submenu/setting	
 <p>7.10 <i>Stacker</i> Setting the parameters for the stacking process Value range: ON/OFF</p>	 <p>7.10.2 <i>Stacker delay after chain cut</i> Delay time of the stacker in seconds after chain cutting, for safe clamping of the material. Value range: 0.00-3.00 Sec.</p>	
	<p>7.10.3 <i>Stacker position for separating</i> Enter the stacker position on the right or left for separating the parts.</p>	<p>Left L-R Right L-R</p>
 <p>7.12 <i>Stop in seam</i> Setting of up to 3 sewing stops within one seam. This can be used, for example, for attaching labels to the seam. For this purpose, the machine stops at the desired seam point and the label or similar can be added manually. The automatic sewing process can then be restarted (p. 148).</p>	<p>Stop in seam view</p>  <p>The screenshot shows the 'Stop in seam' menu with the following settings:</p> <ul style="list-style-type: none"> Seam length in cm & ON/OFF: 20 (all three columns) Soft start ON/OFF & seam length in cm: 3 (all three columns) Soft start speed / RPM: 5500 (all three columns) Sewing foot position at seam end: UP (all three columns) Sewing needle position at seam end: DOWN (column 1), UP (column 2), (empty) (column 3) 	

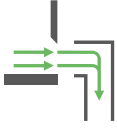

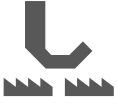
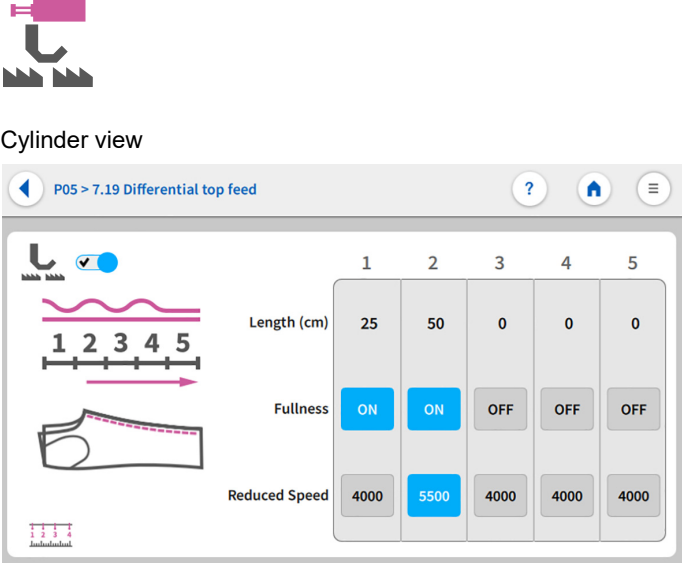
Symbol/parameter	Submenu/setting
 <p>7.13 Puller/Roll-out device Setting the parameters for the puller and the roll-out device.</p>	 <p>7.13.1 Puller The puller transports the material laterally along the sewing head towards the stacker. It ensures that there is no material jam at the height and in front of the sewing head. Value range: ON/OFF</p> <p>Other setting options:</p>  <p>7.13.1.1 Puller Speed Puller speed is set in %. The speed is in relation to the sewing speed. Value range: 70-130%</p>  <p>7.13.1.2 Seam length until puller is lowering Seam length in cm until the puller lowers. Value range: 10 - 250 cm</p>  <p>7.13.1.3 Seam length with puller down Seam length in cm with puller lowered. Value range: 10 - 250 cm</p>  <p>7.13.1.4 Seam length until the puller briefly lifts in between Seam length in cm until the puller briefly lifts. Serves, for instance, to dissolve any jammed material. Value range: 10 - 250 cm</p>  <p>7.13.1.5 Seam length with lifted puller Seam length in cm with lifted puller. Serves, for instance, to dissolve any jammed material. Value range: 0-30 cm</p>

Symbol/parameter	Submenu/setting
	<div style="text-align: center;">  </div> <p>7.13.2 <i>Roll-out device</i> The roll-out device is used to safely position the sewing material for chain cutting and for subsequently rolling it out into the stacker. This ensures for short pieces that the stacker will be able to clamp the material thanks to the extended roll-out position. Value range: ON/OFF</p> <p>Other setting options:</p> <div style="text-align: center;">  </div> <p>7.13.2.1 <i>Seam length until roll-out device is lowering</i> Seam length in cm until roll-out device is lowering. Value range: 0-250 cm</p> <div style="text-align: center;">  </div> <p>7.13.2.2 <i>Seam length with roll-out device down</i> Seam length in cm with roll-out device down. Value range: 0-250 cm</p> <div style="text-align: center;">  </div> <p>7.13.2.3 <i>Seam length until the roll-out device stops</i> Seam length in cm until the roll-out device stops for chain cut. Value range: 1.0 - 20.0 cm</p> <div style="text-align: center;">  </div> <p>7.13.2.4 <i>Speed of roll-out device during sewing</i> Speed of the roll-out device is set in %. The speed is in relation to the sewing speed. Value range: 0-100 %</p> <div style="text-align: center;">  </div> <p>7.13.2.5 <i>Distance until roll-out device stops</i> Distance in cm until the roll-out device stops for the stacking process. Value range: 0-1000 cm</p>

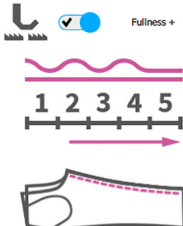
Symbol/parameter	Submenu/setting
	 <p>7.13.2.6 <i>Reduced speed of roll-out device</i> Reduced speed of roll-out device in rpm during chain cut. Value range: 0-100 %</p>  <p>7.13.2.7 <i>Distance with lowered roll-out device while chain cut</i> Distance in cm with lowered roll-out device while chain cut. Value range: 1.0 - 20.0 cm</p>  <p>7.13.2.4 <i>Speed of roll-out device after chain cut</i> Speed of roll-out device in rpm after chain cut. Value range: 30-100 %</p>
 <p>7.14 <i>Correction of chain length at seam end</i> Correction of chain length at seam end in cm. This serves to improve the quality of the seam and increase productivity, as no manual trimming of the chain is necessary. Unnecessarily long chain overhang is corrected here. Default: 1cm Value range: 0.0-10.0 cm</p>	
 <p>7.16 <i>Pneumatic edge guide, for manual fabric cutting</i> The edge guide for manual guiding and trimming of the material edge is used for serging front trousers side seams. The pocket openings are already prefabricated. Only the pocket bag overhang is trimmed. Value range: ON/OFF</p>	 <p>7.16.2 <i>Seam length until edge guide rises after...</i> Input of the seam length without edge guide for trimming the material edge. This should correspond approximately to the length of the pocket bag Default: 25 cm Value range: 1-1000 cm</p>

Symbol/parameter	Submenu/setting																								
 <p>7.18 <i>Waste suction</i> Remove cutting waste by suction Value range: ON/OFF</p>	 <p>7.18.2 <i>Seam length until waste suction starts</i> Seam length in cm until waste suction starts Default: 1 cm Value range: 0-200cm</p>																								
 <p>7.19 <i>Differential top feed</i> The entire seam can be divided in up to 5 seam sections. Parameters can be set independently for each section. Value range: ON/OFF</p>	 <p>Cylinder view</p> <p>P05 > 7.19 Differential top feed</p> <table border="1"> <thead> <tr> <th></th> <th>1</th> <th>2</th> <th>3</th> <th>4</th> <th>5</th> </tr> </thead> <tbody> <tr> <td>Length (cm)</td> <td>25</td> <td>50</td> <td>0</td> <td>0</td> <td>0</td> </tr> <tr> <td>Fullness</td> <td>ON</td> <td>ON</td> <td>OFF</td> <td>OFF</td> <td>OFF</td> </tr> <tr> <td>Reduced Speed</td> <td>4000</td> <td>5500</td> <td>4000</td> <td>4000</td> <td>4000</td> </tr> </tbody> </table> <p>( p. 143)</p>		1	2	3	4	5	Length (cm)	25	50	0	0	0	Fullness	ON	ON	OFF	OFF	OFF	Reduced Speed	4000	5500	4000	4000	4000
	1	2	3	4	5																				
Length (cm)	25	50	0	0	0																				
Fullness	ON	ON	OFF	OFF	OFF																				
Reduced Speed	4000	5500	4000	4000	4000																				

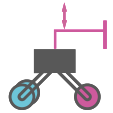
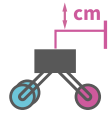
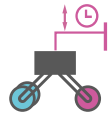
Symbol/parameter	Submenu/setting																														
	<div data-bbox="703 309 799 398" style="text-align: center;">  </div> <p data-bbox="703 434 914 463">Stepper motor view</p> <div data-bbox="703 472 1390 869" style="border: 1px solid gray; padding: 5px;"> <div style="display: flex; justify-content: space-between; align-items: center;"> ← P05 > 7.19 Differential top feed ? 🏠 ☰ </div> <div style="display: flex; align-items: flex-start; margin-top: 10px;"> <div style="flex: 1;">  </div> <div style="flex: 2;"> <table border="1" style="width: 100%; border-collapse: collapse; text-align: center;"> <thead> <tr> <th></th> <th>1</th> <th>2</th> <th>3</th> <th>4</th> <th>5</th> </tr> </thead> <tbody> <tr> <td>Length (cm)</td> <td>25</td> <td>50</td> <td>0</td> <td>0</td> <td>0</td> </tr> <tr> <td>Fullness</td> <td>50</td> <td>0</td> <td>0</td> <td>0</td> <td>0</td> </tr> <tr> <td>Fullness +</td> <td>ON</td> <td>OFF</td> <td>OFF</td> <td>OFF</td> <td>OFF</td> </tr> <tr> <td>Reduced Speed</td> <td>4000</td> <td>5500</td> <td>4000</td> <td>4000</td> <td>4000</td> </tr> </tbody> </table> </div> </div> </div> <p data-bbox="703 882 1398 969">It is possible for each <i>seam section</i> 1-5 to turn the <i>differential top feed increment value</i> ON/OFF separately via <i>Fullness +</i> (📖 p. 145).</p> <div data-bbox="703 1003 821 1120" style="text-align: center;">  </div> <p data-bbox="703 1128 952 1155">7.3.21 <i>Fullness +</i></p> <p data-bbox="703 1158 1066 1184">Increment for differential top feed.</p> <p data-bbox="703 1187 1398 1243">Additional fullness for the differential top feed, which is added to the fullness entered (differential).</p> <p data-bbox="703 1245 1398 1332">The quick access icon <i>Fullness +</i> for the differential top feed on the main screen offers an easy way to change the differential top feed increment value (📖 p. 145).</p>		1	2	3	4	5	Length (cm)	25	50	0	0	0	Fullness	50	0	0	0	0	Fullness +	ON	OFF	OFF	OFF	OFF	Reduced Speed	4000	5500	4000	4000	4000
	1	2	3	4	5																										
Length (cm)	25	50	0	0	0																										
Fullness	50	0	0	0	0																										
Fullness +	ON	OFF	OFF	OFF	OFF																										
Reduced Speed	4000	5500	4000	4000	4000																										

Symbol/parameter	Submenu/setting
 <p>7.21 <i>Transport station</i> Attached to the transport station are the puller at the front and the roll-out device at the rear. Transport station ON = lowering Transport station OFF = lifting If you want the transport station to lower only after cm, you must first set the transport station to ON. After that, you must enter the seam length in the parameter 7.12.1 after which the transport station is to supposed to move up. Value range: ON/OFF</p>	 <p>7.21.1 <i>Seam length in cm until the transport station is to be lowered</i> Default: 0 cm Value range: 0-40cm</p> <hr/>  <p>7.21.2 <i>Delay until transport station moves up</i> Default: 0 Sec. Value range: 0-3.00 Sec.</p>
 <p>7.22 <i>Laser marking lamp</i> The laser marking lamp indicates the position of the seam. Value range: ON/OFF</p>	

5.14.9 Programming the pneumatic differential bottom feed

Parameters for adjusting the 7.3 *Differential bottom feed*.

Fig. 101: Programming the pneumatic differential bottom feed

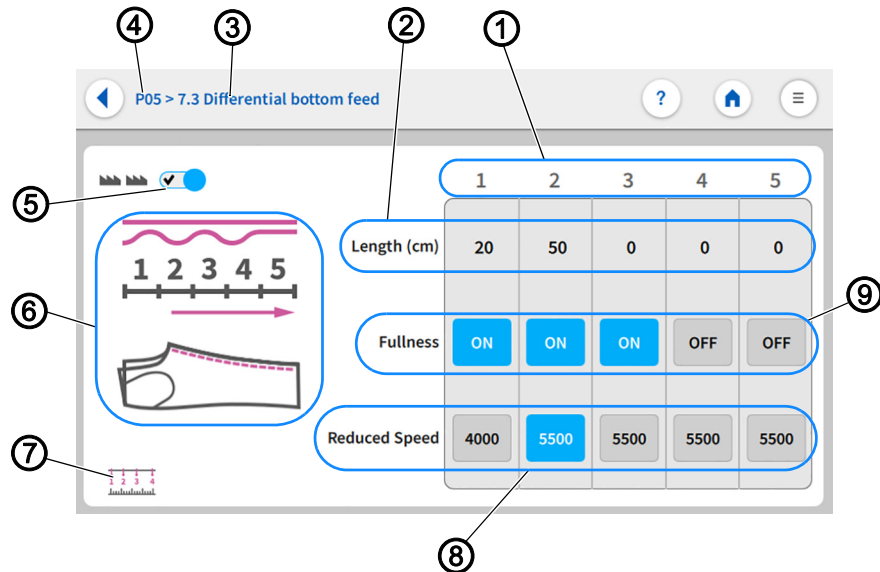

- | | |
|---------------------------------------|-------------------------------------|
| (1) - Seam sections 1-5 | (6) - Graphic Fullness Distribution |
| (2) - Seam Length | (7) - Reference Dimension |
| (3) - Parameter display | (8) - Reduced Speed ON/OFF |
| (4) - Program number | (9) - Fullness |
| (5) - Differential bottom feed ON/OFF | |

The entire seam can be divided in up to 5 seam sections 1-5 (1). Parameters can be set independently for each section.

- The *Seam Length* (2) is set in the measuring unit: cm and can only be adjusted within the range of values
- The *Fullness* (9) can be switched ON/OFF.
- The *Reduced Speed* (8) can be switched ON/OFF.
- The *Reduced Speed* (8) is set in the measuring unit: RPM and can only be adjusted within the range of values.



To enter the seam length:

1. Set *7.3 Differential bottom feed* to ON (5).
- ↳ Only if the *7.3 Differential bottom feed* is switched on can the settings on the user interface *7.3 Differential bottom feed* be adjusted.
2. In *seam section 1* (1), briefly press the numerical value for the *Seam Length* (2).
- ↳ The integrated keyboard opens.
3. Enter the desired *Seam Length* (2) in the active field.

4. Press *Ok*.
 - ↵ The numerical value is stored, and the display returns to the previous user interface.
5. In seam section 1 (1), set the *Fullness* (9) to ON/OFF.
 - ↵ If the appearing field is blue, the function is enabled.
 - ↵ If the appearing field is gray, the function is disabled.
6. In seam section 1 (1), briefly press the numerical value for the *Reduced Speed* (8).
 - ↵ If the appearing field is blue, the function is enabled.
 - ↵ If the appearing field is gray, the function is disabled.
7. In seam section 1 (1), press and hold the numerical value for the *Reduced Speed* (8).
 - ↵ The integrated keyboard opens.
8. Enter the desired *Speed* (8) in the active field.
9. Press *Ok*.
 - ↵ The numerical value is stored, and the display returns to the previous user interface.
10. Repeat the steps 1-9 for each seam section 1-5 (1).
 - ↵ The parameters can be adjusted separately for each *seam section* 1-5 (1).
11. Press on the symbol .
 - ↵ This opens the program parameters page.

5.14.10 Programming the differential bottom feed controlled by the stepper motor

Parameters for adjusting the 7.3 *Differential bottom feed*.

Fig. 102: Programming the differential bottom feed controlled by the stepper motor

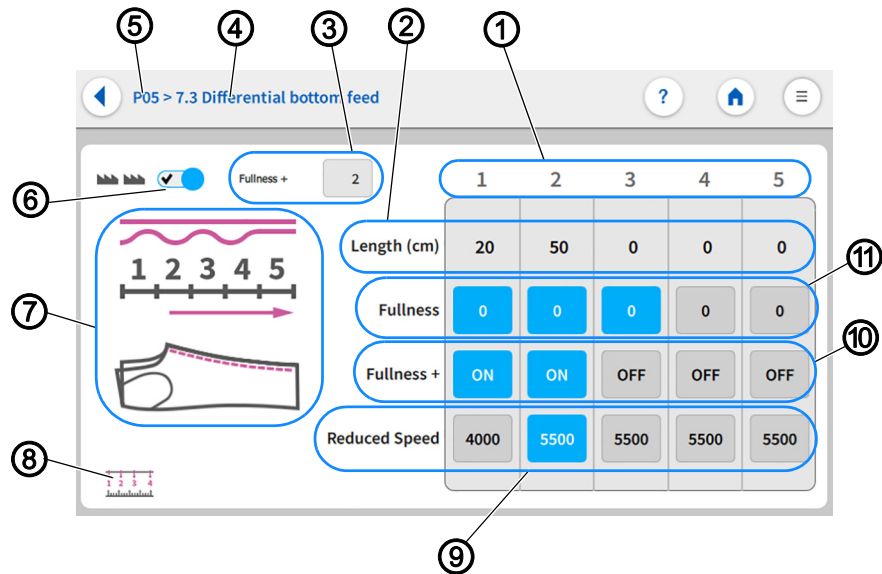

- | | |
|--|-------------------------------------|
| (1) - Seam sections 1-5 | (7) - Graphic Fullness Distribution |
| (2) - Seam Length | (8) - Reference Dimension |
| (3) - Differential bottom feed increment value | (9) - Reduced Speed ON/OFF |
| (4) - Parameter display | (10) - Fullness + |
| (5) - Program number | (11) - Fullness |
| (6) - Differential bottom feed ON/OFF | |

The entire seam can be divided in up to 5 seam sections 1- 5 (1).

Parameters can be set independently for each section.

The differential bottom feed increment value (3) is an additional fullness amount that can be added to the regular fullness (11). This additional fullness amount is the same for all seam sections 1-5 (1), but it can be turned ON/OFF separately for each individual seam section 1-5 (1). The quick access icon *Fullness +* for the *differential bottom feed* on the main screen offers an easy way to change the differential bottom feed increment value (3).

- The *Seam Length* (2) is set in the measuring unit: cm and can only be adjusted within the range of values.
- The *Fullness* (11) can be switched ON/OFF.
- The *Fullness* is set per seam section (11) in the measuring unit: cm and can only be adjusted within the range of values.
- The *Fullness +* (10) can be switched ON/OFF.

- The *Fullness + (10)* is added to the differential value.
 - The *differential bottom feed increment value (3)* is an additional amount of fullness that is added to the *Fullness (11)*.
 - The *differential bottom feed increment value (3)* is set in the measuring unit: cm and can only be adjusted within the range of values.
- The *Reduced Speed (9)* can be switched ON/OFF.
- The *Reduced Speed (9)* is set in the measuring unit: RPM and can only be adjusted within the range of values.



To enter the seam length:

1. Set *7.3 Differential bottom feed* to ON (6).
 - ↳ Only if the *7.3 Differential bottom feed* is switched on can the settings on the user interface *7.3 Differential bottom feed* be adjusted.
2. In *seam section 1 (1)*, briefly press the numerical value for the *Seam Length (2)*.
 - ↳ The integrated keyboard opens.
3. Enter the desired *Seam Length (2)* in the active field.
4. Press *Ok*.
 - ↳ The numerical value is stored, and the display returns to the previous user interface.
5. In *seam section 1 (1)*, briefly press the numerical value for the *Fullness (9)*.
 - ↳ If the appearing field is blue, the function is enabled.
 - ↳ If the appearing field is gray, the function is disabled.
6. In *seam section 1 (1)*, press and hold the numerical value for the *Fullness (9)*.
 - ↳ The integrated keyboard opens.
7. Enter the desired *Fullness (9)* in the active field.
8. Press *Ok*.
 - ↳ The numerical value is stored, and the display returns to the previous interface.
9. In *seam section 1 (1)*, set the *Fullness + (10)* to ON/OFF.
 - ↳ If the appearing field is blue, the function is enabled.
 - ↳ If the appearing field is gray, the function is disabled.
10. In *seam section 1 (1)*, briefly press the numerical value for the *Reduced Speed (8)*.
 - ↳ If the appearing field is blue, the function is enabled.
 - ↳ If the appearing field is gray, the function is disabled.

11. In seam section 1 (1), press and hold the numerical value for the *Reduced Speed* (8).
 - ↳ The integrated keyboard opens.
12. Enter the desired *Speed* (9) in the active field.
13. Press *Ok*.
 - ↳ The numerical value is stored, and the display returns to the previous user interface.
14. Briefly press the *differential bottom feed increment value* (3).
 - ↳ The integrated keyboard opens.
15. Enter the desired *differential bottom feed increment value* (3) in the active field.
16. Press *Ok*.
 - ↳ The numerical value is stored, and the display returns to the previous user interface.
17. Repeat the steps 1-16 for each *seam section 1-5* (1).
 - ↳ The parameters can be adjusted separately for each *seam section 1-5* (1).
 - ↳ It is possible for each *seam section 1-5* (1) to turn the *differential bottom feed increment value* (3) ON/OFF separately via *Fullness +* (11).
18. Press on the symbol .
 - ↳ This opens the program parameters page.

5.14.11 Programming the pneumatic differential top feed

Parameters for adjusting the 7:19 *Differential top feed*.

Fig. 103: Programming the pneumatic differential top feed

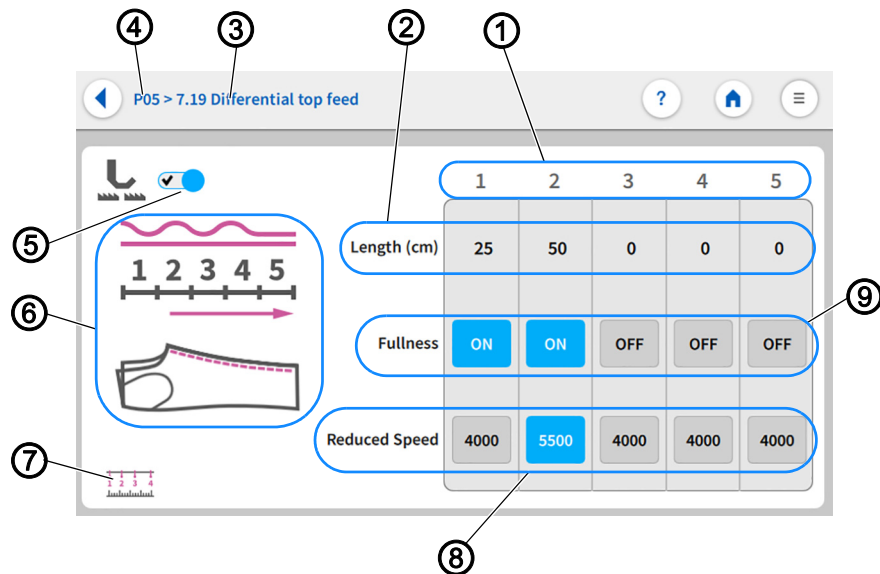

- | | |
|------------------------------------|-------------------------------------|
| (1) - Seam sections 1-5 | (6) - Graphic Fullness Distribution |
| (2) - Seam Length | (7) - Reference Dimension |
| (3) - Parameter display | (8) - Reduced Speed ON/OFF |
| (4) - Program number | (9) - Fullness |
| (5) - Differential top feed ON/OFF | |

The entire seam can be divided in up to 5 seam sections 1-5 (1). Parameters can be set independently for each section.

- The *Seam Length* (2) is set in the measuring unit: cm and can only be adjusted within the range of values.
- The *Fullness* (9) can be switched ON/OFF.
- The *Reduced Speed* (8) can be switched ON/OFF.
- The *Reduced Speed* (8) is set in the measuring unit: RPM and can only be adjusted within the range of values.



To enter the seam length:

1. Set 7.19 *Differential top feed* to ON (5).
- ↳ Only if the 7.19 *Differential top feed* is switched on can the settings on the user interface 7.19 *Differential top feed* be adjusted.
2. In *seam section 1* (1), briefly press the numerical value for the *Seam Length* (2).
- ↳ The integrated keyboard opens.
3. Enter the desired *Seam Length* (2) in the active field.

4. Press *Ok*.
 - ↵ The numerical value is stored, and the display returns to the previous user interface.
5. In seam section 1 (1), set the *Fullness* (9) to ON/OFF.
 - ↵ If the appearing field is blue, the function is enabled.
 - ↵ If the appearing field is gray, the function is disabled.
6. In seam section 1 (1), briefly press the numerical value for the *Reduced Speed* (8).
 - ↵ If the appearing field is blue, the function is enabled.
 - ↵ If the appearing field is gray, the function is disabled.
7. In seam section 1 (1), press and hold the numerical value for the *Reduced Speed* (8).
 - ↵ The integrated keyboard opens.
8. Enter the desired *Speed* (8) in the active field.
9. Press *Ok*.
 - ↵ The numerical value is stored, and the display returns to the previous user interface.
10. Repeat the steps 1-9 for each seam section 1-5 (1).
 - ↵ The parameters can be adjusted separately for each *seam section* 1-5 (1).
11. Press on the symbol .
 - ↵ This opens the program parameters page.

5.14.12 Programming the differential top feed controlled by the stepper motor

Parameters for adjusting the 7.19 *Differential top feed*.

Fig. 104: Programming the differential top feed controlled by the stepper motor

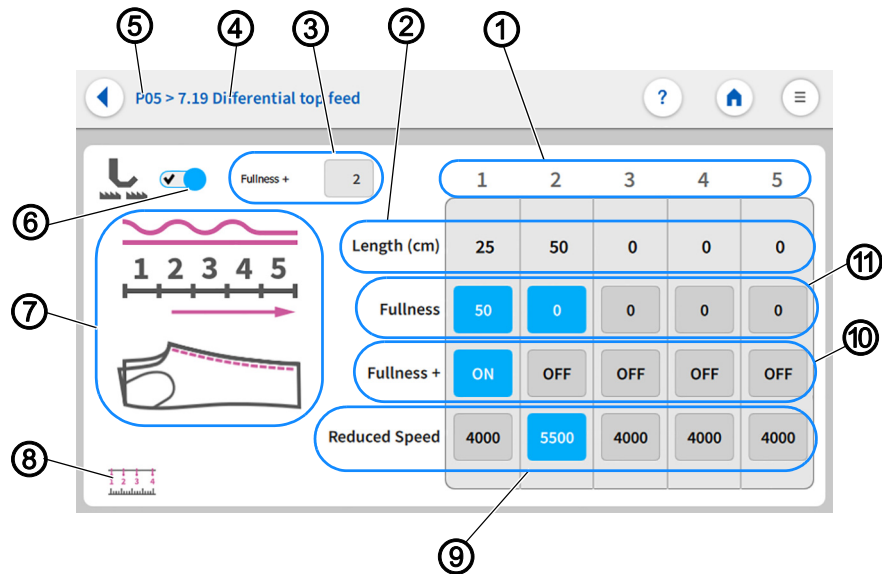

- | | |
|---|-------------------------------------|
| (1) - Seam sections 1-5 | (7) - Graphic Fullness Distribution |
| (2) - Seam Length | (8) - Reference Dimension |
| (3) - Differential top feed increment value | (9) - Reduced Speed ON/OFF |
| (4) - Parameter display | (10) - Fullness + |
| (5) - Program number | (11) - Fullness |
| (6) - Differential bottom feed ON/OFF | |

The entire seam can be divided in up to 5 seam sections 1-5 (1). Parameters can be set independently for each section. The differential top feed increment value (3) is an additional fullness amount that can be added to the regular fullness (11). This additional fullness amount is the same for all seam sections 1-5 (1), but it can be turned ON/OFF separately for each individual seam section 1-5 (1). The quick access icon *Fullness +* for the *differential top feed* offers an easy way to change the differential top feed increment value (3).

- The *Seam Length* (2) is set in the measuring unit: cm and can only be adjusted within the range of values.
- The *Fullness* (11) can be switched ON/OFF.
- The *Fullness* is set per seam section (11) in the measuring unit: cm and can only be adjusted within the range of values.
- The *Fullness +* (10) can be switched ON/OFF.

- The *Fullness + (10)* is added to the differential value.
 - The *differential top feed increment value (3)* is an additional amount of fullness that is added to the *Fullness (11)*.
 - The *differential top feed increment value (3)* is set in the measuring unit: cm and can only be adjusted within the range of values.
- The *Reduced Speed (9)* can be switched ON/OFF.
- The *Reduced Speed (9)* is set in the measuring unit: RPM and can only be adjusted within the range of values.



To enter the seam length:

1. Set *7.19 Differential top feed* to ON (6).
 - ↳ Only if the *7.19 Differential top feed* is switched on can the settings on the user interface *7.19 Differential top feed* be adjusted.
2. In *seam section 1 (1)*, briefly press the numerical value for the *Seam Length (2)*.
 - ↳ The integrated keyboard opens.
3. Enter the desired *Seam Length (2)* in the active field.
4. Press *Ok*.
 - ↳ The numerical value is stored, and the display returns to the previous user interface.
5. In *seam section 1 (1)*, briefly press the numerical value for the *Fullness (9)*.
 - ↳ If the appearing field is blue, the function is enabled.
 - ↳ If the appearing field is gray, the function is disabled.
6. In *seam section 1 (1)*, press and hold the numerical value for the *Fullness (9)*.
 - ↳ The integrated keyboard opens.
7. Enter the desired *Fullness (9)* in the active field.
8. Press *Ok*.
 - ↳ The numerical value is stored, and the display returns to the previous user interface.
9. In *seam section 1 (1)*, set the *Fullness + (10)* to ON/OFF.
 - ↳ If the appearing field is blue, the function is enabled.
 - ↳ If the appearing field is gray, the function is disabled.
10. In *seam section 1 (1)*, briefly press the numerical value for the *Reduced Speed (8)*.
 - ↳ If the appearing field is blue, the function is enabled.
 - ↳ If the appearing field is gray, the function is disabled.

11. In seam section 1 (1), press and hold the numerical value for the *Reduced Speed* (8).
 - ↳ The integrated keyboard opens.
12. Enter the desired *Speed* (9) in the active field.
13. Press *Ok*.
 - ↳ The numerical value is stored, and the display returns to the previous user interface.
14. Briefly press the *differential top feed increment value* (3).
 - ↳ The integrated keyboard opens.
15. Enter the desired *differential top feed increment value* (3) in the active field.
16. Press *Ok*.
 - ↳ The numerical value is stored, and the display returns to the previous user interface.
17. Repeat the steps 1-16 for each *seam section 1-5* (1).
 - ↳ The parameters can be adjusted separately for each *seam section 1-5* (1).
 - ↳ It is possible for each *seam section 1-5* (1) to turn the *differential top feed increment value* (3) ON/OFF separately via *Fullness +* (11).
18. Press on the symbol .
- ↳ This opens the program parameters page.

5.14.13 Setting options for stop in seam

7.12 *Stop in seam* is used, for example, for attaching labels to the seam. For this purpose, the machine stops at the desired seam point, and the label or similar can be added manually. The automatic sewing process can then be restarted.

Fig. 105: Setting options for stop in seam

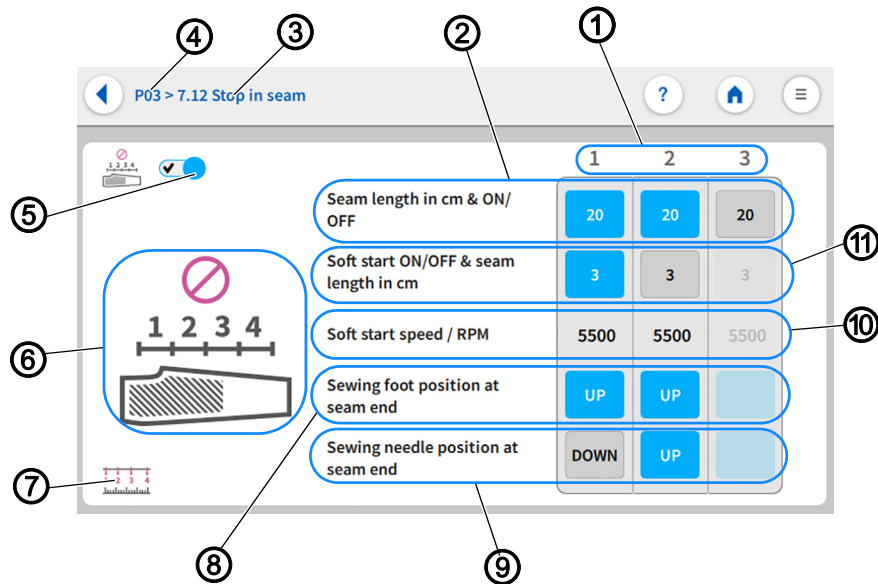

- | | |
|----------------------------------|-------------------------------|
| (1) - Sewing stop 1-3 | (7) - Reference Dimension |
| (2) - Seam Length | (8) - Sewing foot position |
| (3) - Parameter display | (9) - Needle position |
| (4) - Program number | (10) - Soft start speed |
| (5) - Switch stop in seam On/Off | (11) - Soft start seam length |
| (6) - Graphic | |

You can set up to 3 sewing stops (1) along the entire seam. This equals 4 seam sections. The reference dimension (7) serves as a graphical aid, indicating how these seam sections are measured. Reference dimension (7) means that seam sections are always measured from the same measuring point. Setting the sewing foot position (8)/needle position (9) to UP/DOWN at the end of the seam makes it possible to turn the material within the seam without activating thread chain cut. The parameters can be adjusted separately for each seam length (2).

- The *Seam Length* (2) can be switched ON/OFF.
- The *Seam Length* (2) is set in the measuring unit: cm and can only be adjusted within the range of values.
- The *Soft start seam length* (11) can be switched ON/OFF.
- The *Soft start seam length* (11) is set in the measuring unit: cm and can only be adjusted within the range of values.
- The *Soft start speed* (10) is set in the measuring unit: RPM and can only be adjusted within the range of values.

- The *Sewing foot position* (8) can be set to UP/DOWN at the seam end.
- The *Needle position* (9) can be set to UP/DOWN at the seam end.



To enter the seam length:

1. Set *Stop in seam* to ON (5).
 - ↳ Only if *Stop in seam* is switched on can the settings on the user interface *Stop in seam* be adjusted.
2. At sewing stop 1 (1), briefly press the numerical value for the *Seam Length* per seam section (2).
 - ↳ If the appearing field is blue, the function is enabled.
 - ↳ If the appearing field is gray, the function is disabled.
3. Press and hold the active numerical value for the *Seam Length* per seam section (2).
 - ↳ The integrated keyboard opens.
4. Enter the desired *Seam Length* per seam section (2) in the active field.
5. Press *Ok*.
 - ↳ The numerical value is stored, and the display returns to the previous user interface.
6. Briefly press *Soft start seam length* (11).
 - ↳ If the appearing field is blue, the function is enabled.
 - ↳ If the appearing field is gray, the function is disabled.
7. Press and hold the active numerical value for the *Soft start seam length* (11).
 - ↳ The integrated keyboard opens.
8. Enter the desired *Soft start seam length* (11) within the specified value range.
9. Press *Ok*.
 - ↳ The numerical value is stored, and the display returns to the previous user interface.
10. Briefly press *Soft start speed* (10).
 - ↳ The integrated keyboard opens.
11. Enter the desired *Soft start speed* (10) within the specified value range.
12. Press *Ok*.
 - ↳ The numerical value is stored, and the display switches back.
13. Set the *Sewing foot position* (8) at seam end to UP(blue)/DOWN(gray).
14. Set the *Needle position* (9) at seam end to UP(blue)/DOWN(gray).
15. Repeat steps 1-14 for each desired seam section 1-3 (1).
16. Press on the symbol .
 - ↳ This opens the program parameters page.



5.15 Sequence programming

The machine includes 40 sequences which the user can customize with programs.
Each sequence can be filled with a maximum of 14 programs.



Information

Sequences allow the user to sew programs in an automatic sequence.

Sequence programming allows the user to add programs to or remove programs from a particular sequence.

It is not possible to create or delete a sequence.

5.15.1 Sequence programming user interface

Fig. 106: Sequence programming user interface (1)

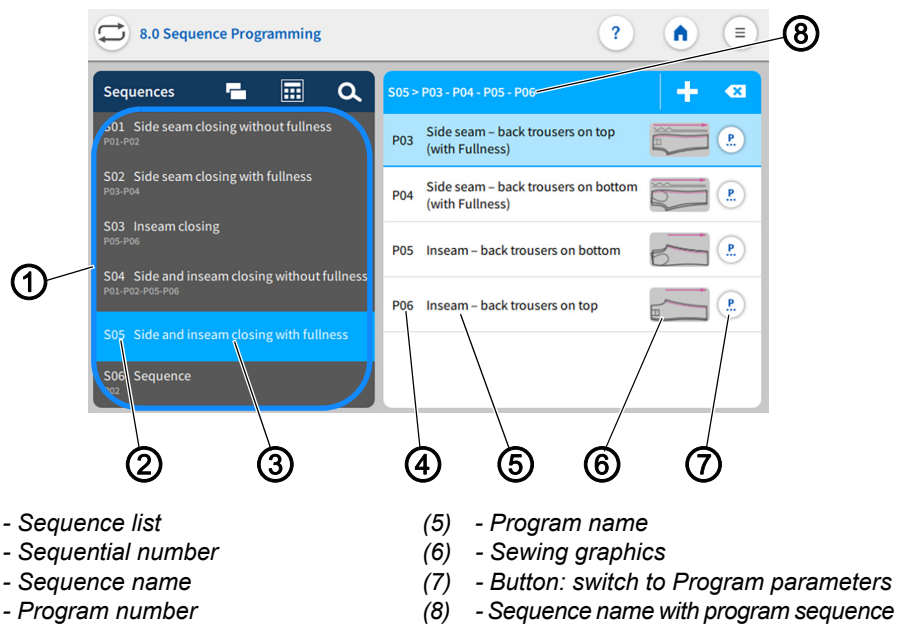
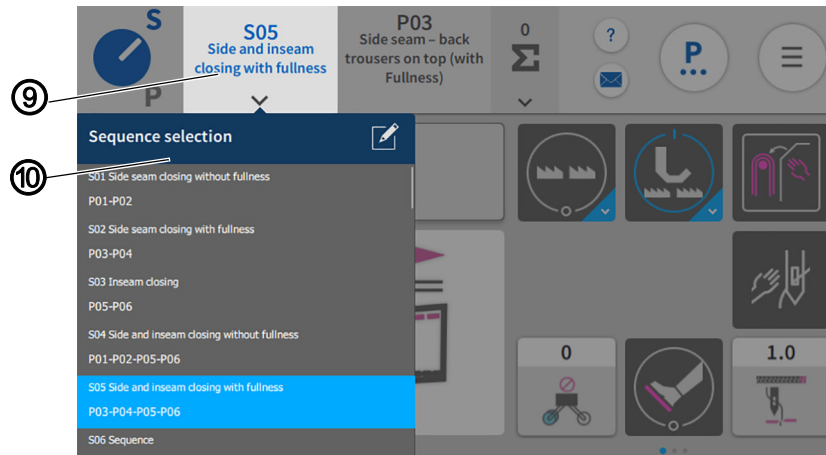

Fig. 107: Sequence programming user interface (2)



(9) - Sequence name

(10) - Sequence selection



To access the function *Sequence Programming*:

- Select the tile (9) Sequence name in the status bar on the main page.

1. Press the tile *Sequence name* (9).

↳ The list holding the *Sequence selection* (10) opens.

2. Press on the symbol .

↳ The user interface *Sequence Programming* opens.

or:

- Via the navigation menu.

1. Press the symbol  to bring up the navigation pane.

↳ This opens the navigation user interface.

Fig. 108: Sequence programming user interface (3)

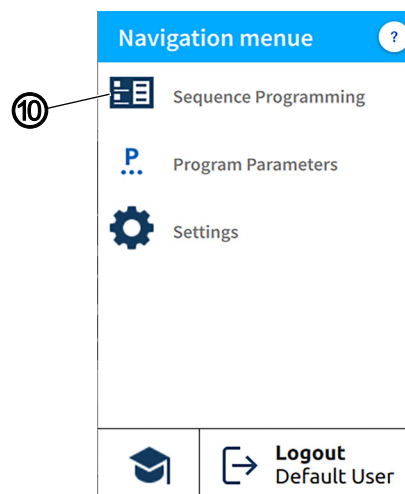

(11) - Sequence Programming



2. Press *Sequence Programming* (10).

↳ The user interface *Sequence Programming* opens.

5.15.2 Programs in the sequence

Overview of the programs contained in the active sequence.

Fig. 109: Programs in the sequence

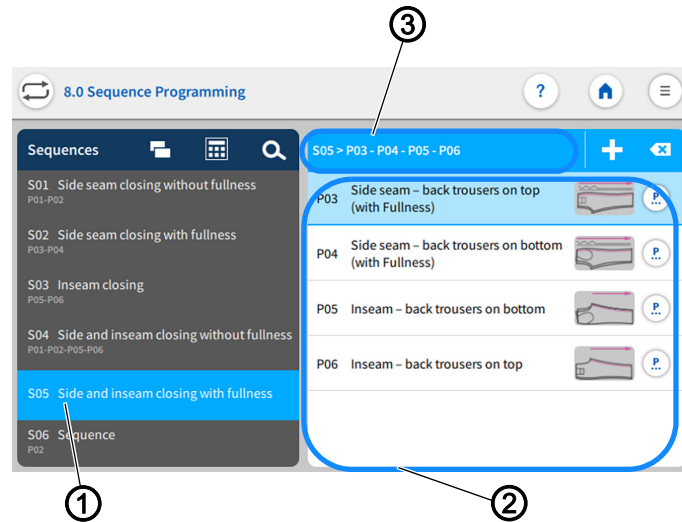

(1) - Sequence
(2) - Programs

(3) - Sequence

The sequence (1) is set to active in the sequence list. Shown on the right is the sequence (3) including the entire program sequence. The corresponding programs (2) are listed underneath.

5.15.3 Adding programs to a sequence



Information

A sequence can never be empty and must always contain at least one program

One sequence can be composed of up to 14 programs.

It is possible to add multiple programs at one time.

It is possible to insert multiple identical program numbers into a sequence.

The grid view contains a color indication for the programs. This color indication can help with the selection of the programs (see table Color indicators in grid view).

Color indicators in grid view

	Used in one/multiple sequences
	User in the current sequence
	Modified, but not used in any sequence.
	Not modified and not used.

Fig. 110: Adding/removing programs (1)

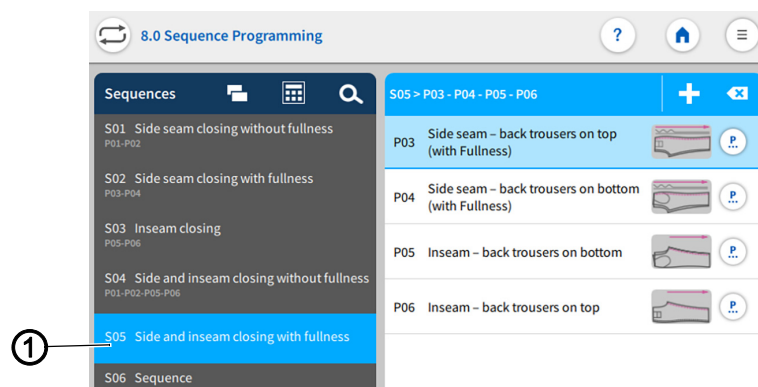

(1) - Sequence



To add programs to a sequence:

1. Select the desired sequence (1) in the sequence list.
 - ↪ The sequence (1) is set to active.
2. Press on the symbol .
 - ↪ A user interface opens showing the program overview with all 200 programs in grid view (3).
 - ↪ In grid view (3), only the program number (4) is visible.

Fig. 111: Adding/removing programs (2)

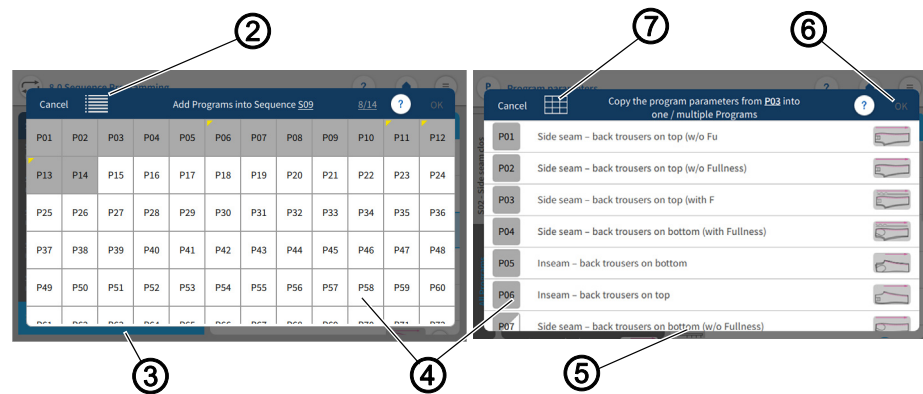

- (2) - Icon
- (3) - Grid view
- (4) - Program number
- (5) - List view
- (6) - OK
- (7) - Icon



3. The symbol (2) allows the user to switch to list view (5).
 - ↳ The list view (5) shows the program number (4), the name and the sewing graphics.
4. The symbol (7) allows the user to return to grid view (3).
5. Select program.
 - ↳ The selected program number is set to active.
6. Press **OK**.
 - ↳ The program is adopted, and the display switches back.

Fig. 112: Adding/removing programs (3)

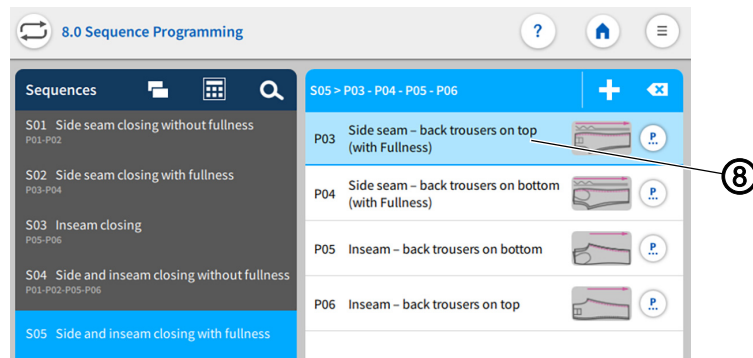

(8) - Program

- ↳ The program (8) you added is now included in the program list.

5.15.4 Removing a program from the sequence



If a user attempts to add more than 14 programs to a sequence, a warning notice ⚠ will be displayed. This notice will prompt the user to remove existing programs in order to add new ones!



To remove a program from a sequence:

1. Select the program (1) you wish to remove in the sequence list.
- ↳ The program (1) is activated.

Fig. 113: Removing a program from the sequence

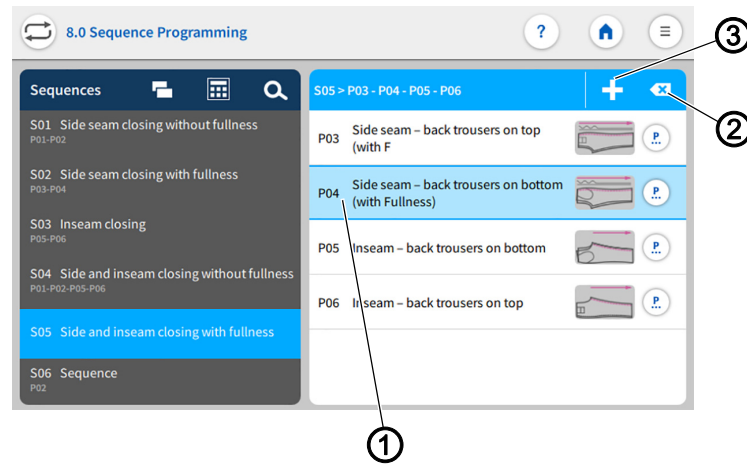

(1) - Program

(2) - Icon

(3) - Icon





2. Briefly press the symbol (2) .

↳ The program (1) is deleted from the current sequence without warning.



To remove all programs from a sequence:

1. Perform a long press on the symbol (2) .

↳ A warning reading  *Confirm "Remove All" appears! A sequence should contain at least one program. Click "Remove All" to remove all programs and add new ones or click "Cancel" to go back.*

2. Press *Cancel/Remove All*.

↳ *Cancel: the user returns to the user interface Sequence Programming.*

↳ *Remove All: Warning notice  Removed last program appears.*

3. Press *Add new program*.

↳ The grid view for programs opens.

4. Select the program you wish to add ( p. 152).

5. Press *OK*.

↳ The program is adopted, and the display switches back.

5.15.5 Program position

The order of the programs in a sequence can be moved quickly up/down.

Fig. 114: Program position

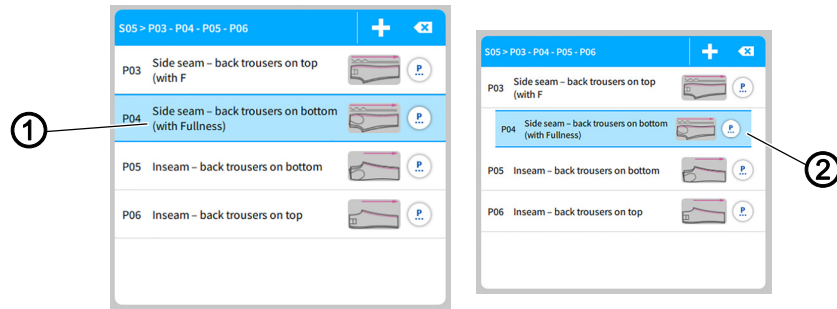

(1) - Program

(2) - Program



To move a program:



1. Select the program (1) you wish to move.
- ↳ The program (1) is activated.
2. Perform a long press on the program (1).
- ↳ The program (2) detaches from the list.
3. Use your finger to drag the program (2) up/down.
4. Release your finger at the desired position.
- ↳ The program (2) settles in at the new position.

5.15.6 Sequence search

When on the *Sequence Programming* user interface, the user can search for specific sequence numbers or sequence names.



To access the function Sequence search.





1. Press the symbol  to bring up the navigation pane.
- ↳ This calls up the user interface with a search field in the sequence list, an overview of the program sequence and an integrated keyboard.
 - You can use the keyboard to enter a sequence number or the sequence name.
 - You can select a sequence directly by scrolling.
 - ↳ The sequence appears and is highlighted in blue.
2. Press *Close*.
3. Exit sequence search with a press of the  symbol.
- ↳ The user interface *Sequence Programming* appears ( p. 150).

5.15.7 Copying sequences

This option lets the user copy the content of a sequence to one or multiple sequences.



To copy sequences.

1. Select the sequence list you wish to copy in the sequence list.
 - ↳ The sequence is highlighted in blue.
2. Press on the symbol .
 - ↳ A window opens showing all sequences including their programs.
3. Activate the desired variant with a press of the  symbol.
4. Confirm with *OK*.
 - ↳ A warning notice reading  *Kindly confirm Copy* appears. *Sequence from (e.g.) S28 will be copied and cannot be recalled!*
5. Press *Cancel/ Copy Sequence*.
 - ↳ *Cancel*: the user returns to the user interface *Sequence Programming*.
 - ↳ *Copy Sequence*: a warning notice appears reading  *Copied-Sequence copied successfully*.
6. Press *OK*.
 - ↳ The program sequence is adopted into the new sequence, and the display returns to the previous user interface.



Important

The copied sequence also contains your quick access configuration!

5.16 Quick access panel

The quick access panel is composed of a grid for 3x3 tiles that is spread over three pages. This provides space for 27 placeholders. The required parameters can be grouped individually and matched with the programs held in a sequence.

To switch from one quick access page to the next, you can swipe to the right or the left on the dots shown below.

5.16.1 Configuration of the quick access icons

This option lets the user configure the quick access icons found on the main screen.



Important

Before they can be used, the parameters for quick access must be switched **ON** in the machine configuration!

It is not necessary to populate every grid.



To access the configuration of the quick access icons:

1. Call up the user interface *Sequence Programming*.
 - Use the status bar on the main page to select the tile Sequence name (📖 p. 150).
 - Via the navigation menu (📖 p. 150).
 2. On the user interface *Sequence Programming*, press on the symbol .
- 👉 The user interface for the configuration of the *Quick Access Icons* opens.

Fig. 115: Configuration of the quick access icons (1)



(1) - Tile shaded red

(2) - Bottom bar

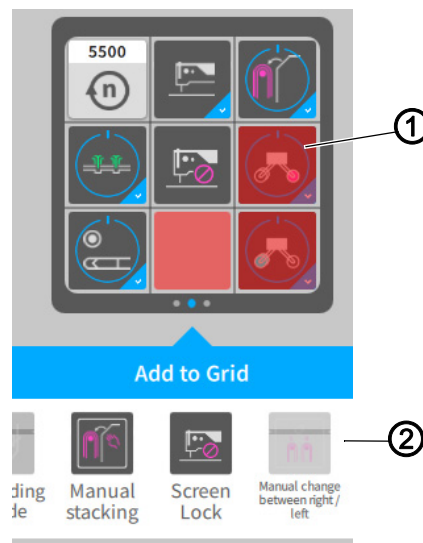

Parameters that have not been selected in the machine configuration or that are inactive will not be shown as a tile on the main screen. The red tile will be shaded red (1) on the user interface *Quick Access Icons*.

If dragged and dropped in the bottom bar (2), the red shaded tile (1) will be **set to invisible** for the user.

Fig. 116: Configuration of the quick access icons (2)

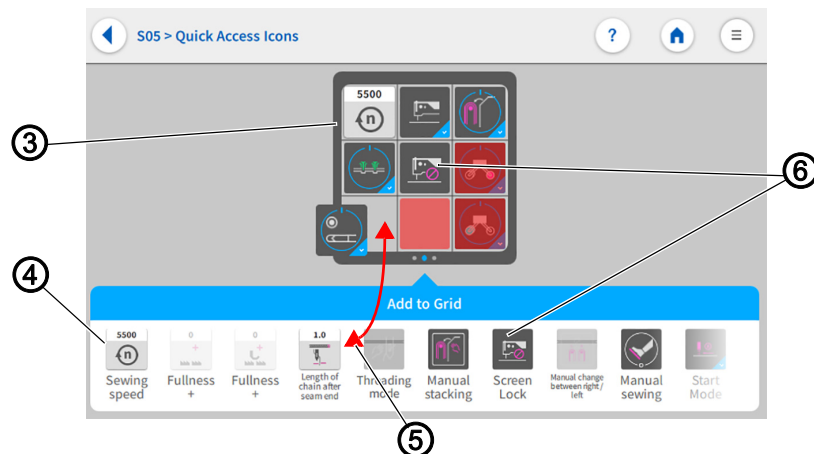

- (3) - Grid of the main screen
 (4) - Bar (of possible tiles)
 (5) - Drag and drop (Drag & Drop function)
 (6) - Tile

All active parameters are contained as tiles (6) in the bottom bar (4).



To configure the tile for quick access:

1. Swipe right/left in the bar (4) to select the desired tile (6).
2. Press and hold the tile (6) in the bar (4).
- ↳ The tile (6) detaches from the bar (4).
3. Use drag & drop (5) to move the tile (6) out of the bar (4) and into the grid (3) at the desired position.
4. Or vice versa: Use drag & drop (5) to move the tile (6) from the grid (3) into the bar (4).
5. Keep repeating the process until all tiles have been moved to the desired position.
6. Press on the symbol .
7. The settings are adopted, and the display returns to *Sequence Programming*.

5.17 Using manual data transfer

Use this submenu to transfer data between the machine – or, more precisely, the control panel – and a USB key. Various options are available for the data transfer.

- Exporting data
- Importing data



Important

Programs cannot be imported or exported by the *Default User*. This process requires that the user be logged in as a *Technician* (📖 p. 111).

A USB key is used to transfer and store the machine software. It is recommended to use a USB key that is compatible and was purchased from Dürkopp Adler.

The USB key makes it possible to transfer program and parameter data to other machines as well.

5.17.1 Exporting data



To export data:

1. Connect the USB key at the control panel.
2. Press the symbol  to bring up the navigation pane.
 - ↳ This opens the navigation user interface.



Important

This process requires that the user be logged in as a *Technician* (📖 p. 111).

Fig. 117: Exporting data (1)

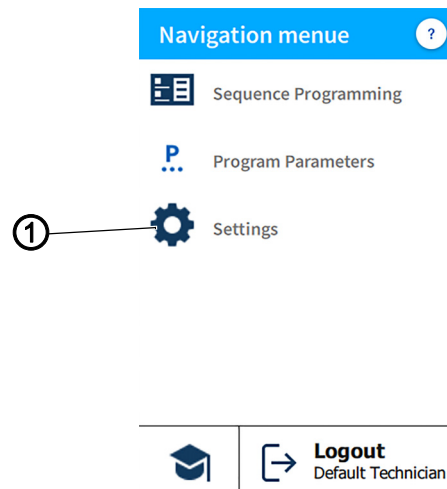

(1) - *Settings*



3. Press *Settings* (1).
 - ↳ This opens the *Settings* user interface.

Fig. 118: Exporting data (2)

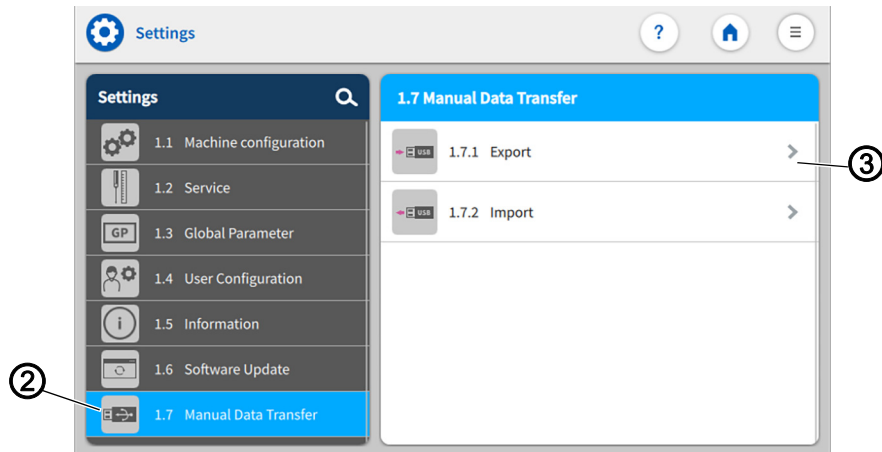

(2) - Symbol Manual Data Transfer (3) - Export



4. Press the symbol  of the *Manual Data Transfer* (2).
 ↳ The user interface for the *Manual Data Transfer* opens on the right.
5. Press *Export* (3).
 ↳ The export list (4) containing the application data (5) opens on the right.

Fig. 119: Exporting data (3)



(4) - Export list (5) - Application data

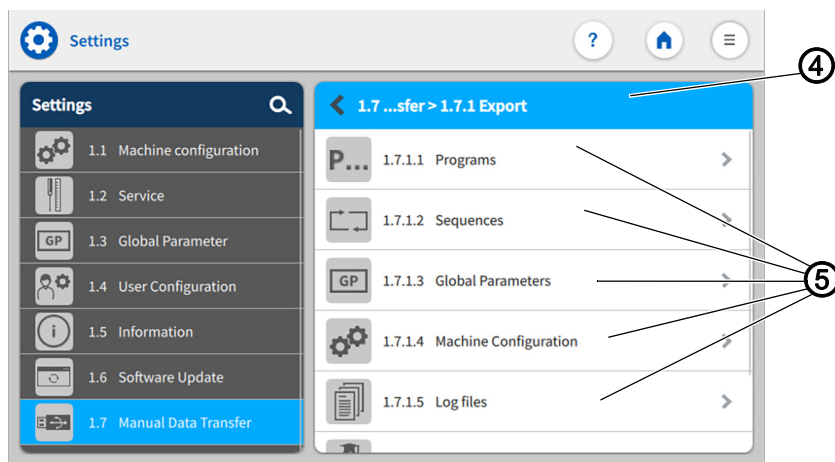

6. Select and press an application file (5).
 ↳ The window *Choose export destination* (6) opens.

Fig. 120: Exporting data (4)

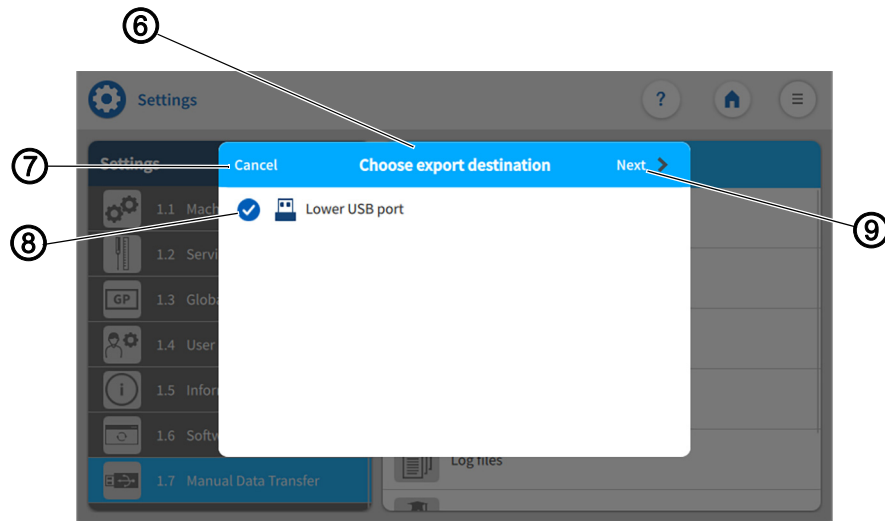

- (6) - Window Choose export destination (8) - Activate
(7) - Cancel (9) - Next



7. Activate the export destination (8).
 8. Press *Cancel* (7).
- ↪ The display returns to the previous user interface.

Fig. 121: Exporting data (5)



- (10) - Application file Program (14) - Next page
(11) - Back (15) - Application file Sequence
(12) - Select All (16) - File
(13) - Activate (17) - Export

9. Press *Next* (9).
 - ↳ The export process continues.
 - ↳ In each selected application file (5):
 - Program (10): select one file/multiple files (16)
 - Sequence (15): select one file/multiple files (16)
 - Global Parameters: press *Export* (17)
 - Machine Configuration: press *Export* (17)
 - Log files: press *Export* (17)
 - Customer Multimedia: press *Export* (17)
 - Vendor Multimedia: select one file/multiple files (16)
10. Select and activate (13) one / multiple files (16).
 - The *Select All* (12) option is used to activate (13) all files (16) contained in the window.
 - You can set individual files (16) to active/inactive.
11. Press *Back* (11).
 - ↳ The display returns to the previous user interface.
12. Press *Export* (17).
 - ↳ A new window (18) opens.

Fig. 122: Exporting data (6)

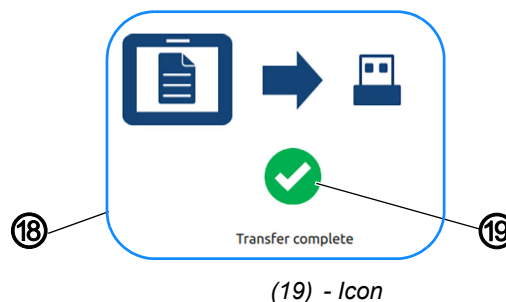

(18) - Window

(19) - Icon

13. When the symbol (19) appears,
 - ↳ the transfer has been completed successfully.
14. Press *OK*.
 - ↳ The display returns to the export list (4).

5.17.2 Importing data

- To import data:
1. Connect the USB key at the control panel.
 2. Press the symbol  to bring up the navigation pane.
 - ↳ This opens the navigation user interface.



Important

This process requires that the user be logged in as a **Technician** ( p. 111).

Fig. 123: Importing data (1)



(1) - Settings

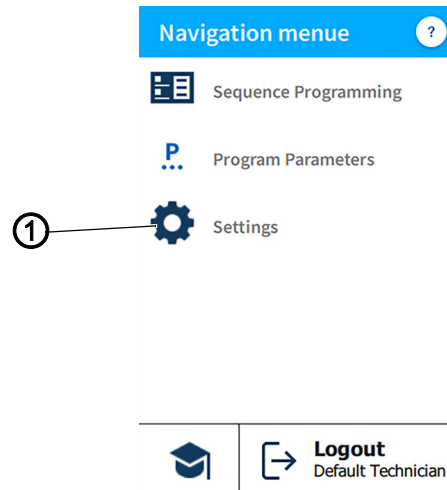

3. Press *Settings* (1).
 This opens the *Settings* user interface.

Fig. 124: Importing data (2)

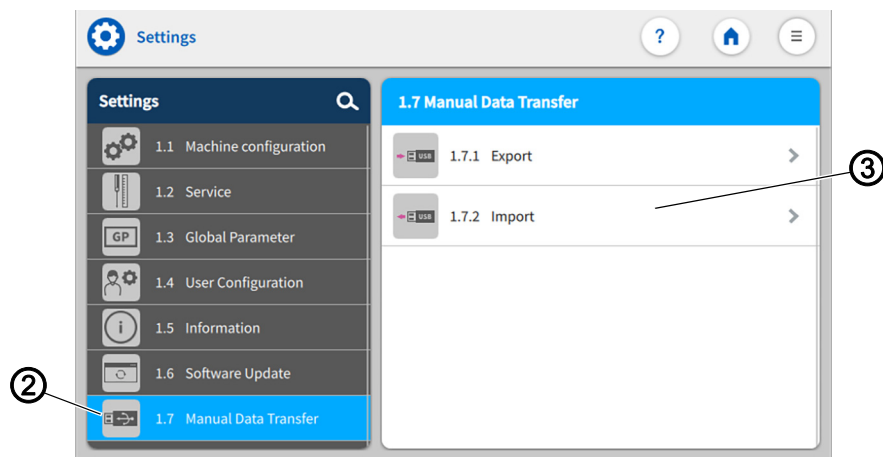

(2) - Symbol *Manual Data Transfer*

(3) - *Import*



4. Press the symbol  of the *Manual Data Transfer* (2).
 The user interface for the *Manual Data Transfer* opens on the right.
5. Press *Import* (3).
 The import list (4) containing the application data (5) opens on the right.

Fig. 125: Importing data (3)



(4) - Import list

(5) - Application data

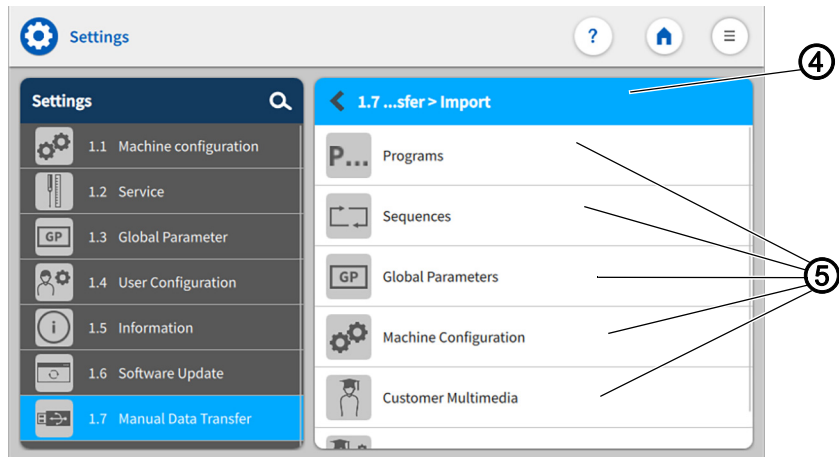

6. Select and press an application file (5).

↳ The window Choose import source (6) opens.

Fig. 126: Importing data (4)

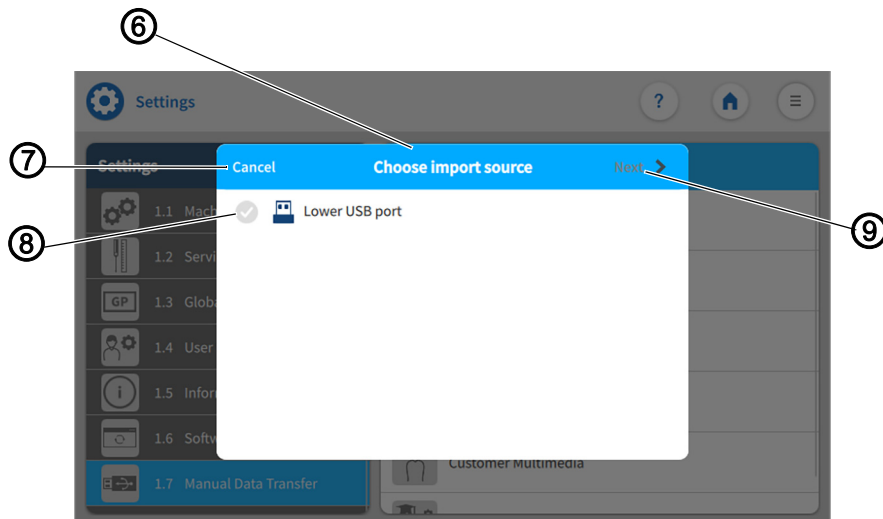

(6) - Window Choose import source

(8) - Activate

(7) - Cancel

(9) - Next



7. Activate the import source (8).

8. Press *Cancel* (7).

↳ The display returns to the previous user interface.

Fig. 127: Importing data (5)



- (10) - Application file Program
- (11) - Back
- (12) - Select All
- (13) - Activate

- (14) - Next page
- (15) - Application file Sequence
- (16) - File
- (17) - Import



9. Press *Next* (9).

↳ The import process continues.

↳ In each selected application file (5):

- Program (10): select one file/multiple files (16)
- Sequence (15): select one file/multiple files (16)
- Global Parameters: press *Import* (17)
- Machine Configuration: press *Import* (17)
- Log files: press *Import* (17)
- Customer Multimedia: select one file/multiple files (16)
- Vendor Multimedia: select one file/multiple files (16)

10. Select and activate (13) one / multiple files (16).

- The *Select All* (12) option is used to activate (13) all files (16) contained in the window.
- You can set individual files (16) to active/inactive.

11. Press *Back* (11).

↳ The display returns to the previous user interface.

12. Press *Import* (17).

↳ A new window (18) opens.

Fig. 128: Importing data (6)

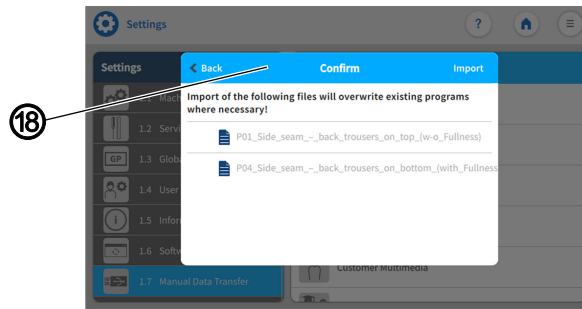

(18) - Window Confirm



The following information is given to the user:

Import of the following files will overwrite existing programs where necessary.

Fig. 129: Importing data (7)

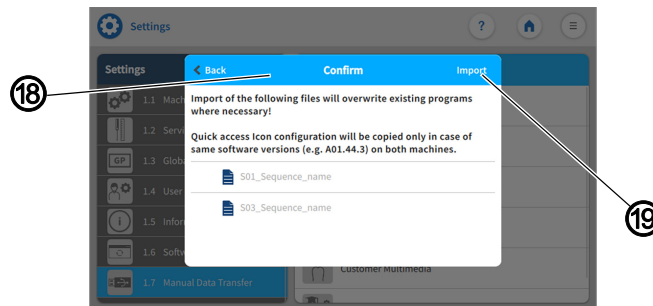

(19) - Import



If in the application file (5) of the sequences (15), the user will be given the following additional information:

Quick access icon configuration will be copied only in case of same software version on both machines.

13. Press *Import* (19).

A new window opens.

Fig. 130: Importing data (8)

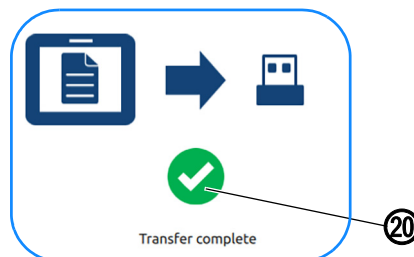

(20) - Icon



14. When the symbol (20) appears,

the transfer has been completed successfully.

15. Press *OK*.

↩ The display returns to the import list (4).



Important

When the import is complete, restart the control panel to check if all imported configurations are compatible.

5.18 Software update for the control panel



Follow the order for control panel and control when performing the software updates:

1. Perform the update for the control panel.
2. Perform the update for the control.

A software update requires a USB key.

When a new software version is available, it can be downloaded at www.duerkopp-adler.com and be uploaded from a USB key. It is recommended to use a USB key that is compatible and was purchased from Dürkopp Adler. All settings on the machine are retained.



Information

To secure your data, we recommend:

- Saving your program data and creating a backup before performing the software update ( p. 160).
- Use a blank USB key to download the new version.



To perform a software update:

1. Download the latest/desired software version from Dürkopp Adler's website.
2. Save the software version to a USB key.
3. Plug the USB key into the port on the control panel.
4. Press the symbol  to bring up the navigation pane.

↩ This opens the navigation user interface.



Important



This process requires that the user be logged in as a *Technician* ( p. 111).

Fig. 131: Performing a software update (1)

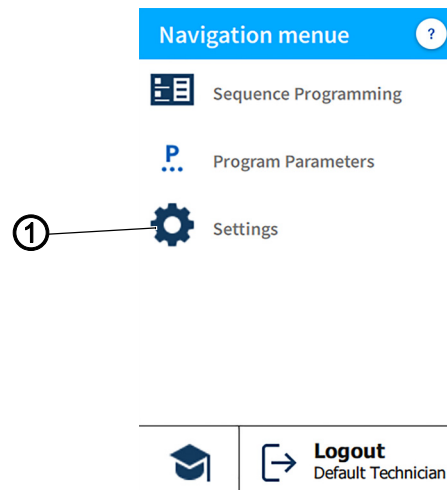

(1) - Settings

5. Press *Settings* (1).
6. This opens the Settings user interface.
7. Open the menu *Settings* (1) and press the *Software Update*  option.

↳ A window listing the files (2) stored on the USB key opens.

Fig. 132: Performing a software update (2)

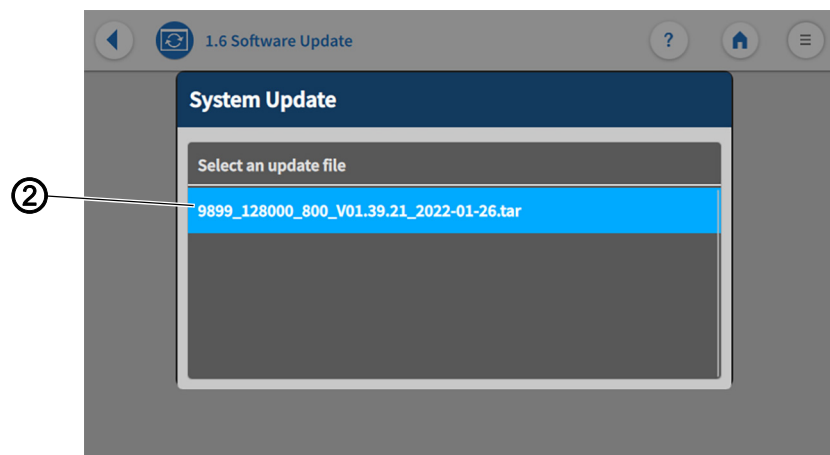

(2) - File

8. Select the file (2) containing the software update.
- ↳ Another window opens.
9. To start the software update, press on the *Start Update* button.
10. Wait until advised that the USB key can be removed/that the control panel was restarted.
11. Once the control panel has been restarted, the machine can be used again.
12. The USB key can now be removed.

5.19 Software update for the control



Follow the order for control panel and control when performing the software updates:

1. Perform the software update for the control panel.
2. Perform the software update for the control.

A software update requires a USB key.

When a new software version is available, it can be downloaded at www.duerkopp-adler.com and be uploaded from a USB key. It is recommended to use a USB key that is compatible and was purchased from Dürkopp Adler. All settings on the machine are retained.





Information

To secure your data, we recommend:

- Saving your program data and creating a backup before performing the software update ( p. 160).
- Use a blank USB key to download the new version.





Proceed in the following order when performing a software update for the control:

1. Check the installed software version ( p. 170).
2. Switch off the control ( p. 171).
3. Download the new/desired software version from Dürkopp Adler's website.
4. Save the new software version to a USB key.
5. Perform the software update ( p. 171).

5.19.1 Checking the installed software version



To check the installed software version:

1. Press the symbol  to bring up the navigation pane.
-  This opens the navigation user interface.



Important

This process requires that the user be logged in as a **Technician** ( p. 111).

Fig. 133: Software update for the control (1)



(1) - Settings

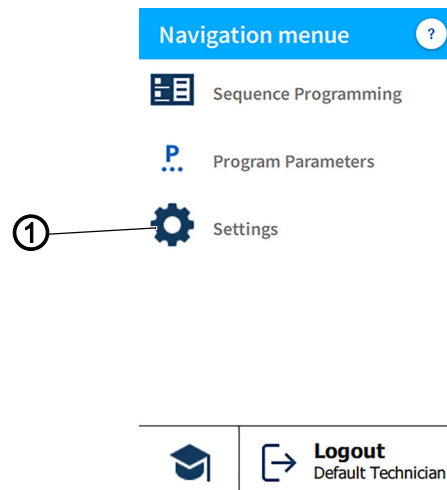

2. Press *Settings* (1).

↳ This opens the Settings user interface.

3. Open the menu *Settings* (1) and press the *Information* (i) option.

↳ Different symbols are shown in the submenu on the right side (📖 p. 86).

4. Press the symbol  *Software Version*.

↳ The software version of the control panel is displayed.

↳ The software version of the machine is displayed.

5.19.2 Performing a software update

Fig. 134: Performing a software update

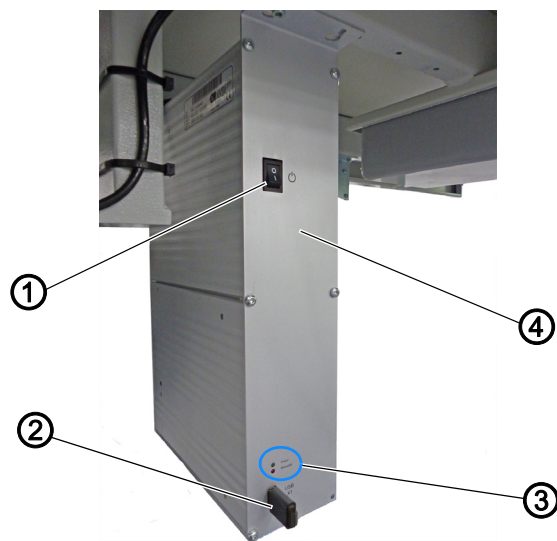

(1) - ON/OFF switch

(2) - USB key

(3) - LED lights

(4) - Control



To perform a software update:

1. Plug the USB key (2) holding the new software version into the control (4).
2. Switch on the control (4) using the ON/OFF switch (1).
 - ↪ The control panel comes on automatically.
 - ↪ Ignore the message displayed on the control panel.
 - ↪ The two LED lights (3) POWER and MESSAGE on the control (4) flash.
 - ↪ When the software update is complete, the two LED lights (3) on the control (4) will stop flashing.
 - The POWER LED illuminates green.
 - The MESSAGE LED is off.

CAUTION



Control malfunction if USB key is removed prematurely!

Loss of data.

Do not remove the USB key until the machine has been switched off.

3. Switch the control (4) off using the ON/OFF switch (1).
4. When the software update is complete, switch off the machine at the main switch ([p. 15](#)) and wait until the LED light strip ([p. 71](#)) on the control panel goes out.
5. Remove the USB key (2) from the control (4).
6. Switch on the machine again at the main switch ([p. 15](#)).
 - ↪ The machine starts up.
 - ↪ The start screen is displayed.
7. Go to the user interface *Settings* ([p. 82](#)) on the control panel and open *Information* ([p. 86](#)) to check the *Software Version*.



Important

Do not perform the software update if the installed software version is newer than the version stored on the USB key.

6 Maintenance

WARNING



Risk of injury from sharp parts!

Punctures and cutting possible.

Prior to any maintenance work, switch off the machine or set the machine to threading mode.

WARNING



Risk of injury from moving parts!

Crushing possible.

Prior to any maintenance work, switch off the machine or set the machine to threading mode.

This chapter describes maintenance work that needs to be carried out on a regular basis to extend the service life of the machine and achieve the desired seam quality.

Advanced maintenance work may only be carried out by qualified specialists.

Maintenance intervals

Work to be carried out	Operating hours			
	8	40	160	500
Machine head				
Remove sewing dust and thread residues	●			
Check oil level		●		
First oil change			●	
Subsequent oil changes	every 2 years			
Control box				
Remove sewing dust and thread residues	●			
Air suction device				
Empty container	●			
Remove any sewing dust and thread residues below the sliding plate		●		
Pneumatic system				
Check the water level in the pressure regulator	●			
Clean the filter element in the compressed air maintenance unit				●
Check the tightness of the system	●			

6.1 Cleaning

WARNING



Risk of injury from flying particles!

Flying particles can enter the eyes, causing injury.

Wear safety goggles.

Hold the compressed air gun so that the particles do not fly close to people.

Make sure no particles fly into the oil pan.

NOTICE

Property damage from soiling!

Sewing dust and thread residues can impair the operation of the machine.

Clean the machine as described.

NOTICE

Property damage from solvent-based cleaners!

Solvent-based cleaners will damage paintwork.

Use only solvent-free substances for cleaning.

Fig. 135: Cleaning

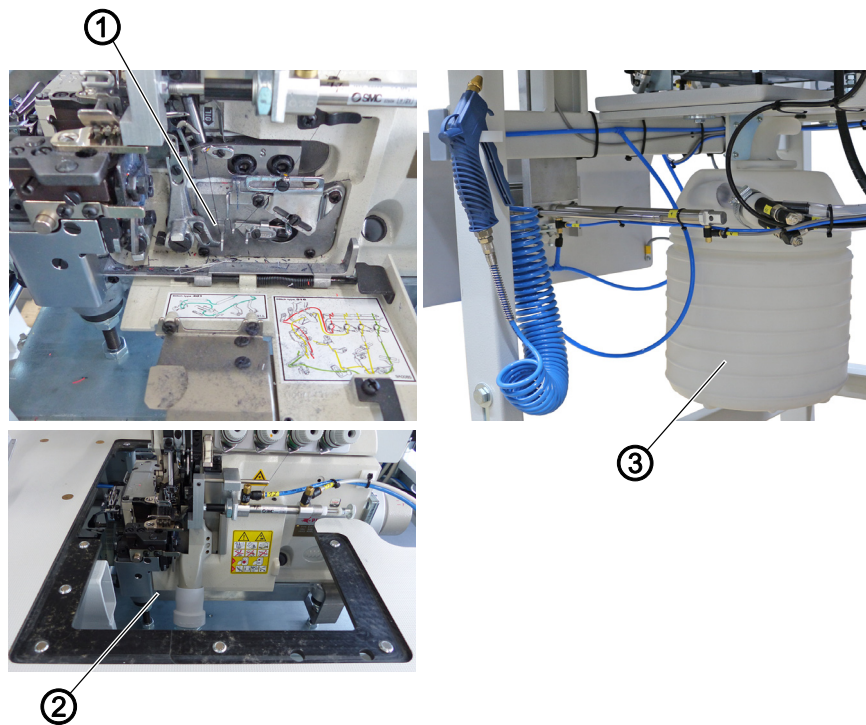

(1) - Thread guides

(2) - Under the fabric sliding plate

(3) - Suction container



To clean the machine:

1. Switch off the machine at the main switch.
2. Use a compressed air gun to blow out the entire area around the thread guides (1).
3. Use a compressed air gun to blow out the entire area under the fabric sliding plate (2).
4. Remove and empty the suction container (3).

6.2 Lubricating

CAUTION



Risk of injury from contact with oil!

Oil can cause a rash if it comes into contact with skin.

Avoid skin contact with oil.
If oil has come into contact with your skin, wash the affected areas thoroughly.

NOTICE

Property damage from incorrect oil!

Incorrect oil types can result in damage to the machine.

Only use oil that complies with the data in the instructions.

CAUTION



Risk of environmental damage from oil!

Oil is a pollutant and must not enter the sewage system or the soil.

Carefully collect up used oil.
Dispose of used oil and oily machine parts in accordance with national regulations.

The machine is equipped with a central lubrication system. The bearings are supplied from the oil reservoir.

Information on refilling and the specification of the oil used is provided in the separately included operating Instructions of the sewing head manufacturer ( *Operating Instructions Machine Head*).

- Mobile Velcote Oil No10

6.2.1 Checking the lubrication of the machine head

Fig. 136: Checking the lubrication of the machine head

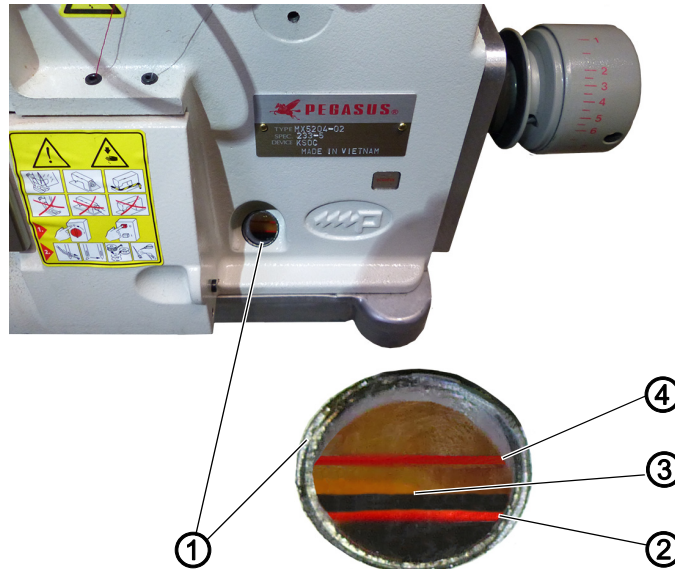

(1) - Inspection glass
(2) - Minimum level marking

(3) - Oil level
(4) - Maximum level marking



Proper setting

The oil level (3) is between the minimum level marking (2) and the maximum level marking (4).

To check the lubrication of the machine head:



1. Check the oil level indicator (3) at the inspection glass (1) every day.
2. Refill oil if the oil level (3) drops to/below the minimum level marking (2) ( *Operating Instructions Machine Head*).

6.3 Servicing the pneumatic system

6.3.1 Adjusting the operating pressure

NOTICE

Property damage from incorrect adjustment!

Incorrect operating pressure can result in damage to the machine.

Ensure that the machine is only used when the operating pressure is set correctly.



Proper setting

Refer to the **Technical Data** ( p. 209) chapter for the permissible operating pressure. The operating pressure cannot deviate by more than ± 0.5 bar.

Check the operating pressure on a daily basis.

Fig. 137: Adjusting the operating pressure

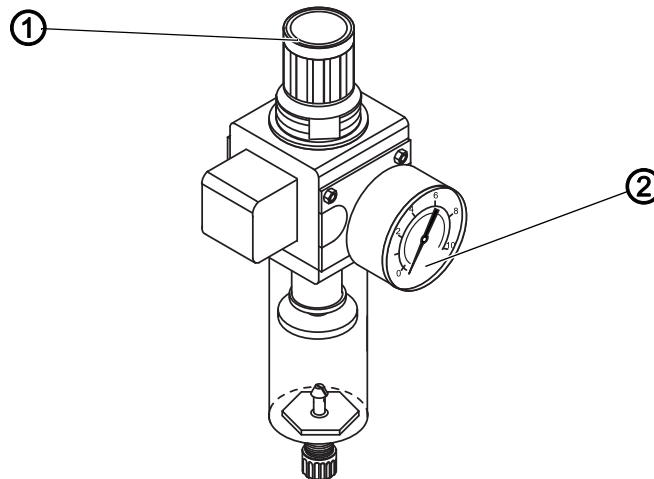

(1) - Pressure regulator

(2) - Pressure gage



To adjust the operating pressure:

1. Pull the pressure regulator (1) up.
2. Turn the pressure regulator until the pressure gage (2) indicates the proper setting:
 - Increase pressure = turn clockwise
 - Reduce pressure = turn counterclockwise
3. Push the pressure regulator (1) down.

6.3.2 Draining the water condensation

NOTICE

Property damage from excess water!

Excess water can cause damage to the machine.

Drain water as required.

Water condensation accumulates in the water separator (2) of the pressure regulator.



Proper setting

Water condensation must not rise up to the level of the filter element (1).

Check the water level in the water separator (2) on a daily basis.

Fig. 138: Draining the water condensation

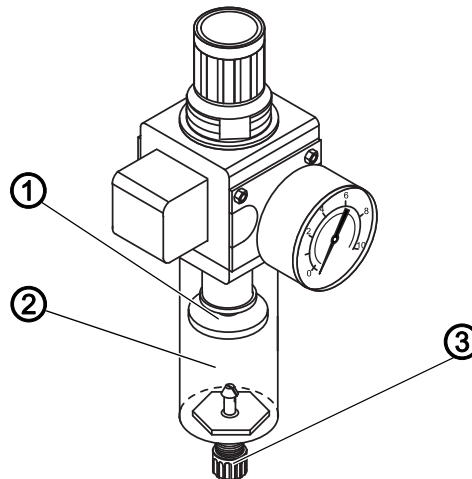

(1) - Filter element
(2) - Water separator

(3) - Drain screw



To drain water condensation:

1. Disconnect the machine from the compressed air supply.
2. Place the collection tray under the drain screw (3).
3. Loosen the drain screw (3) completely.
4. Allow water to drain into the collection tray.
5. Tighten the drain screw (3).
6. Connect the machine to the compressed air supply.

6.3.3 Cleaning the filter element

NOTICE

Damage to the paintwork from solvent-based cleaners!

Solvent-based cleaners damage the filter.

Use only solvent-free substances for washing out the filter tray.

Fig. 139: Cleaning the filter element

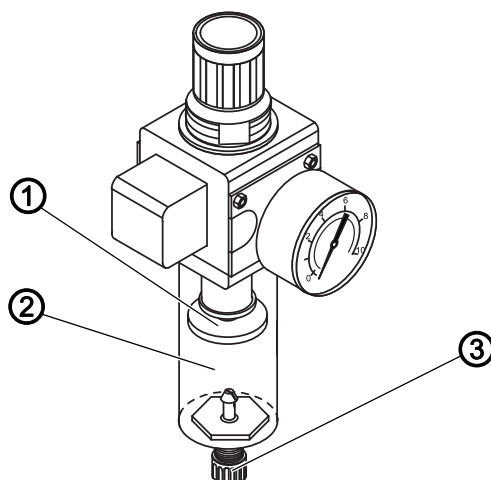

(1) - Filter element
(2) - Water separator

(3) - Drain screw



To clean the filter element:

1. Disconnect the machine from the compressed air supply.
2. Drain the water condensation ( p. 178).
3. Loosen the water separator (2).
4. Unscrew the filter element (1).
5. Blow out the filter element (1) using the compressed air gun.
6. Wash out the filter tray using benzine.
7. Tighten the filter element (1).
8. Tighten the water separator (2).
9. Tighten the drain screw (3).
10. Connect the machine to the compressed air supply.

6.4 Parts list

A parts list can be ordered from Dürkopp Adler. Or visit our website for further information at: www.duerkopp-adler.com



7 Setup

WARNING



Risk of injury from cutting parts!

Cutting injuries may be sustained while unpacking and setting up the machine.

Only qualified specialists may set up the machine.
Wear safety gloves

WARNING



Risk of injury from moving parts!

Crushing injuries may be sustained while unpacking and setting up the machine.

Only qualified specialists may set up the machine.
Wear safety shoes.

7.1 Checking the scope of delivery

The scope of delivery depends on your specific order. Check that the scope of delivery is correct after taking delivery.

7.2 Removing the transport locks

Remove all transport locks before setting up the machine:

- Protective films
- Lashing straps on reel stand, stand, stacker, etc.
- Machine head fasteners

7.3 Adjusting the working height

WARNING



Risk of injury from moving parts!

The tabletop can sink under its own weight when the screws on the stand bars are loosened. Crushing possible.

Ensure that your hands are not jammed when loosening the screws.

CAUTION



Risk of musculoskeletal damage from incorrect setting!

The operator can sustain musculoskeletal damage if failing to comply with the ergonomic requirements.

Adjust the working height to the body height of the person who will operate the machine.

Fig. 140: Adjusting the working height (1)

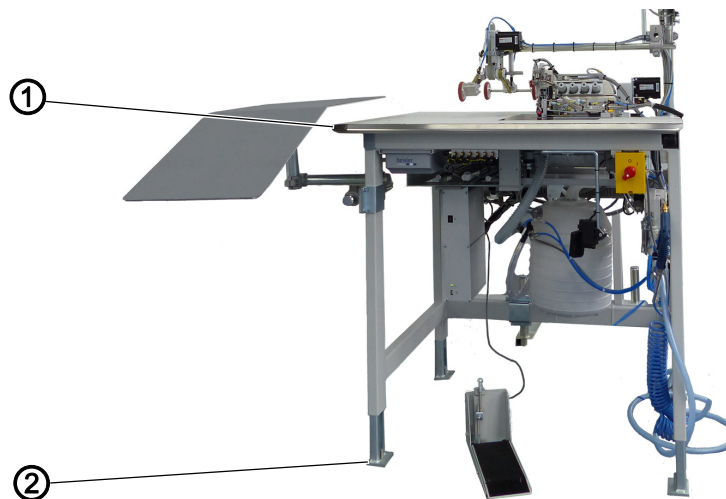

(1) - Upper edge of the tabletop
(Example: 1280)

(2) - Floor

The working height can optionally be adjusted between 815/850 mm and 1200 mm (📖 p. 209). The distance is measured from the upper edge of the tabletop (1) to the floor (2).

Fig. 141: Adjusting the working height (2)

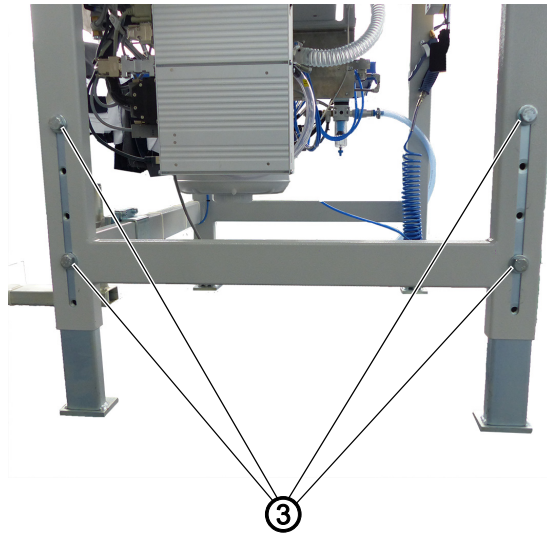

(3) - Screws

Fig. 142: Adjusting the working height (3)

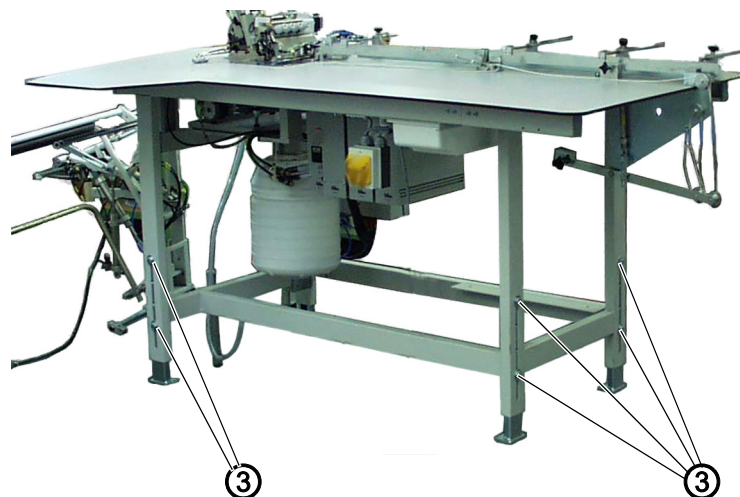

(3) - Screws
(Example: 1281)



To adjust the working height:

1. Loosen the screws (3) on the stand bars.
2. Adjust the tabletop to the desired height.



Important

Pull out or push in the tabletop evenly at both sides to prevent it from jamming.

3. Tighten the screws (3).

7.4 Assembling the reel stand

Fig. 143: Assembling the reel stand

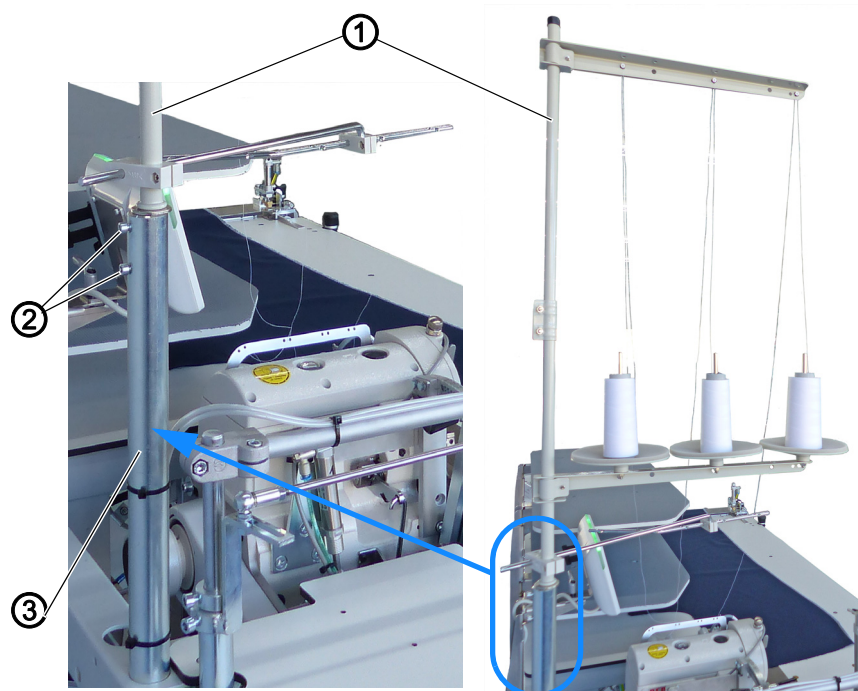

(1) - Reel stand tube
(2) - Screws

(3) - Holder



To assemble the reel stand:

1. Insert the reel stand tube (1) into the holder (3).
2. Tighten the screws (2).

7.5 Adjusting the knee button

Fig. 144: Adjusting the knee button (1)

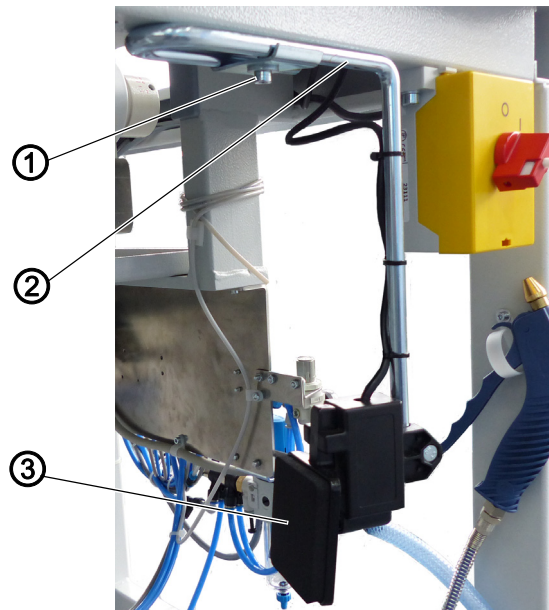

(1) - Screw
 (2) - Rod

(3) - Knee button



To move the knee button to the right/left:

1. Loosen the screw (1).
2. Slide the rod (2) to the right/left.
3. Tighten the screw (1).

Fig. 145: Adjusting the knee button (2)

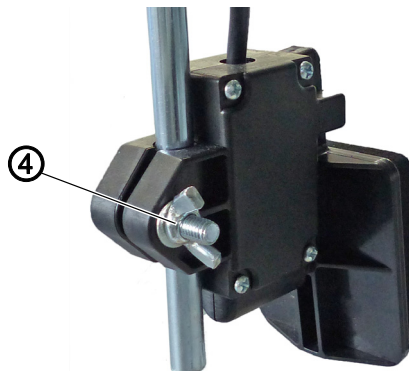

(4) - Wing screw



To move the knee button up/down:

1. Loosen the wing screw (4).
2. Slide the knee button (3) on the rod (2) up/down.
3. Turn the knee button (3) on the rod (2) sideways and even out the position as well.
4. Tighten the wing screw (4).



Information

Select the position of the knee button (3) such that the corresponding user can effortlessly press the knee button (3) with their knee while standing in front of the sewing table.

7.6 Assembling the flip stacker (optional)

Fig. 146: Assembling the flip stacker (1)

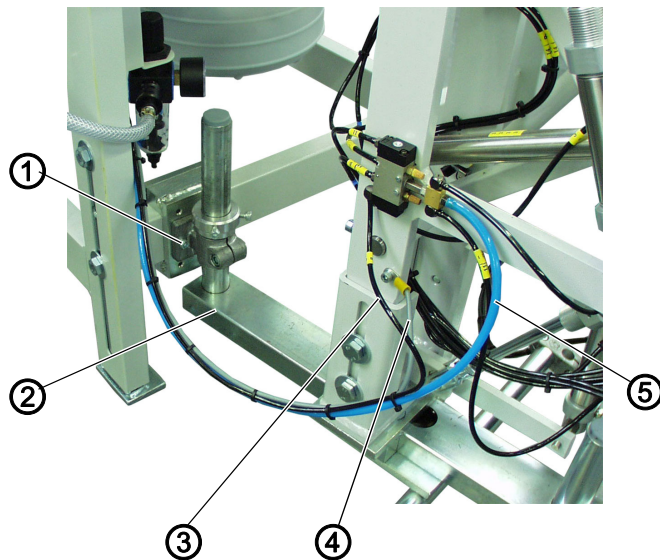

(1) - Screws

(2) - Holder

(3) - Pneumatic hose

(4) - Grounding wire

(5) - Pneumatic hose



To assemble the flip stacker:

1. Move the flip stacker with holder (2) up to the stand of the sewing unit.
 2. Tighten the holder (2) to the stand of the sewing unit using the screws (1).
- ⚠ Do not tighten the screws (1) all the way yet.

Fig. 147: Assembling the flip stacker (2)

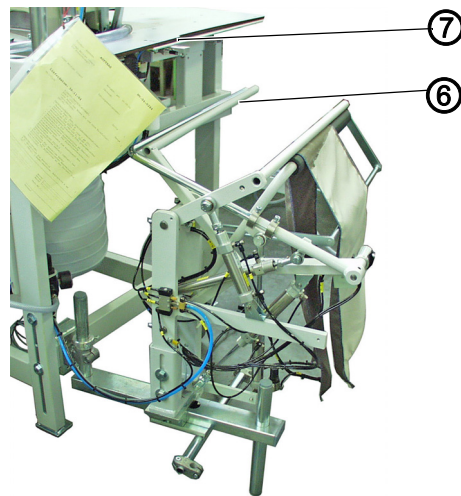

(6) - Smoother

(7) - Edge of the tabletop



3. Align the flip stacker such that the smoother (6) is parallel to the edge of the tabletop (7).
4. Tighten the screws (1).
5. Tighten the grounding wire (4) to the flip stacker.
6. Fit pneumatic hose (3) and (5) onto the pneumatic distributor.

7.7 Assembling the alternating stacker (optional)

Fig. 148: Assembling the alternating stacker (1)

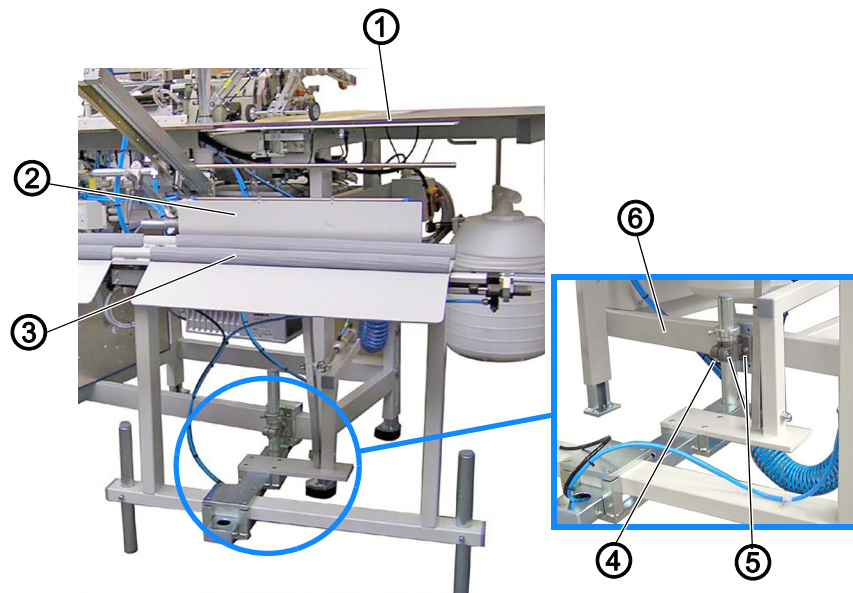

(1) - Edge of the tabletop

(2) - Stacking clamp

(3) - Alternating stacker

(4) - Holder

(5) - Screws

(6) - Stand of the sewing unit



To assemble the alternating stacker:

1. Move the alternating stacker (3) with holder (4) up to the stand of the sewing unit (6).
2. Tighten the holder (4) to the stand of the sewing unit (6) using the screws (5).
- ↩ Do not tighten the screws (5) all the way yet.
3. Align the alternating stacker (3) such that it is parallel to the edge of the tabletop (1) on the sewing table.
4. Tighten the screws (5).

Fig. 149: Assembling the alternating stacker (2)

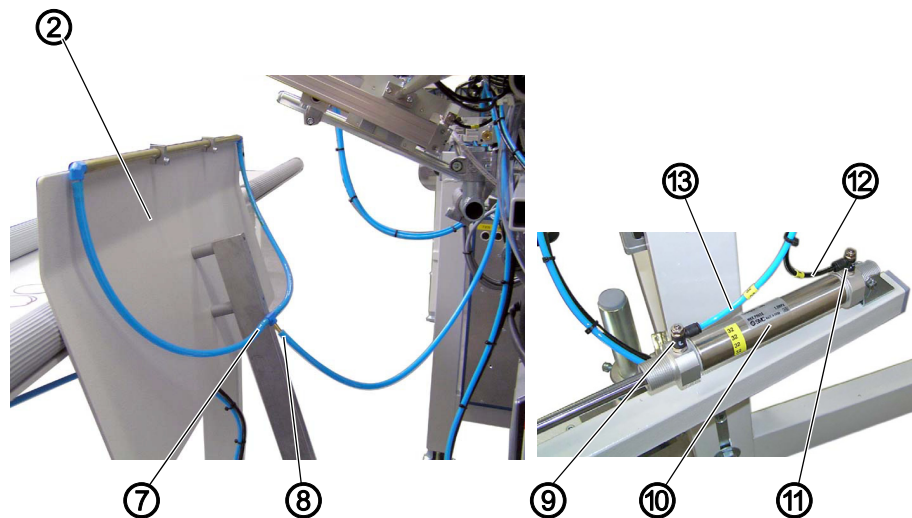

- (2) - Stacking clamp
- (7) - Pneumatic distributor
- (8) - Pneumatic hose
- (9) - Pneumatic valve

- (10) - Cylinder
- (11) - Pneumatic valve
- (12) - Black pneumatic hose
- (13) - Blue pneumatic hose



5. Fit the pneumatic hose (8) on the pneumatic distributor (7) of the stacking clamp (2).
6. Fit the pneumatic hoses on the cylinder.
 - Fit the black pneumatic hose (12) on the pneumatic valve (11)
 - Fit the blue pneumatic hose (13) on the pneumatic valve (9)

Fig. 150: Assembling the alternating stacker (3)

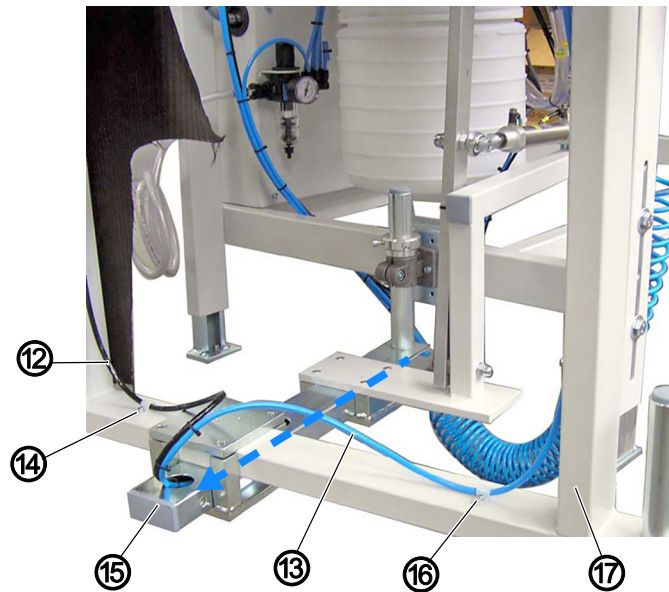

- | | |
|-------------------------------------|------------------------------------|
| (12) - Black pneumatic hose | (15) - Bar |
| (13) - Blue pneumatic hose | (16) - Blue pneumatic hose secured |
| (14) - Black pneumatic hose secured | (17) - Stand |



7. Feed the black and blue pneumatic hoses (12+13) through the bar (15) in arrow direction.
8. Properly route the pneumatic hoses upwards on the stand (17) and secure them carefully using clips/cable ties.
 - Secure the black pneumatic hose (14) towards the left
 - Secure the blue pneumatic hose (16) towards the right

Fig. 151: Assembling the alternating stacker (4)

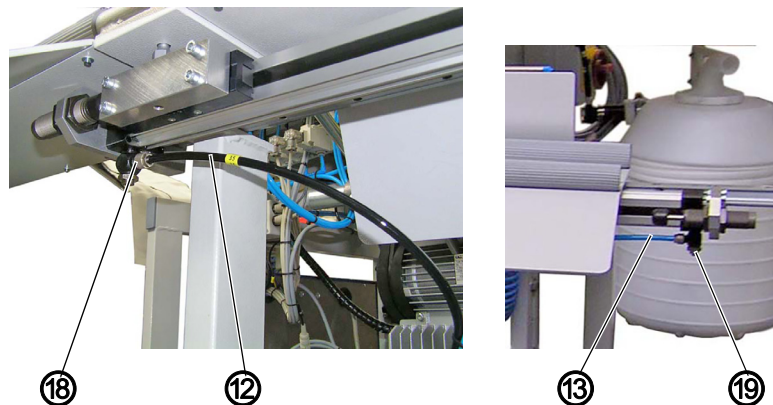

- | | |
|-----------------------------|------------------------|
| (12) - Black pneumatic hose | (18) - Pneumatic valve |
| (13) - Blue pneumatic hose | (19) - Pneumatic valve |



9. Fit the black pneumatic hose (12) on the pneumatic valve (18).
10. Fit the blue pneumatic hose (13) on the pneumatic valve (19).

7.8 Delivery table

7.8.1 Assembling the delivery table 1280

Fig. 152: Assembling the delivery table 1280 (1)



(1) - side delivery table

The sewing unit 1280 is equipped with a side delivery table (1). It is advisable to assemble this side delivery table (1) on the left side to allow for a smooth sewing process.

Fig. 153: Assembling the delivery table 1280 (2)

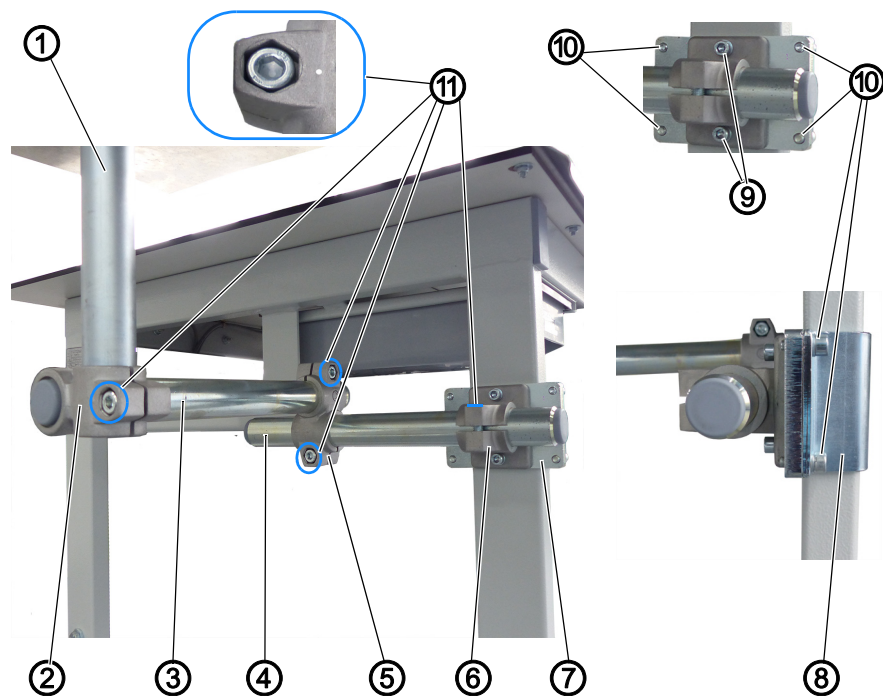

- (1) - side delivery table
 (2) - Holder
 (3) - Bar
 (4) - Bar
 (5) - Double holder

- (6) - single holder
 (7) - Metal plate
 (8) - Metal bracket
 (9) - Screws
 (10) - Screws
 (11) - Screws



To assemble the side delivery table:

1. Place the single holder (6) on the metal plate (7).
2. Tighten the screws (9).
3. Approaching from the direction of the sewing table, hold up the metal bracket (8) on the table leg at the desired height.
4. Hold the metal plate (7) against it from the outer side.
5. Tighten the screws (10).
6. Slightly loosen the screws (11) in their respective holder (2), (5), and (6).
 ↳ You need to do this so that you can insert the corresponding bars (3) and (4).
7. Slide the bar (4) into the pull holder (6).
8. Slide the double holder (5) onto the bar (4).
9. Slide the bar (3) into the double holder (5).
10. Slide the delivery table (1) into the holder (2).
11. Check and, if necessary, correct the position of the bars (3) and (4).
12. Tighten the screws (12) in their respective holder (2), (5), and (6).

7.8.2 Assembling the delivery table 1281

Fig. 154: Assembling the delivery table 1281

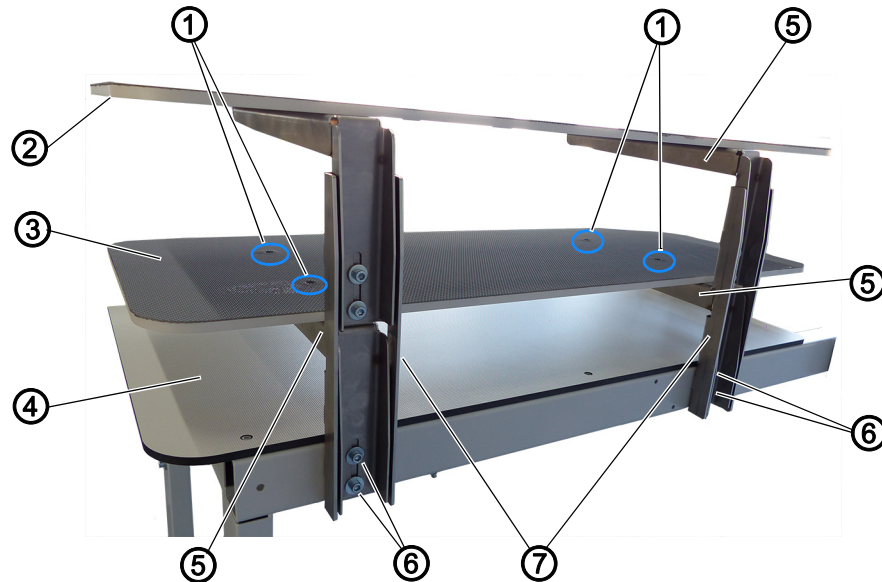

- | | |
|----------------------------|------------------------|
| (1) - Screws | (5) - Support brackets |
| (2) - Upper delivery table | (6) - Screws |
| (3) - Lower delivery table | (7) - Track |
| (4) - Sewing table | |

The sewing unit is equipped with the lower delivery table (3). The additional option with a dual delivery table is complemented by the upper delivery table (2).



To assemble the delivery table:

1. Slide the support brackets (5) into the track (7) from the direction of the sewing table (4).
2. Tighten the screws (6).
3. Repeat the steps 1. to 2. for the 2nd side.
4. Place the lower delivery table (3) on the support brackets (5).
5. Tighten the screws (1).
6. To assemble the upper delivery table (2), repeat the steps 1. to 5.

Aligning the delivery table



To align the delivery table:

7. Loosen the screws (6)
8. Adjust the delivery table (2) to the desired height.

9. Tighten the screws (6).
10. To align the upper delivery table (2), repeat the steps 7. to 9.



Important

Move the delivery table (2)/(3) on both sides at the same time to keep it from slanting.

7.9 Assembling the clamping stacker tray extension (optional)

Fig. 155: Assembling the clamping stacker tray extension

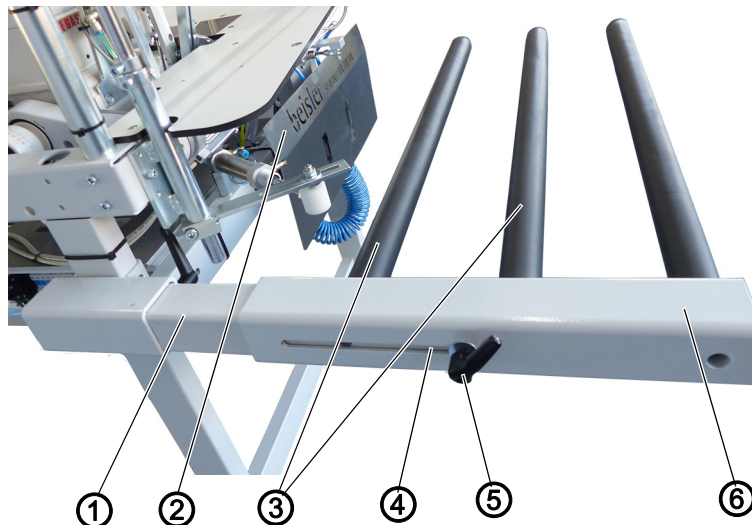

- | | |
|------------------------|----------------------|
| (1) - Holder | (4) - Slot |
| (2) - Clamping stacker | (5) - Lever |
| (3) - Dual tray | (6) - Tray extension |

By default, the base model machine is equipped with the dual tray (3) for the clamping stacker (2). An additional arm can be added as a tray extension (6) if the sewing material is large/long.



To assemble the tray extension:

1. Slide the tray extension (6) onto the holder (1).
2. Set the tray extension to the desired distance.
 - The minimum/maximum distance is preset by the slot (4).
3. Use the lever (5) to lock the tray extension (6) in place on the holder (1).

7.10 Electrical connection

DANGER



Risk of death from live components!

Unprotected contact with electricity can result in serious injuries or death.

Only qualified specialists may perform work on electrical equipment.



Important

The voltage on the type plate of the sewing motor must correspond to the mains voltage.

Establishing the electrical connection



To establish the electrical connection:

1. Connect the power plug.

7.11 Pneumatic connection

NOTICE

Property damage from oily compressed air!

Oil particles in the compressed air can cause malfunctions of the machine and soil the sewing material.

Ensure that no oil particles enter the compressed air supply.

NOTICE

Property damage from incorrect adjustment!

Incorrect system pressure can result in damage to the machine.

Ensure that the machine is only used when the system pressure is set correctly.

The pneumatic system of the machine and of the additional equipment must be supplied with dry and oil-free compressed air. The supply pressure must lie between 8 and 10 bar.

7.11.1 Assembling the compressed air maintenance unit



To assemble the compressed air maintenance unit:

1. Connect the connection hose to the compressed air supply using a hose coupling R 1/4".

7.11.2 Adjusting the operating pressure

NOTICE

Property damage from incorrect adjustment!

Incorrect operating pressure can result in damage to the machine.

Ensure that the machine is only used when the operating pressure is set correctly.



Proper setting

Refer to the **Technical Data** ( p. 209) chapter for the permissible operating pressure. The operating pressure cannot deviate by more than ± 0.5 bar.

Check the operating pressure on a daily basis.

Fig. 156: Adjusting the operating pressure

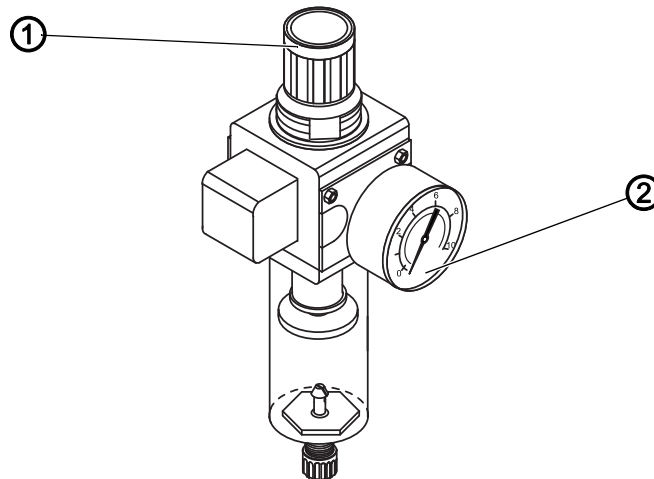

(1) - Pressure regulator

(2) - Pressure gage



To adjust the operating pressure:

1. Pull the pressure regulator (1) up.
2. Turn the pressure regulator until the pressure gage (2) indicates the proper setting:
 - Increase pressure = turn clockwise
 - Reduce pressure = turn counterclockwise
3. Push the pressure regulator (1) down.

7.12 Performing a test run

When setup is complete, perform a test run to check the functionality of the machine.

8 Decommissioning

WARNING



Risk of injury from a lack of care!

Serious injuries may occur.

ONLY clean the machine when it is switched off.
Allow ONLY trained personnel to disconnect the machine.

CAUTION



Risk of injury from contact with oil!

Oil can cause a rash if it comes into contact with skin.

Avoid skin contact with oil.
If oil has come into contact with your skin, wash the affected areas thoroughly.



To decommission the machine:

1. Switch off the machine.
2. Unplug the power plug.
3. If applicable, disconnect the machine from the compressed air supply.
4. Wipe up and remove residual oil from the oil pan using a cloth.
5. Cover the control panel to protect it from soiling.
6. Cover the control to protect it from soiling.
7. Cover the entire machine if possible to protect it from contamination and damage.

9 Disposal

CAUTION



Risk of environmental damage from improper disposal!

Improper disposal of the machine can result in serious environmental damage.

ALWAYS comply with the national regulations regarding disposal.

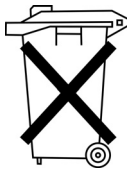

The machine must not be disposed of in the normal household waste.

The machine must be disposed of in a suitable manner in accordance with all applicable national regulations.

When disposing of the machine, be aware that it consists of a range of different materials (steel, plastic, electronic components, etc.). Follow the national regulations when disposing these materials.

10 Troubleshooting

10.1 Customer Service

Contact for repairs and issues with the machine:

Dürkopp Adler GmbH

Potsdamer Str. 190
33719 Bielefeld, Germany

Tel. +49 (0) 180 5 383 756

Fax +49 (0) 521 925 2594

Email: service@duerkopp-adler.com

Internet: www.duerkopp-adler.com



10.2 Messages of the software

Please contact customer service if an error occurs that is not described here. Do not attempt to correct the error yourself.

Three groups of messages

Group	Description
Error	Serious error. Switch off the control and eliminate the error.
Warning	Eliminate the cause of the warning. The control will operate normally.
Information	Press the OK button. Operation can continue. It is possible that only emergency operating features will be available.

Error, warning and information messages

Group	Number	Description	Corrective
Error	1000	Sewing motor encoder plug X5B (Sub-D, 9-pin) not connected	<ul style="list-style-type: none"> • Connect encoder cable to the control, use correct connection
Error	1001	Sewing motor error Sewing motor plug (AMP) not connected	<ul style="list-style-type: none"> • Check connection and plug in, if necessary • Test sewing motor phases (R= 2.8Ohm, high impedance to PE) • Replace sewing motor • Replace the control
Error	1002	Sewing motor insulation error	<ul style="list-style-type: none"> • Check motor phase and PE for low-impedance connection • Replace sewing motor
Error	1004	Incorrect sewing motor direction of rotation	<ul style="list-style-type: none"> • Replace sewing motor • Check motor plug assignment and change it if necessary • Check wiring in machine distributor and change it, if necessary • Measure motor phases and check for value
Error	1005	Motor blocked	<ul style="list-style-type: none"> • Remedy creep in the sewing machine
Error	1006	Maximum speed exceeded	<ul style="list-style-type: none"> • Replace sewing motor • Carry out a reset • Check machine class
Error	1008	Sewing motor encoder error	<ul style="list-style-type: none"> • Replace sewing motor
Error	1011	Encoder Z pulse missing	<ul style="list-style-type: none"> • Switch off the control. Turn handwheel and switch on the control again. • If error is not corrected, replace sewing motor.
Error	1052	Sewing motor overcurrent, internal current rise > 25A	<ul style="list-style-type: none"> • Replace the control
Error	1053	Sewing motor overcurrent	<ul style="list-style-type: none"> • Replace the control
Error	1054	Internal short circuit	<ul style="list-style-type: none"> • Replace the control
Error	1055	Sewing motor overload	<ul style="list-style-type: none"> • Remedy creep in the machine • Replace sewing motor
Error	1058	Sewing motor speed not achieved	<ul style="list-style-type: none"> • Remedy creep in the machine • Update software • Replace the control • Replace sewing motor
Error	1120	Sewing motor initialisation error	<ul style="list-style-type: none"> • Update software • Replace the control
Error	1310	Sewing motor communication error	<ul style="list-style-type: none"> • Update software • Replace the control
Error	1320	Sewing motor general	<ul style="list-style-type: none"> • Update software • Replace the control • Replace sewing motor

Group	Number	Description	Corrective
Error	2114	Stepper motor X Functional error	<ul style="list-style-type: none"> • Update software • Check the stepper motor • Replace the control
Error	2152	Stepper motor X Overcurrent	<ul style="list-style-type: none"> • Update software • Check the stepper motor
Error	2156	Stepper motor X Overtemperature	<ul style="list-style-type: none"> • Update software • Check the stepper motor
Error	2214	Stepper motor Y Functional error	<ul style="list-style-type: none"> • Update software • Check the stepper motor • Replace the control
Error	2252	Stepper motor Y Overcurrent	<ul style="list-style-type: none"> • Update software • Check the stepper motor
Error	2256	Stepper motor Y Overtemperature	<ul style="list-style-type: none"> • Update software • Check the stepper motor
Error	2314	Stepper motor Z Functional error	<ul style="list-style-type: none"> • Update software • Check the stepper motor • Replace the control
Error	2352	Stepper motor Z Overcurrent	<ul style="list-style-type: none"> • Update software • Check the stepper motor
Error	2356	Stepper motor Z Overtemperature	<ul style="list-style-type: none"> • Update software • Check the stepper motor
Error	2914	Stepper motor calculation error	<ul style="list-style-type: none"> • Update software
Error	3100	AC-RDY timeout, DC link voltage has not reached the defined threshold.	<ul style="list-style-type: none"> • Check mains voltage • If mains voltage is OK, replace control unit.
Error	3101	High voltage error, mains voltage > 290V for a long time.	<ul style="list-style-type: none"> • Check mains voltage • Stabilize the mains voltage
Error	3102	Low voltage error (2 nd threshold) (mains voltage < 150V AC)	<ul style="list-style-type: none"> • Check mains voltage • Stabilize the mains voltage
Information	3103	Low voltage warning (1 st threshold) (mains voltage < 180V AC)	<ul style="list-style-type: none"> • Check mains voltage • Stabilize the mains voltage
Warning	3104	Pedal is not in position 0	<ul style="list-style-type: none"> • Take your foot off the pedal when switching on the controller • Check the pedal setting
Error	3105	U24V short circuit	<ul style="list-style-type: none"> • Disconnect 37-pin plug, if error 3105 persists, replace control unit. • Test inputs/outputs for 24V short circuit
Error	3106	U24V (I ² T) overload	<ul style="list-style-type: none"> • One or more of the magnets defective
Information	3107	Foot pedal not connected	<ul style="list-style-type: none"> • Connect pedal to enable starts by foot pedal and intermediate stops.
Information	3108	Speed limited due to insufficient mains voltage	<ul style="list-style-type: none"> • Check mains voltage
Error	3131	U60V short circuit	<ul style="list-style-type: none"> • Update software • One or several stepper motors defective • Replace the control

Group	Number	Description	Corrective
Error	3132	Overload U60V	<ul style="list-style-type: none"> • Update software • One or several stepper motors defective • Replace the control
Information	3150	Maintenance required	<ul style="list-style-type: none"> • Information on lubricating the machine (📖 p. 176) • See the machine's service manual.
Warning	3151	Maintenance required	<ul style="list-style-type: none"> • Service is urgently required (📖 p. 173) • See the machine's service manual
Warning	3210	Thread breakage on Monitor 1	<ul style="list-style-type: none"> • The thread monitor 1 reports a thread breakage. Please check.
Warning	3211	Thread breakage on Monitor 2	<ul style="list-style-type: none"> • The thread monitor 2 reports a thread breakage. Please check.
Warning	3212	Thread breakage on Monitor 3	<ul style="list-style-type: none"> • The thread monitor 2 reports a thread breakage. Please check.
Error	5950	Flash memory error	<ul style="list-style-type: none"> • Update software • Replace the control
Error	5951	Error No SD card	<ul style="list-style-type: none"> • Update software • Replace the control
Error	6353	Communication failure internal EEPROM	<ul style="list-style-type: none"> • Switch off the control unit, wait until the LEDs have gone out, switch on the control unit.
Error	6354	Communication failure external EEPROM	<ul style="list-style-type: none"> • Switch off the control unit, wait until the LEDs have gone out, check the machine ID connection. Switch the control unit on again.
Information	6360	No valid data on external EEPROM	<ul style="list-style-type: none"> • Update software
Information	6361	No external EEPROM connected	<ul style="list-style-type: none"> • Connect machine ID
Information	6362	No valid data on internal EEPROM	<ul style="list-style-type: none"> • Check machine ID connection • Switch off the control, wait until the LEDs are off and then switch on again. • Update software
Information	6363	No valid data on internal and external EEPROM (emergency operating features only)	<ul style="list-style-type: none"> • Check machine ID connection • Switch off the control, wait until the LEDs are off and then switch on again. • Update software
Information	6364	No valid data on internal EEPROM and external EEPROM not connected (emergency operating features only)	<ul style="list-style-type: none"> • Check machine ID connection • Switch off the control, wait until the LEDs are off and then switch on again. • Update software
Information	6365	Internal EEPROM defective	<ul style="list-style-type: none"> • Replace the control

Group	Number	Description	Corrective
Information	6366	Internal EEprom defective and external data not valid (emergency operating features only)	<ul style="list-style-type: none"> • Replace the control
Information	6367	Internal EEprom defective and external EEprom not connected (emergency operating features only)	<ul style="list-style-type: none"> • Replace the control
Error	7200	CAN internal communication error	<ul style="list-style-type: none"> • Software update • Replace the control
Error	7651	UART control panel interface communication error	<ul style="list-style-type: none"> • Software update • Replace the control
Error	7655	UART control panel interface buffer error	<ul style="list-style-type: none"> • Software update • Replace the control
Error	7657	UART control panel interface hardware error	<ul style="list-style-type: none"> • Software update • Replace the control
Information	7801	Software version error	<ul style="list-style-type: none"> • Software update • Replace the control
Information	7802	Software update error	<ul style="list-style-type: none"> • Repeat software update • Replace the control
Error	8401	Watchdog	<ul style="list-style-type: none"> • Perform a software update on the control unit • Replace the control
Error	8402	Internal error	<ul style="list-style-type: none"> • Perform a software update on the control unit • Replace the control
Error	8501	Software protection	<ul style="list-style-type: none"> • The DA tool must always be used for the software update.
Error	8502	Parameter versions not compatible	<ul style="list-style-type: none"> • Software update
Warning	9400	Start photocell is occupied	<ul style="list-style-type: none"> • Release the start photocell
Information	9400	Photocell covered	<ul style="list-style-type: none"> • Remove material • Check photocell
Information	9923	Control panel software is not updated	<ul style="list-style-type: none"> • Update the software of the control panel
Warning	9947	Machine shuts down!	<ul style="list-style-type: none"> • Check power supply • Switch on the machine
Information	9948	You have reached your number!	<ul style="list-style-type: none"> • You have reached your desired number - please enter a new value for the piece counter.

Group	Number	Description	Corrective
Information	9949	No connection between control and control panel	<ul style="list-style-type: none"> • Check plug connection of cable between control panel and control box • Replace cable between control box and control panel • Update the software of the control box • Update the software of the control panel • Change control box • Change control panel
Information	9950	Control box software is not updated	<ul style="list-style-type: none"> • Update Control box software
Information	9951	Check Foot Pedal	<ul style="list-style-type: none"> • Attention: Make sure that a pedal is connected to the machine and activate pedal in machine configuration 1.1.6.

10.3 Errors in sewing process

Error	Possible causes	Corrective
Unthreading at seam beginning	Needle thread tension is too firm	Check needle thread tension
Thread breaking	Needle thread and hook thread have not been threaded correctly	Check threading path
	Needle is bent or sharp-edged	Replace needle
	Needle is not inserted correctly into the needle bar	Insert the needle correctly into the needle bar
	The thread used is unsuitable	Use recommended thread
	Thread tensions are too tight for the thread used	Check thread tensions
	Thread-guiding parts, such as thread tube, thread guide or thread take-up disk, are sharp-edged	Check threading path
	Throat plate, hook or spread have been damaged by the needle	Have parts reworked by qualified specialists
Skip stitches	Needle thread and hook thread have not been threaded correctly	Check threading path
	Needle is blunt or bent	Replace needle
	Needle is not inserted correctly into the needle bar	Insert the needle correctly into the needle bar
	The needle thickness used is unsuitable	Use recommended needle thickness
	The reel stand is assembled incorrectly	Check the assembly of the reel stand
	Thread tensions are too tight	Check thread tensions
	Throat plate, hook or spread have been damaged by the needle	Have parts reworked by qualified specialists

Error	Possible causes	Corrective
Loose stitches	Thread tensions are not adjusted to the sewing material, the sewing material thickness or the thread used	Check thread tensions
	Needle thread and hook thread have not been threaded correctly	Check threading path
Needle breakage	Needle thickness is unsuitable for the sewing material or the thread	Use recommended needle thickness

11 Technical data

Data and characteristic values

Technical data	Unit	Submodels	
		1280-7	1281-7
Machine type		Sewing unit for the automatic and semi-automatic closing of long seams.	
Stitch type		401 2-thread/515 4-thread/ 516 5-thread	
Hook type		Chainstitch hook, Overlock hook	
Number of needles		1/2	
Needle system		B27	
Needle strength	[Nm]	80 - 110	
Thread strength	[Nm]	up to 80	
Stitch length	[mm]	0.5-3.5	
Speed maximum	[min ⁻¹]	5500/6500	
Speed on delivery	[min ⁻¹]	6000/5500 depending on the delivered sewing machine head	
Seam width	[mm]	9, 10, 11, 12	
Sewing material		light/medium	
Mains voltage	[V]	1x230	
Mains frequency	[Hz]	50/60	
Operating pressure	[bar]	6	
Length	[mm]	850	2300
Width	[mm]	950	1500
Height of base unit	[mm]	1700	1750
Table height	[mm]	815-1200	850-1200
Weight	[kg]	120	206
Rated power	[kVA]	0.9	0.9
Power input	[kVA]	0.9	0.9

11.1 Requirements for fault-free operation

Compressed air quality must conform to ISO 8573-1: 2010 [7:4:4]

11.2 Recommended threads

Needle system: B27

Recommended needle thickness:

- Nm 80 for extra thin sewing material
- Nm 90 for thin sewing material
- Nm 100 for moderately heavy sewing material
- Nm 110 for heavy sewing material

High sewing security and good sewability are achieved with the following core spun threads:

- Two-ply polyester endless polyester core-spun (e.g. Epic Poly-Poly, Rasant x, Saba C, ...)
- Two-ply polyester endless polyester core-spun (e.g. Frikka, Koban, Rasant, ...)

If these threads are not available, the polyester fiber or cotton threads listed in the table can also be sewn.

Often two-ply core spun threads are offered by the thread manufacturers with the same description as three-ply polyester fiber threads (3cyl.-spun). This causes uncertainty with regard to twisting and thread thickness.

When in doubt, unravel the thread and check whether it is twisted 2- or 3-ply. The label no. 120 on the thread reel of a core spun thread corresponds e.g. to the thread size Nm 80/2 (see table values in brackets).

In case of monofilament threads you can use needle threads and hook threads of the same thickness. The best results are achieved with soft and elastic threads (software) of the thread thickness 130 Denier.

Recommended thread thicknesses

Needle thickness Nm	Core spun thread		Core spun thread	
	Needle thread Polyester - endless Label no.	Hook thread Polyester - core spun Label no.	Needle thread Polyester - endless Label no.	Hook thread Cotton - core spun Label no.
80 90 100-110	120 (NM 80/2) 100 (Nm 65/2)	120 (NM 80/2) 100 (Nm 65/2)	120 (NM 80/2) 100 (Nm 65/2)	120 (NM 80/2) 100 (Nm 65/2)
Needle thickness Nm	Polyester filament thread (3cyl.-spun)		Cotton thread	
	Needle thread	Hook thread	Needle thread	Hook thread
80 90 100-110	Nm 120/3 Nm 80/3-120/3 Nm 70/3-100/3	Nm 120/3 Nm 80/3-120/3 Nm 70/3-100/3	NeB 60/3-80/3 NeB 50/3-70/3 NeB 40/3-60/3 (1NeB = 1.6934 Nm)	NeB 60/3-80/3 NeB 50/3-70/3 NeB 40/3-60/3 (1NeB = 1.6934 Nm)



DÜRKOPP ADLER GmbH
Potsdamer Str. 190
33719 Bielefeld
Germany
Phone: +49 (0) 521 925 00
Email: service@duerkopp-adler.com
www.duerkopp-adler.com