

## Conversion instructions class 221 to DAC-Classic



All Rights Reserved

Property of Dürkopp Adler GmbH and subject to copyright. Any use of this content, or part of it, is prohibited without prior written permission of Dürkopp Adler GmbH  
Copyright © Dürkopp Adler GmbH 2022

# Table of contents

---

|       |   |   |
|-------|---|---|
| 1     | Components of the kit .....                         | 4 |
| 2     | Installation instructions .....                     | 5 |
| 2.1   | Removing the former control unit .....              | 5 |
| 2.2   | Mechanical installation of the components.....      | 5 |
| 2.2.1 | Mounting the DAC-Classic .....                      | 5 |
| 2.2.2 | Mounting the motor.....                             | 5 |
| 2.2.3 | Mounting the synchronizer .....                     | 6 |
| 2.2.4 | Fixing the machine identification .....             | 7 |
| 2.2.5 | Mounting the set value initiator (foot pedal) ..... | 7 |
| 2.3   | Electric connection of the components.....          | 8 |
| 2.4   | Initial operation .....                             | 8 |
| 2.5   | Basic settings of parameters .....                  | 8 |

## 1 Components of the kit

Please check before you start the conversion to DAC-Classic, whether all the components of the kit **9889 022106 8S** are included in the delivery.

| Part number    | Amount | Designation                                  |
|----------------|--------|--|
| 0221 100223    | 1      | Hand wheel                                   |
| 9130 520493    | 1      | Pulley                                       |
| 0221 100200    | 1      | Belt guard                                   |
| 0999 211046    | 1      | V-belt                                       |
| 9850 221001    | 1      | Machine id                                   |
| 9800 210001 R  | 1      | Control unit                                 |
| 9800 170040    | 1      | Motor  |
| 9800 347003    | 1      | Position generator                           |
| 0220 100324    | 1      | Support for position generator               |
| 0791 221770 DE | 1      | Installation instructions                    |
| 0907 050144    | 1      | Grounding kit                                |
| 9401 000454    | 1      | Motor fixation                               |
| 9201 013767    | 3      | hexagonal screw, M8X35 (ISO 4014)            |
| 9330 300027    | 3      | Washer, R9 (ISO 7094)                        |
| 0725 000520 B  | 3      | Washer spring, A8 (DIN 127)                  |
| 9202 002487    | 4      | Fillister socket head screw M5x12 (ISO 4762) |
| 0068 150023    | 1      | Adjustment Ring                              |

## 2 Installation instructions



### CAUTION Risk of Injury!

Turn off the main switch and remove the plug from the mains before you start with the conversion.  
The conversion may only be carried out by qualified technicians.

### 2.1 Removing the former control unit

Before you start to mount the new motor package, the following components have to be removed first:

- the belt protection on the machine head
- the mounted motor together with motor base and belt
- the control unit with all cables (exception: remove the potential equalization cable only from the control unit, not from the machine head)
- the set value initiator including its bracket



Fig. 2: Control unit

### 2.2 Mechanical installation of the components

#### 2.2.1 Mounting the DAC-Classic

Mount the DAC-Classic control unit as shown in figure 2 with the delivered wood screws underneath the table top on the right front.

Fix the electric cables with strain relief and, if needed, nail clamps to protect them from mechanical strain.

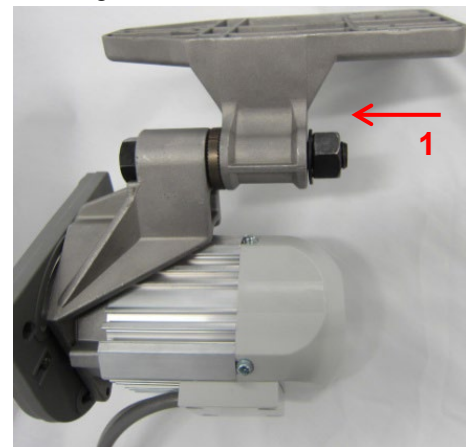

Fig. 3: Motor

#### 2.2.2 Mounting the motor

Screw the adapter and the rear side of the belt protection onto the motor (mind the cable exiting the motor).

Then, fix the motor as shown in figure 3 loosely onto the motor base. Upon mounting the motor base underneath the table top, make sure the motor pulley is parallel to the machine head pulley and is positioned in the center of the table cutout for the belt. Consult figure 4.

Tension the belt when tightening the screw of the motor base (fig. 3 No. 1). After this, refit the belt protection of the machine head.

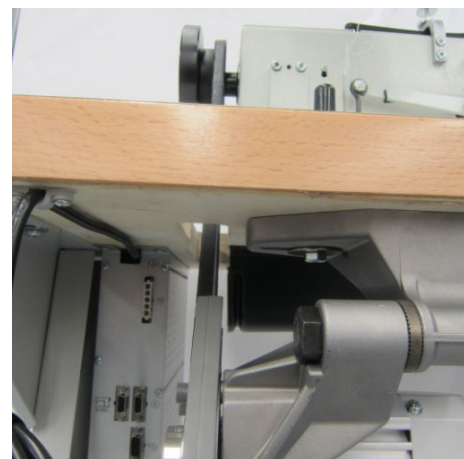

Fig. 4: Motor onto the machine

In order to prevent the belt from sliding off the pulley when the machine head is tilted, fit the adjustment ring in the position shown in figure 5.

Then refit the cover of the belt protection onto the motor. At this point, the mounting bracket of the synchronizer can be fixed on the belt protection of the machine head.

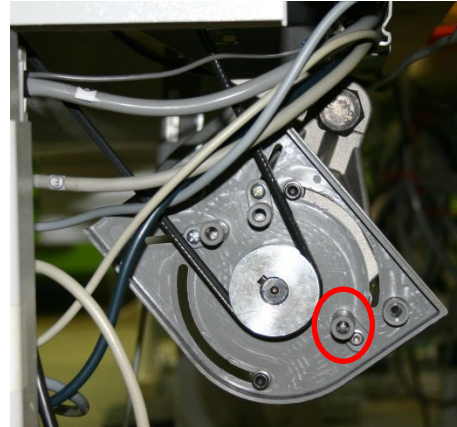

Fig. 5: Position adjustment ring

### 2.2.3 Mounting the synchronizer

Turn the hand wheel in running direction (towards the operator) until the needle tip comes as close as possible to the throat plate level, figure 6.

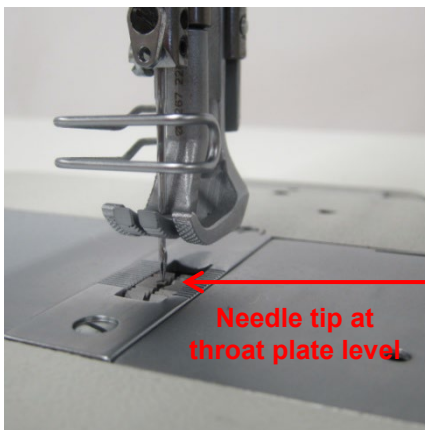

Fig. 6: Needle position

Screw the synchronizer onto the hand wheel so that the second stud screw in running direction comes in line with the marking on the synchronizer, figure 7.



Fig. 7: Synchronizer

Run the cables, making sure that they will not get in the way of moving parts.



**If the machine does not carry out the positioning correctly, the effected settings have to be compared with the installation instructions for the synchronizer and, if needed, repeated.**

#### 2.2.4 Fixing the machine identification

The machine identification can be placed at the cable duct on the rear table top edge. If you want to fix the machine identification elsewhere, make sure that it does not get in the way of moving parts!

#### 2.2.5 Mounting the set value initiator (foot pedal)

Fix the enclosed fixation bracket onto the table top as shown in figure 8. The cable of the set value initiator can be attached with the clip of the bracket.

Attach the connecting rods to the set value initiator and the pedal. Make sure that after mounting the angle between connecting rod and pedal is about 90°, see figure 8.

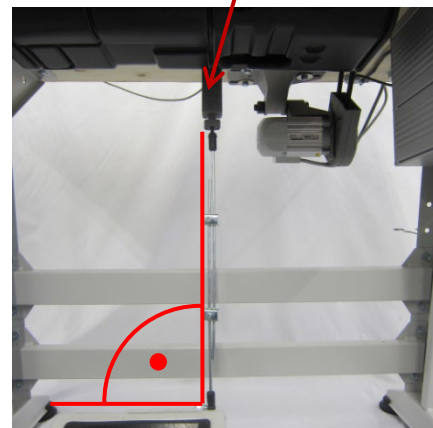

Fig. 8: Mounting the set value initiator

## 2.3 Electric connection of the components

Connect the cables of the motor, the encoder, the synchronizer, the set value initiator (foot pedal) and the machine id as shown in figure 9. Screw the potential equalization cable of the machine head and the motor cable onto the potential equalization of the control unit.

## 2.4 Initial operation

The control unit may now be connected to the mains. If all previous steps have been carried out as mentioned above, the machine is now ready for operation.

## 2.5 Basic settings of parameters

The control unit comes with a basic factory setting that allows for sewing without any additional parameter settings needed.

However, if you should need the parameters you can find them in the Download Area of [www.duerkopp-adler.com](http://www.duerkopp-adler.com) (number 0791 221900).

The adjustment of the settings is described in the manual delivered with the sewing drive. This document is also to be found in the Download Area of [www.duerkopp-adler.com](http://www.duerkopp-adler.com).

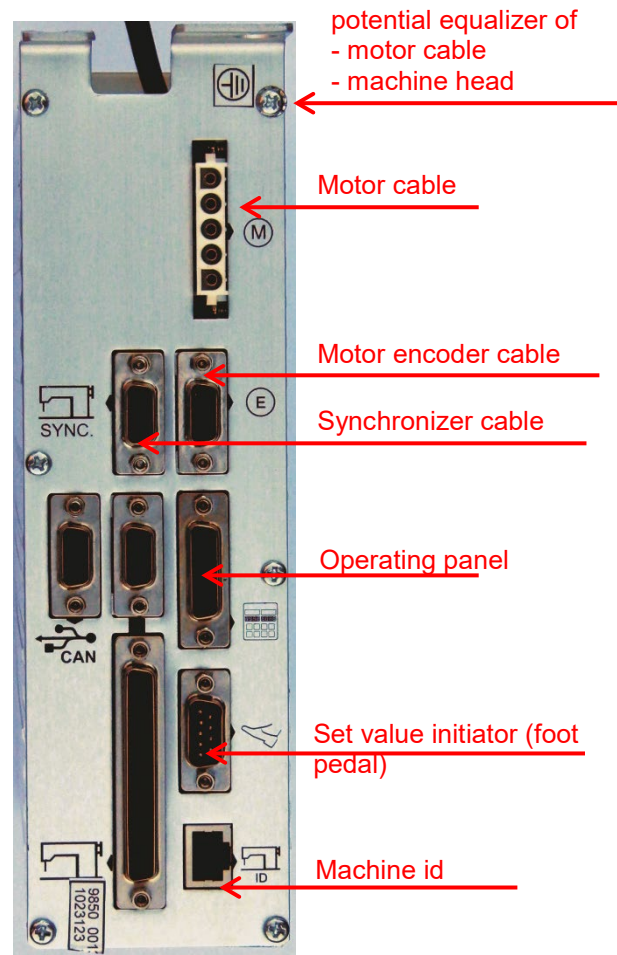

Fig. 9: Connection of the cables



**For your notes:**

**For your notes:**

**For your notes:**



DÜRKOPP ADLER GmbH  
Potsdamer Str. 190  
D-33719 Bielefeld  
Germany  
Phone +49 (0) 521 925 00  
E-Mail: [service@duerkopp-adler.com](mailto:service@duerkopp-adler.com)  
[www.duerkopp-adler.com](http://www.duerkopp-adler.com)