

267

零件列表

Parts List

267

Table of contents	Table / 图表	目录
Arm shaft	1	上轴
Upper feed, feed- and needle bar	2	上送料、下送料和针送料
Presser bar	3	压杆
Needle feed shaft	4	针送料轴
Feed regulator	5, 6	针距调节机构
Sewing foot lift system	7	抬压脚机构
Arm cover and pretension	8	机壳顶盖和过线预夹紧
Thread tension bearer	9, 10	夹线器
Bobbin winder	11	绕线器
Arm and face cover	12	机壳和面板
Bed plate	13	底板
Slide	14	推板
Hook and hook bearing	15, 16	旋梭和旋梭安装座
Belt pulley	17	皮带轮
Lower shaft	18	下轴
Lifter shaft, feed crank	19	抬牙和送料机构
Stand, maintenance unit	20	机架台板
Sewing lamp and transformer	21	缝纫灯和变压器
Motor package	22	马达包
Accessories	23, 24	附件盒
Sewing equipments		缝纫附件

All rights reserved.

Property of Dürkopp Adler and copyrighted. Reproduction or publication of the content in any manner, even in extracts, without prior written permission of Dürkopp Adler, is prohibited.

版权所有，不许翻印

版权和产权归杜克普爱华股份公司所有。未经杜克普爱华股份公司书面许可，禁止以任何方式翻印或复印本内容，包括摘要。

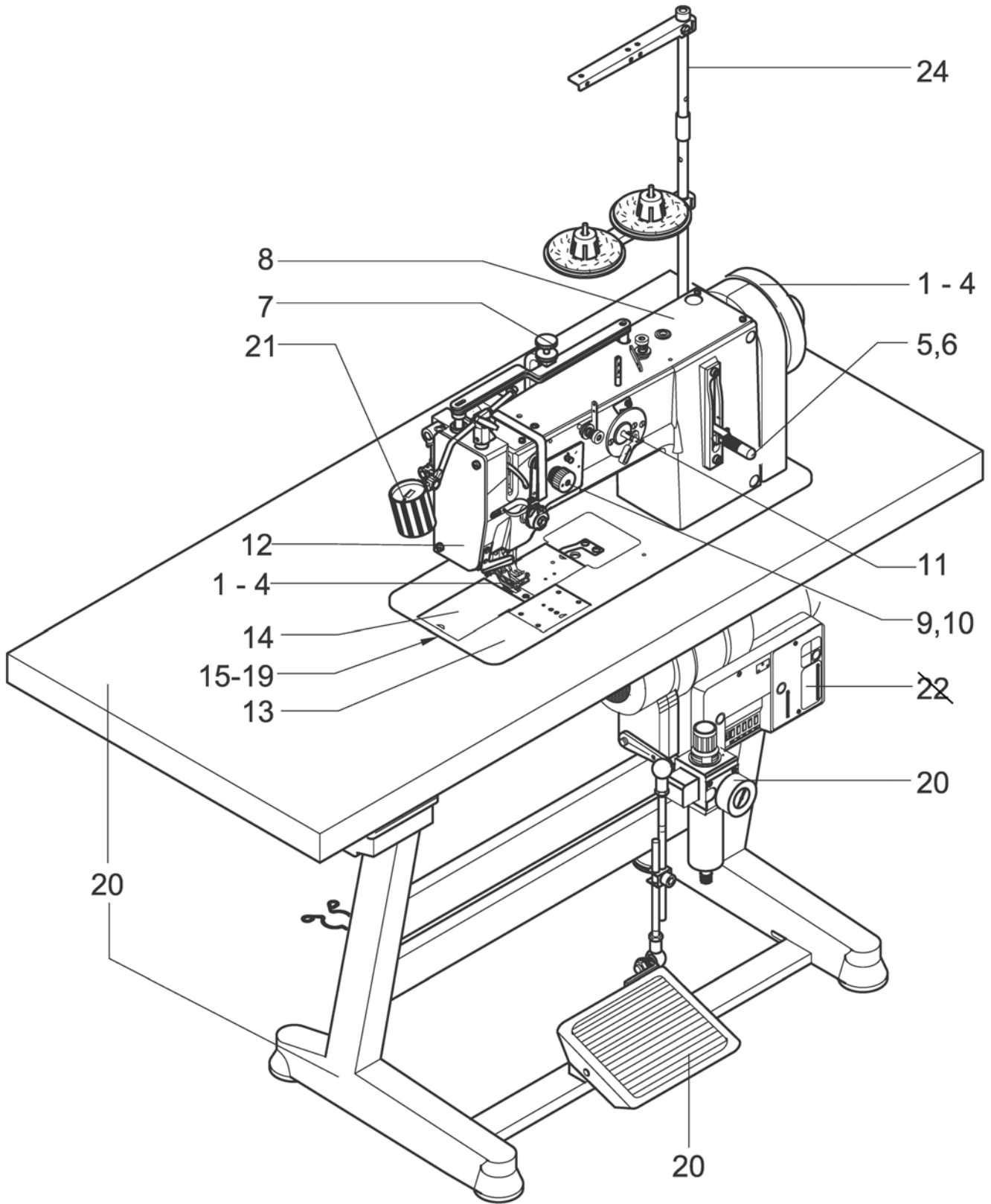

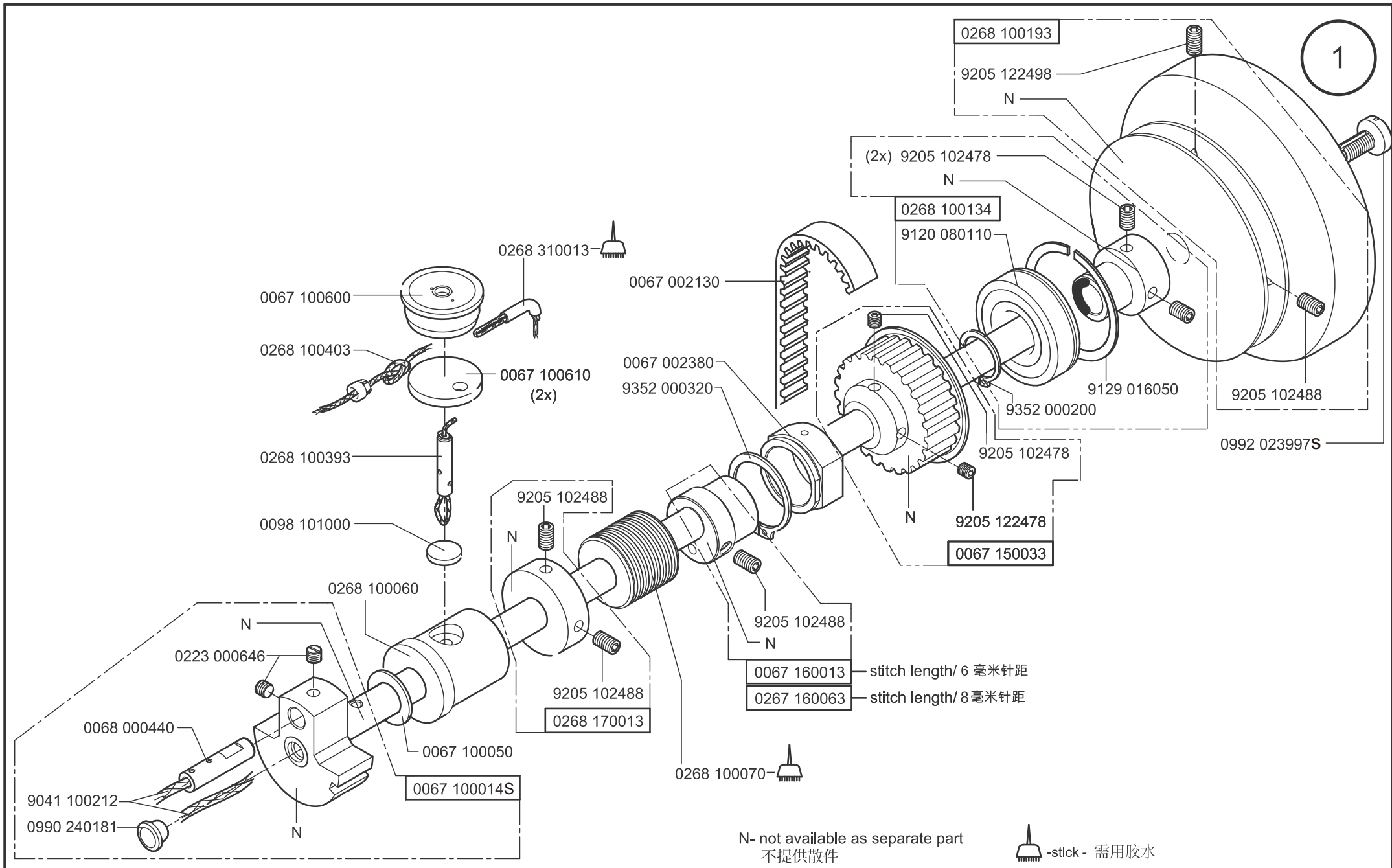

Scale / Scale 50%

CI. 267

Edition / 版本 04.2016

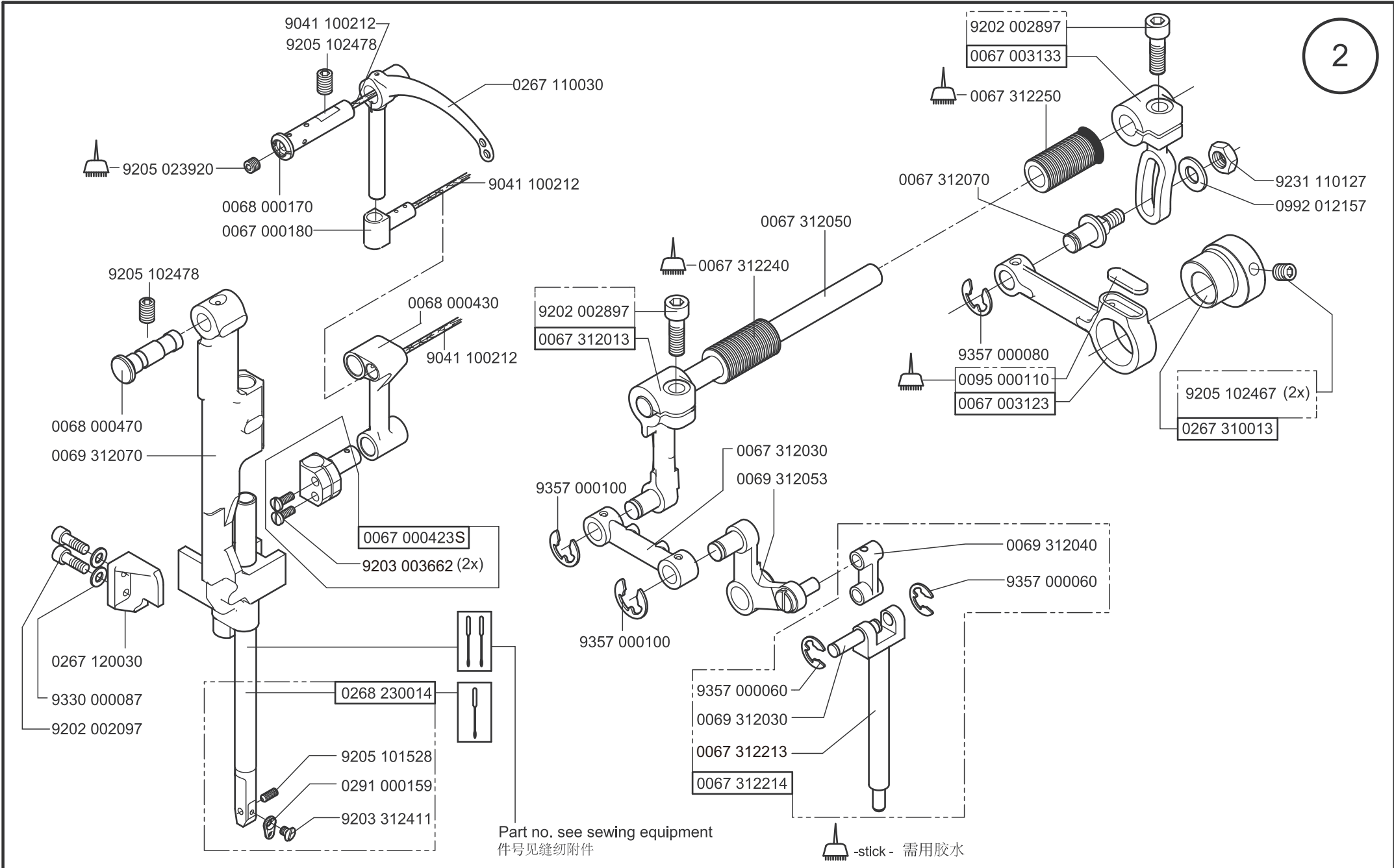

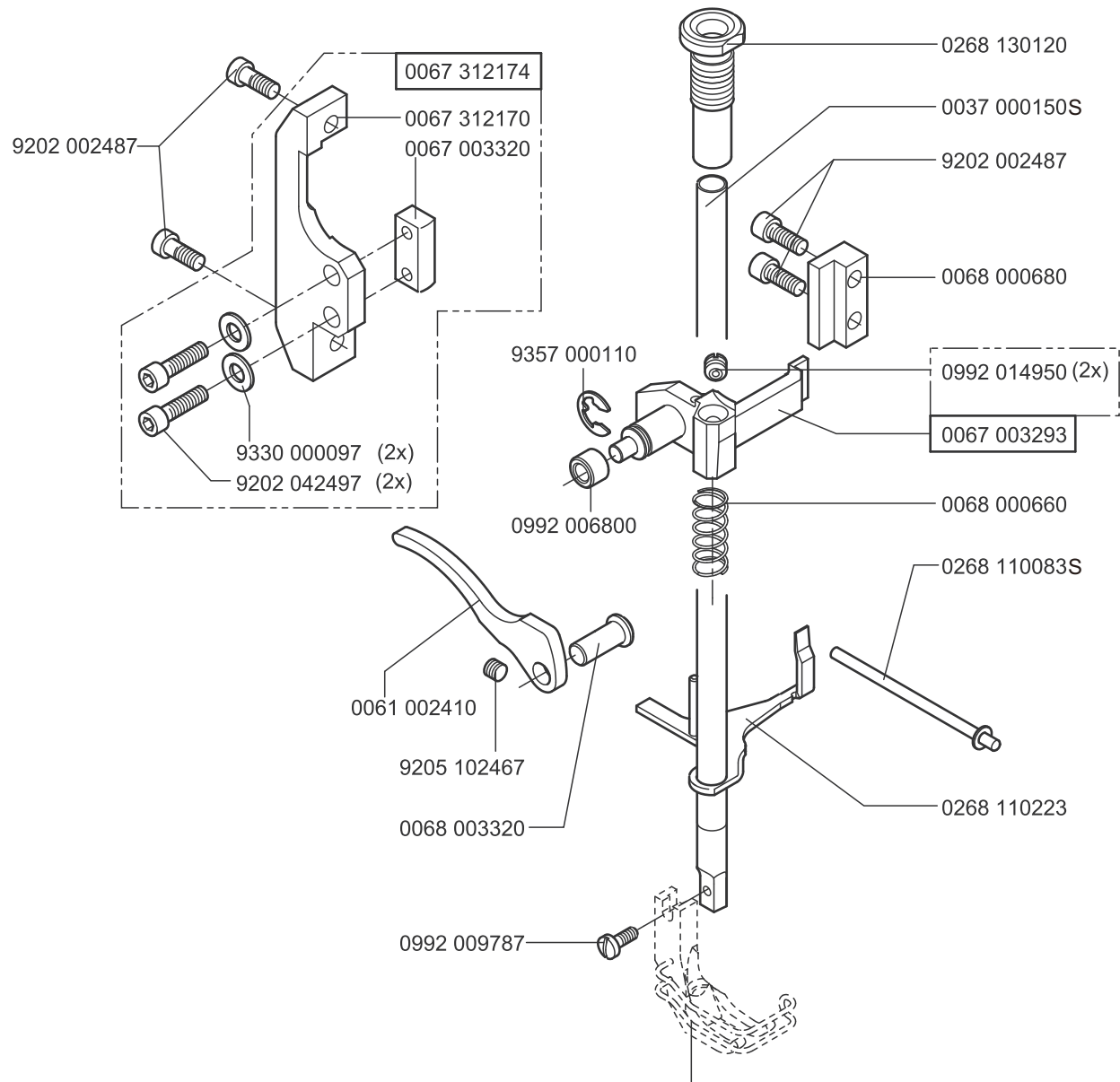

Part no. see sewing equipment
件号见缝纫附件

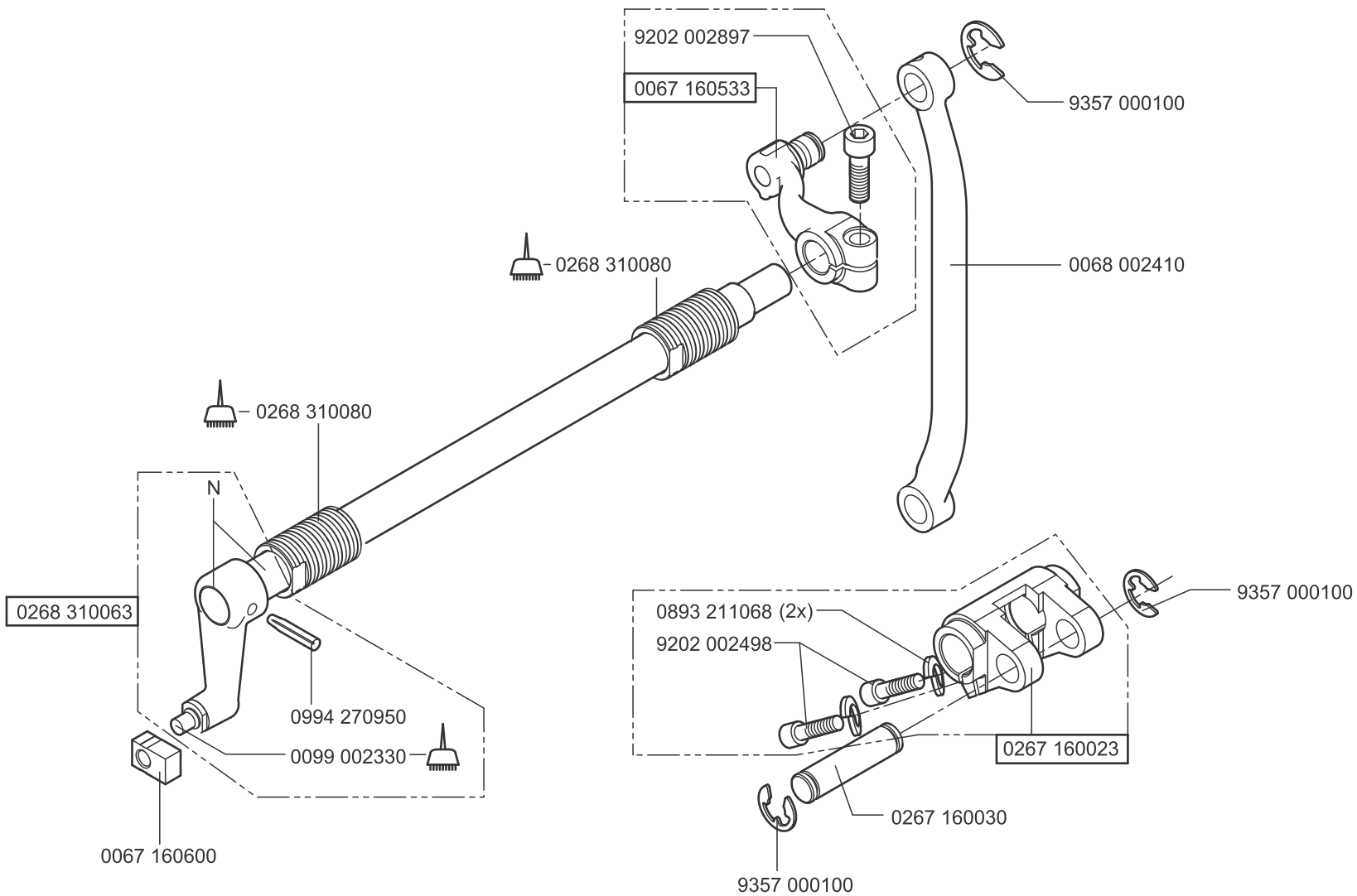

N- not available as separate part
不提供散件

-stick - 需用胶水

from 01.09.2008
从 2008 年 9 月 1 日开始

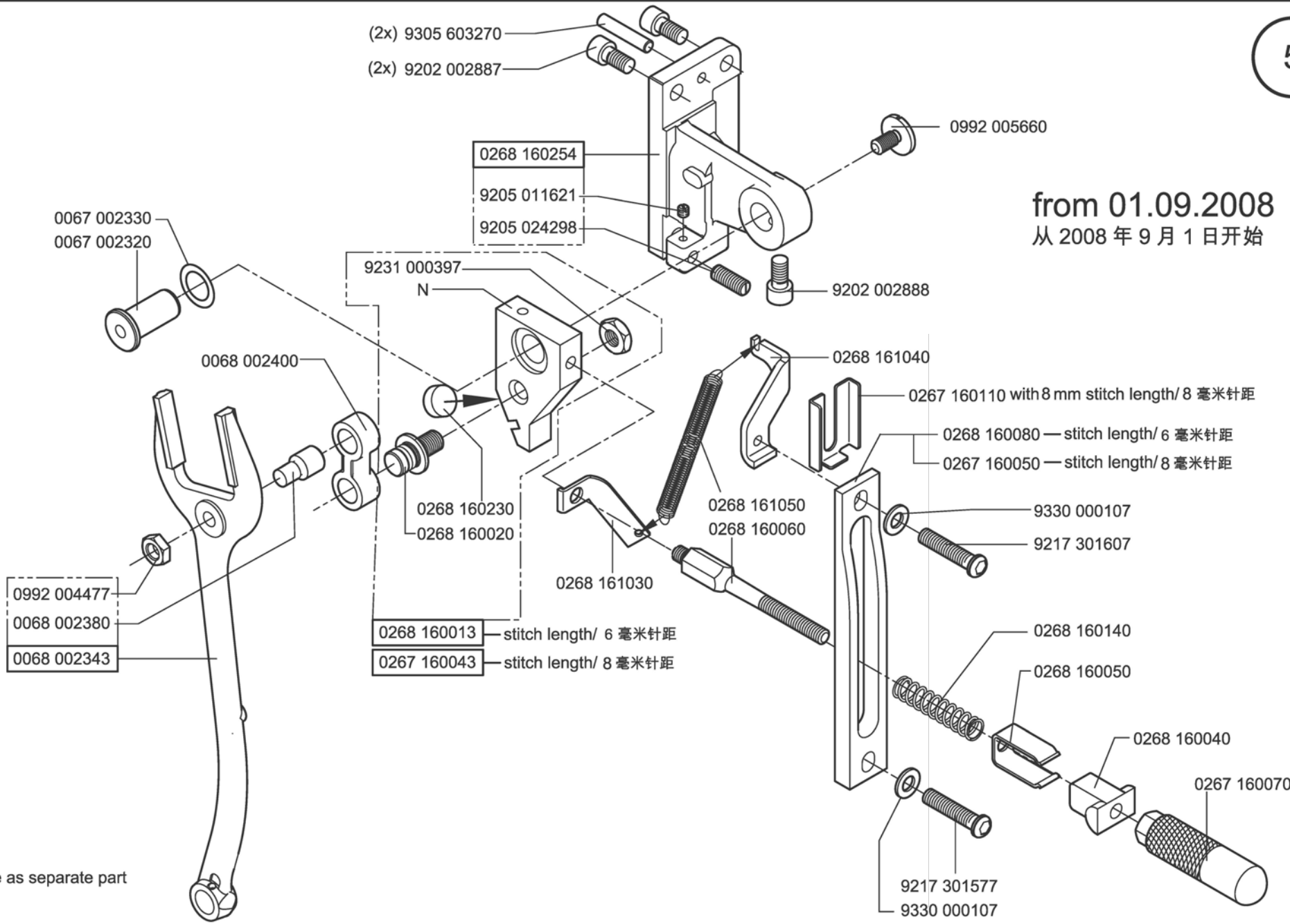

N- not available as separate part
不提供散件

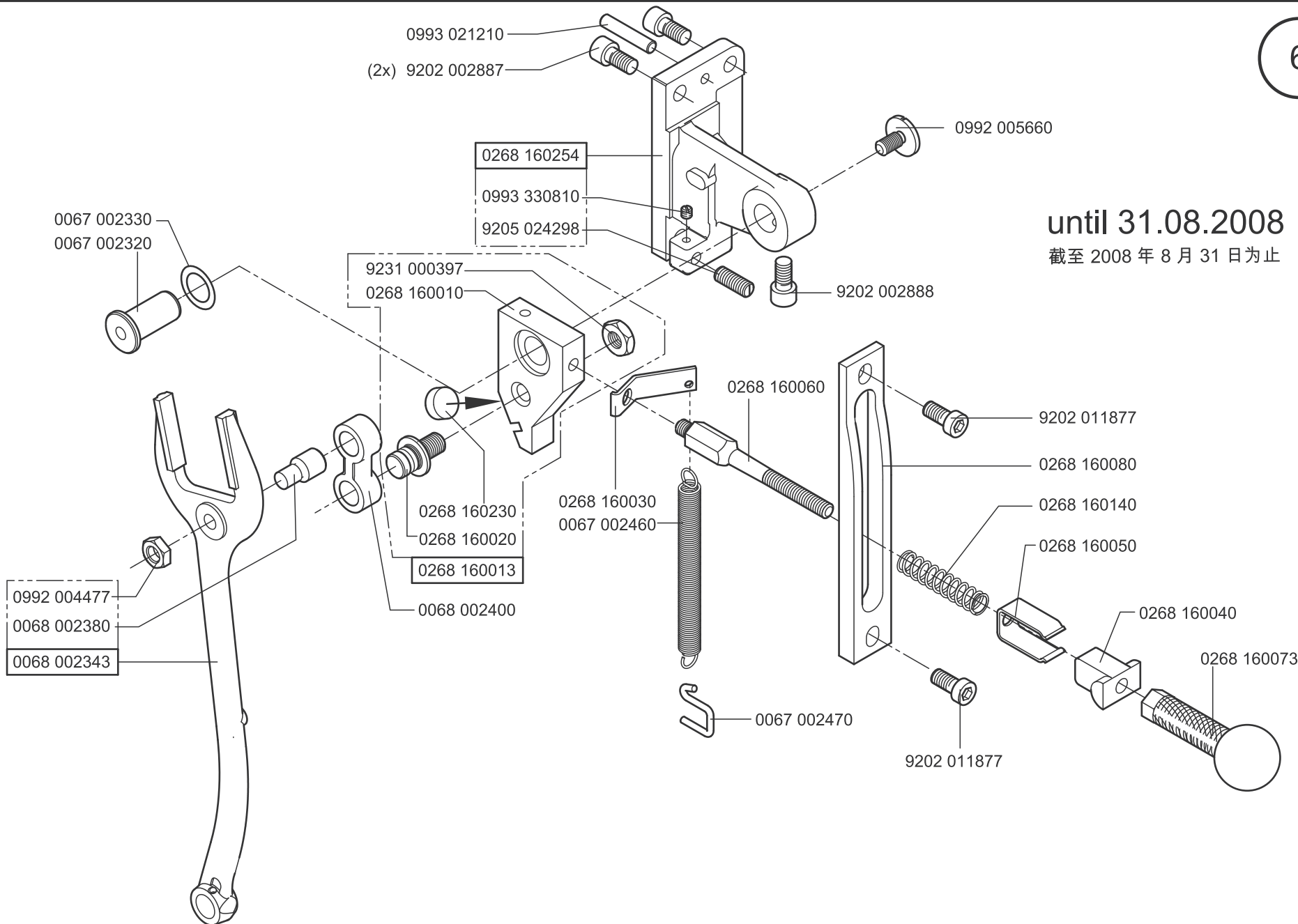

until 31.08.2008
截至 2008 年 8 月 31 日为止

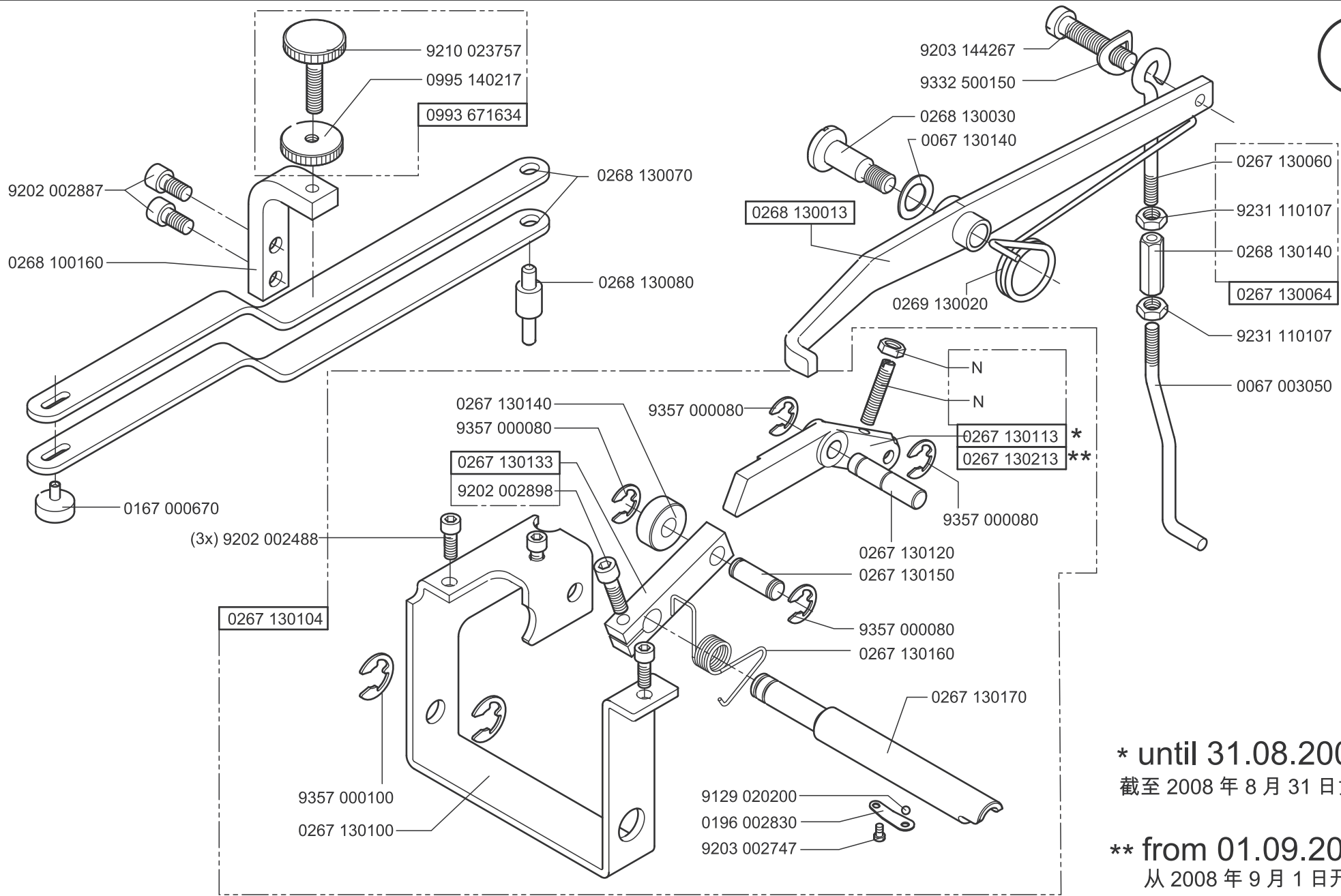

* until 31.08.2008
截至 2008 年 8 月 31 日为止

** from 01.09.2008
从 2008 年 9 月 1 日开始

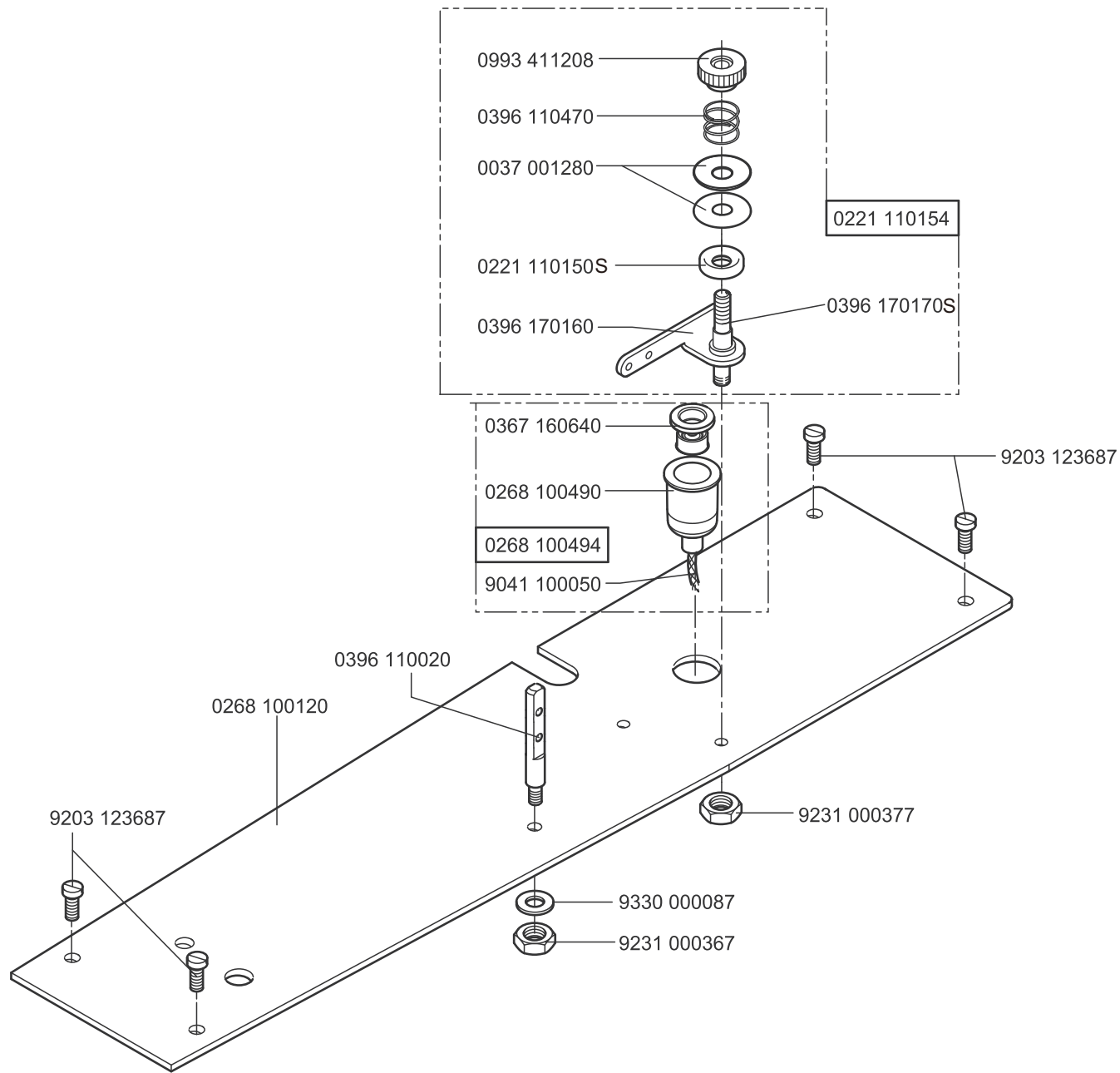

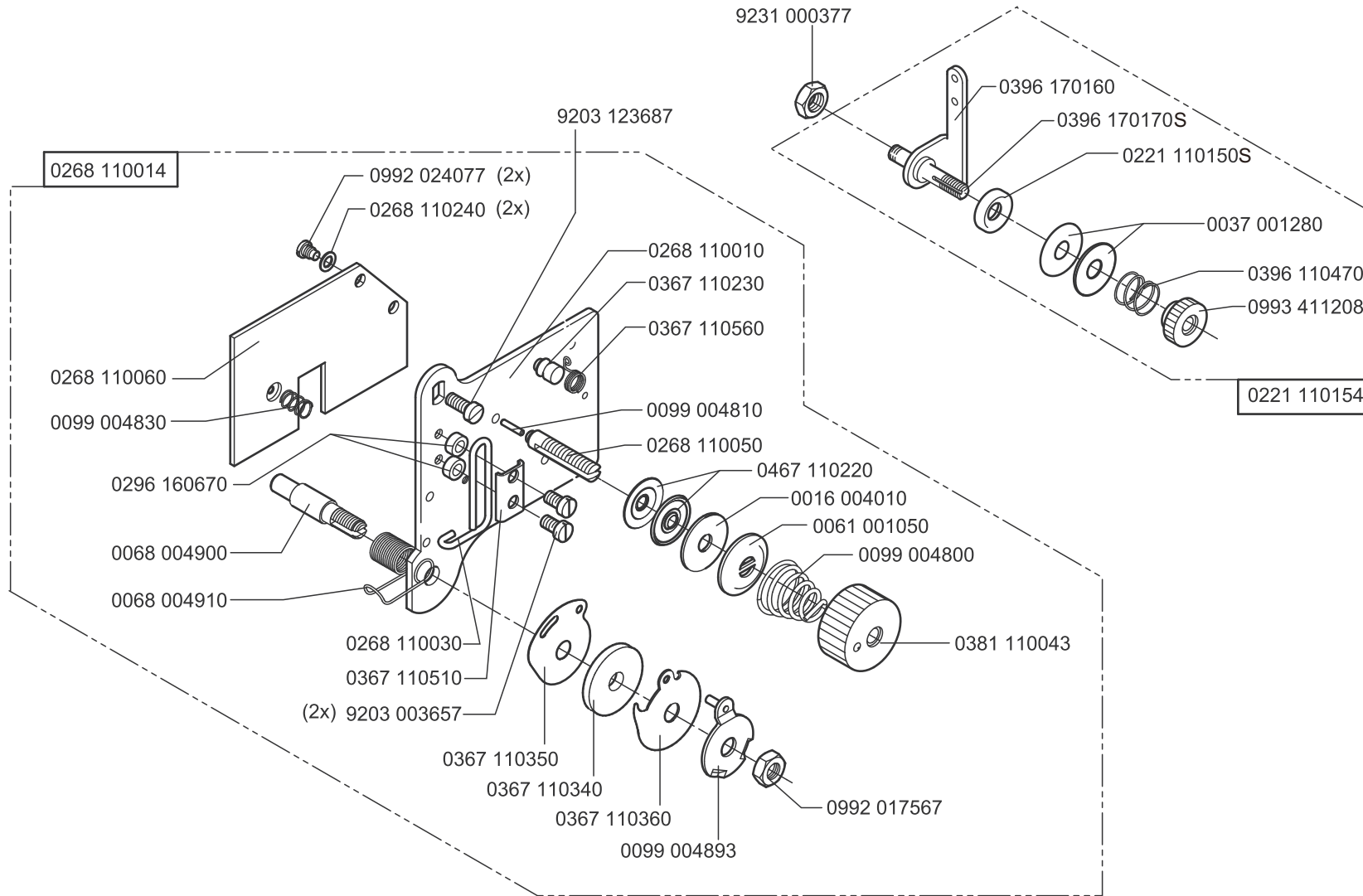

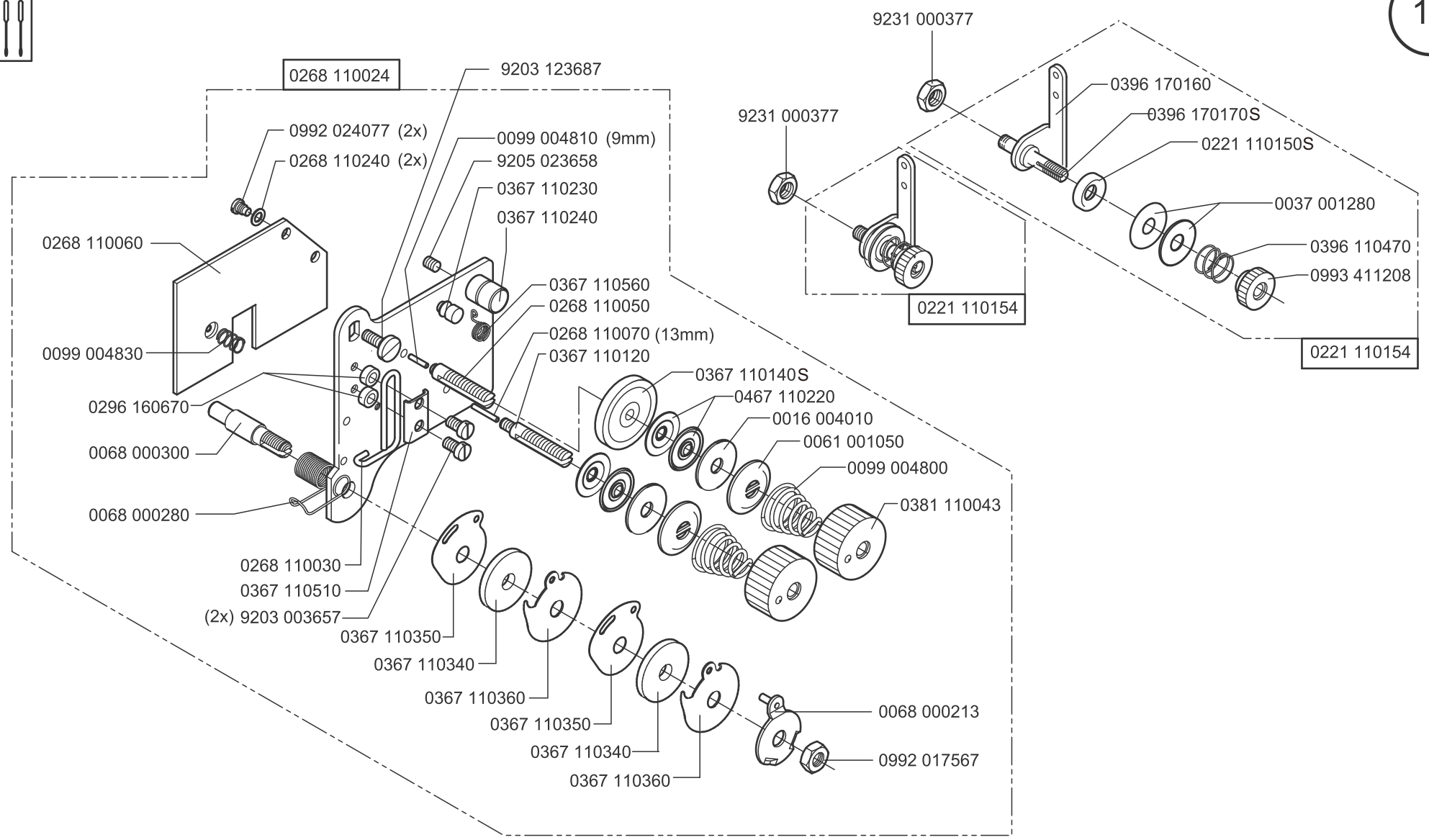

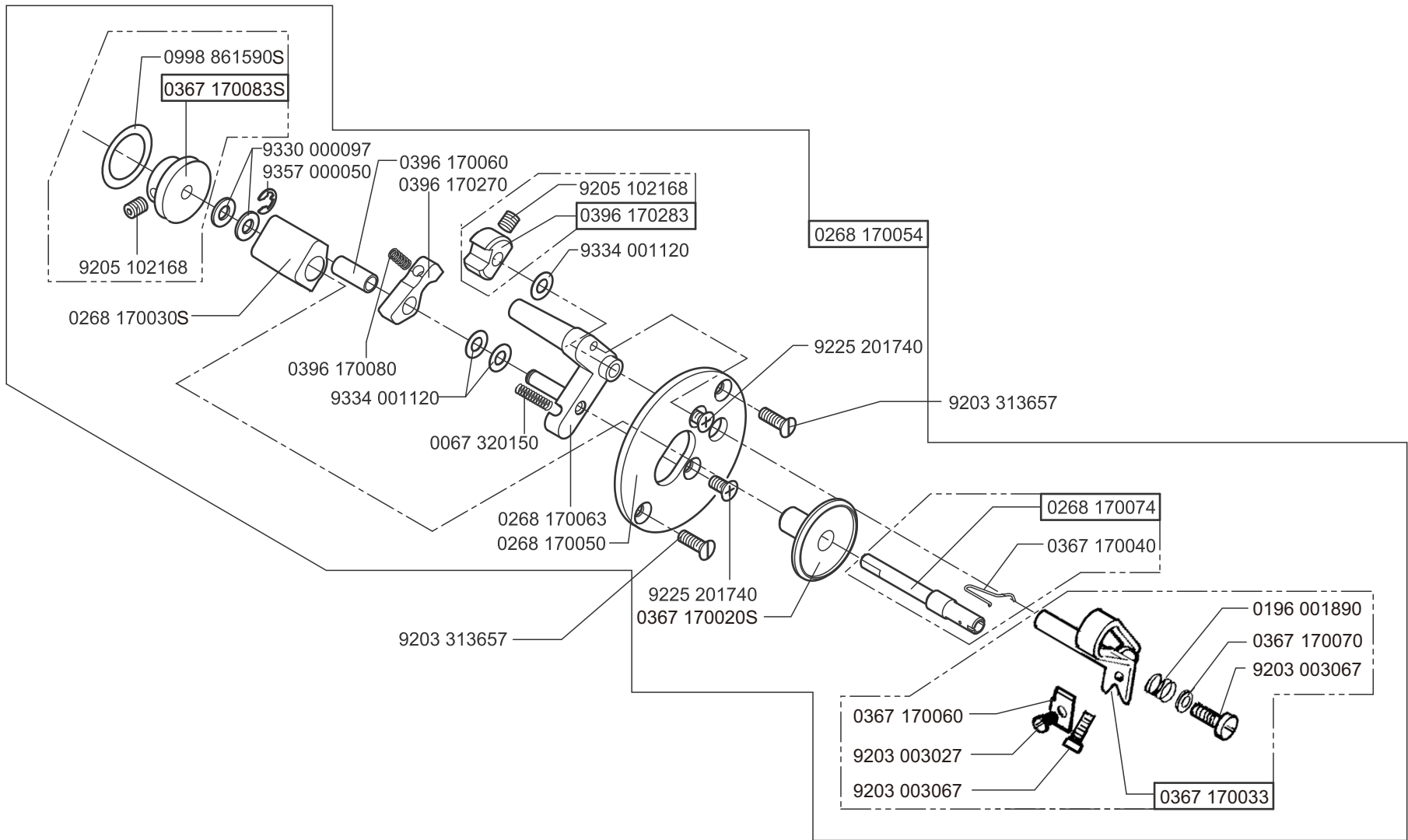

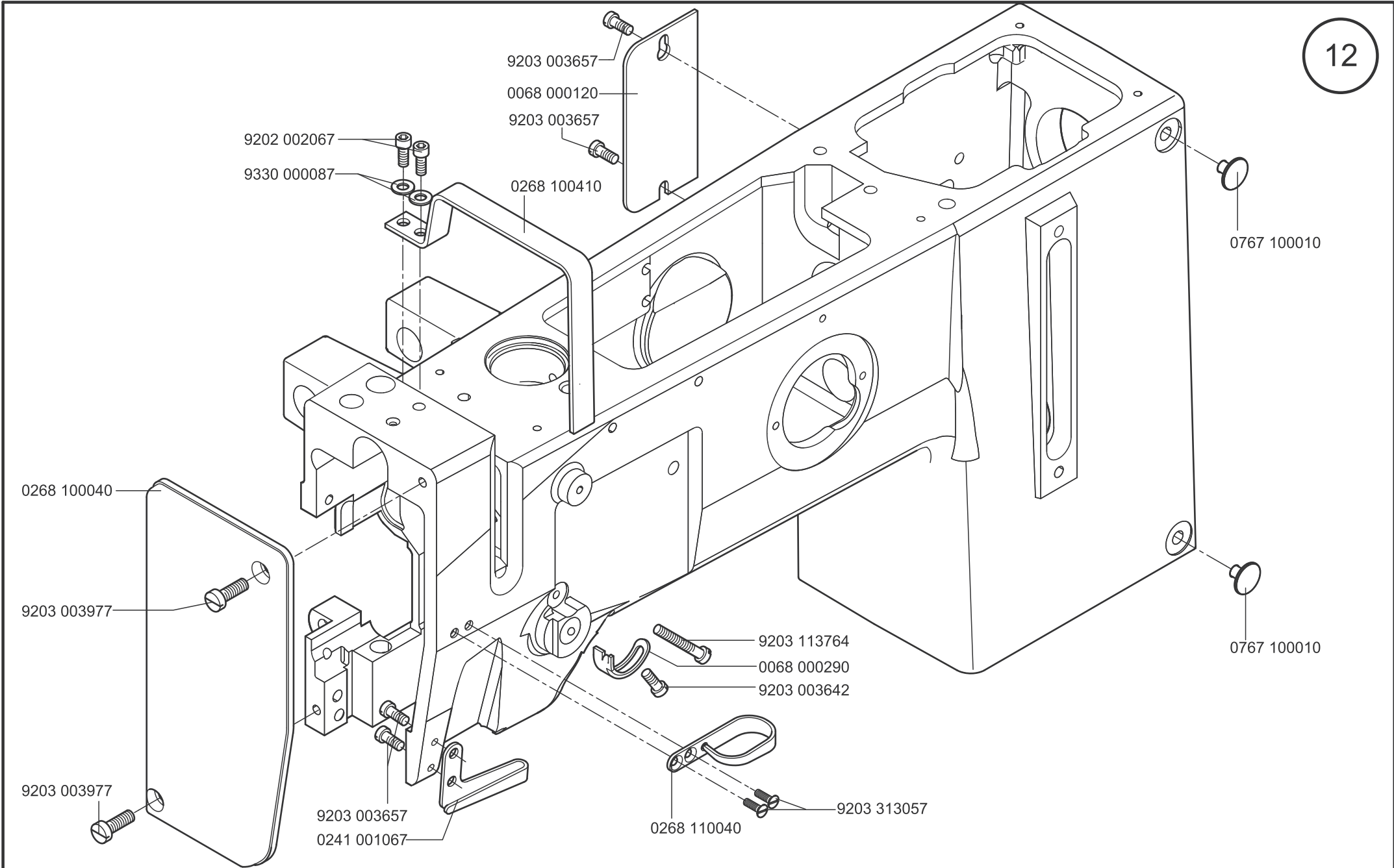

Scale / Scale 50%

CI. 267

Edition / 版本 04.2016

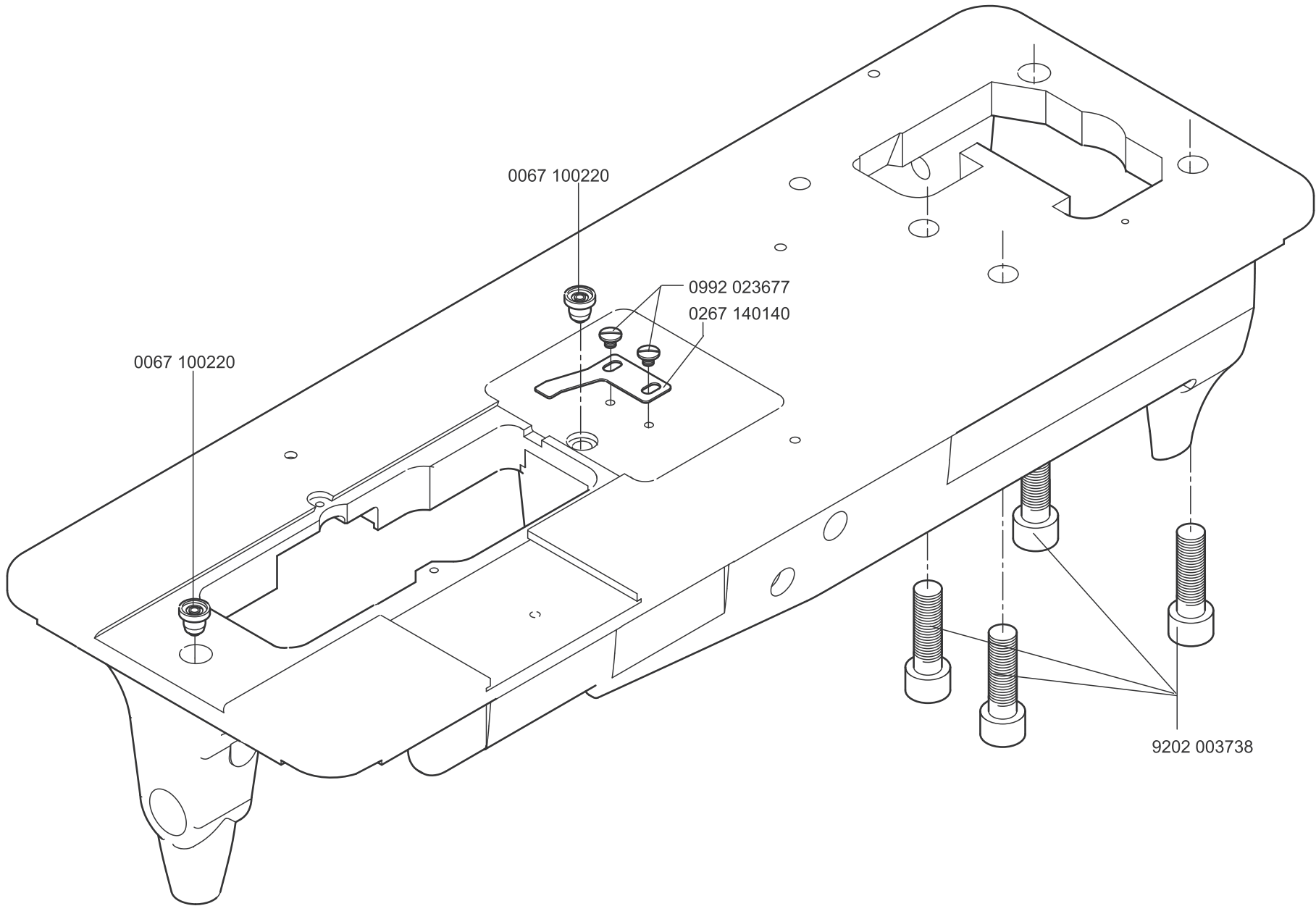

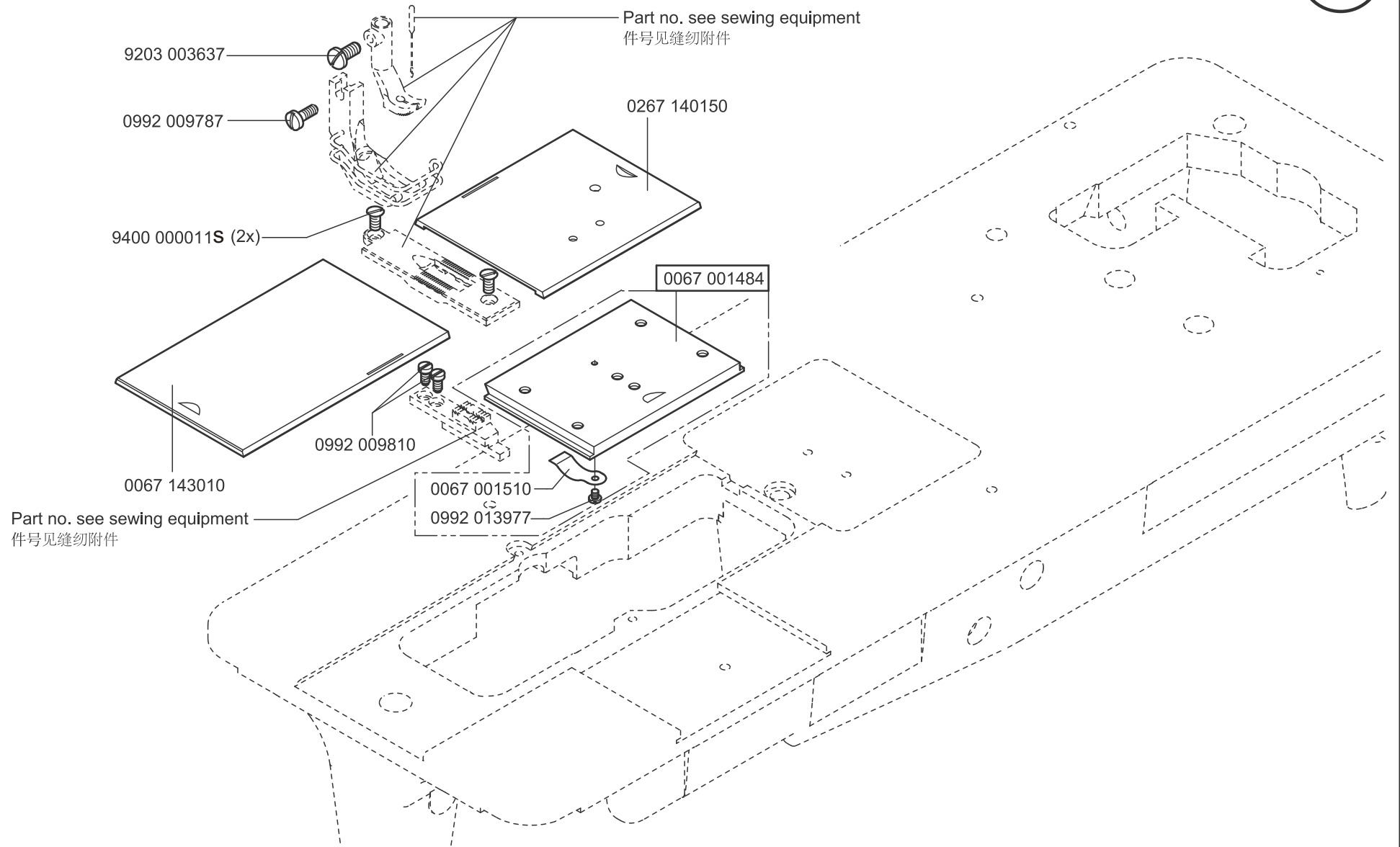



(1x)

0267 151884



0167 001700

0992 008986S

0008 001510

0067 150103

0167 150050

0167 001663S

0167 150040

0067 150060S

0068 151123S

0992 022790S

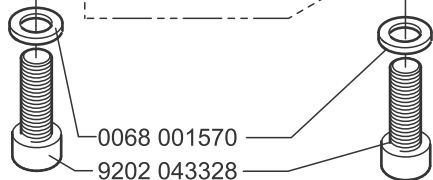

0068 001570

9202 043328



(1x)



(2x)

0167 001784

N

0992 019148

0992 019157

0167 150260

0167 001800

0992 016580

0167 001910

0267 151794

0992 006980S

0990 430911

N

0267 151860

0267 151850

0267 151840

0992 002660

0267 151884

N- not available as separate part
不提供散件



(1x)



(1x)

0267 151884

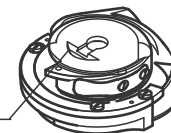

0167 001700

0992 008986S

0067 150103

0008 001510

0167 150050

0167 001663S

0167 150040

0067 150050S

0068 151123S

0992 022790S

0068 001570

9202 043328

15



(1x)

0267 151814

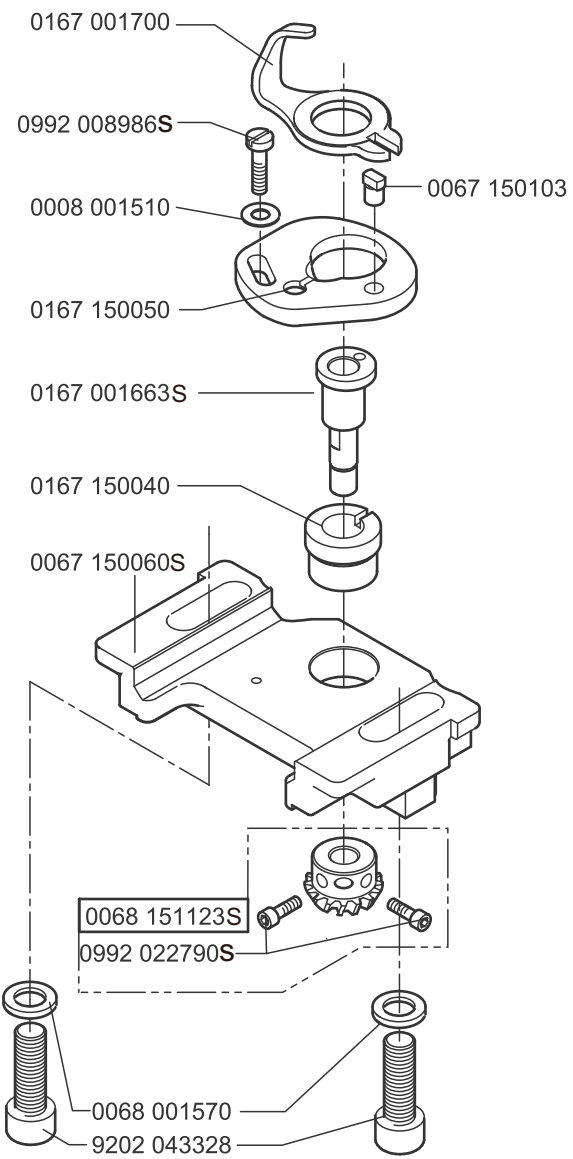

(1x)



(2x)

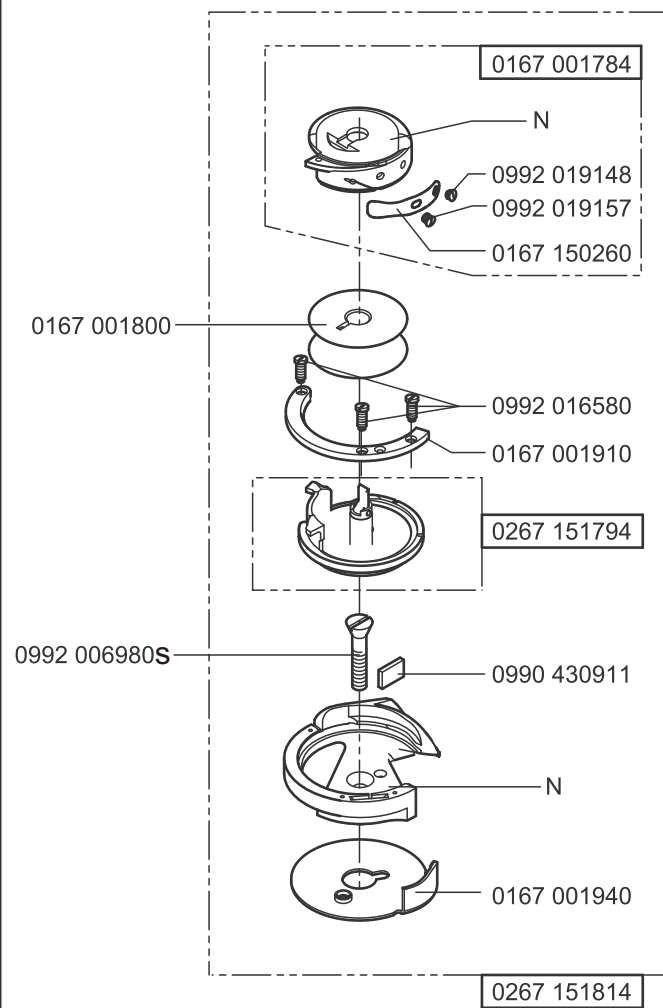

N- not available as separate part
不提供散件



(1x)



(1x)

16

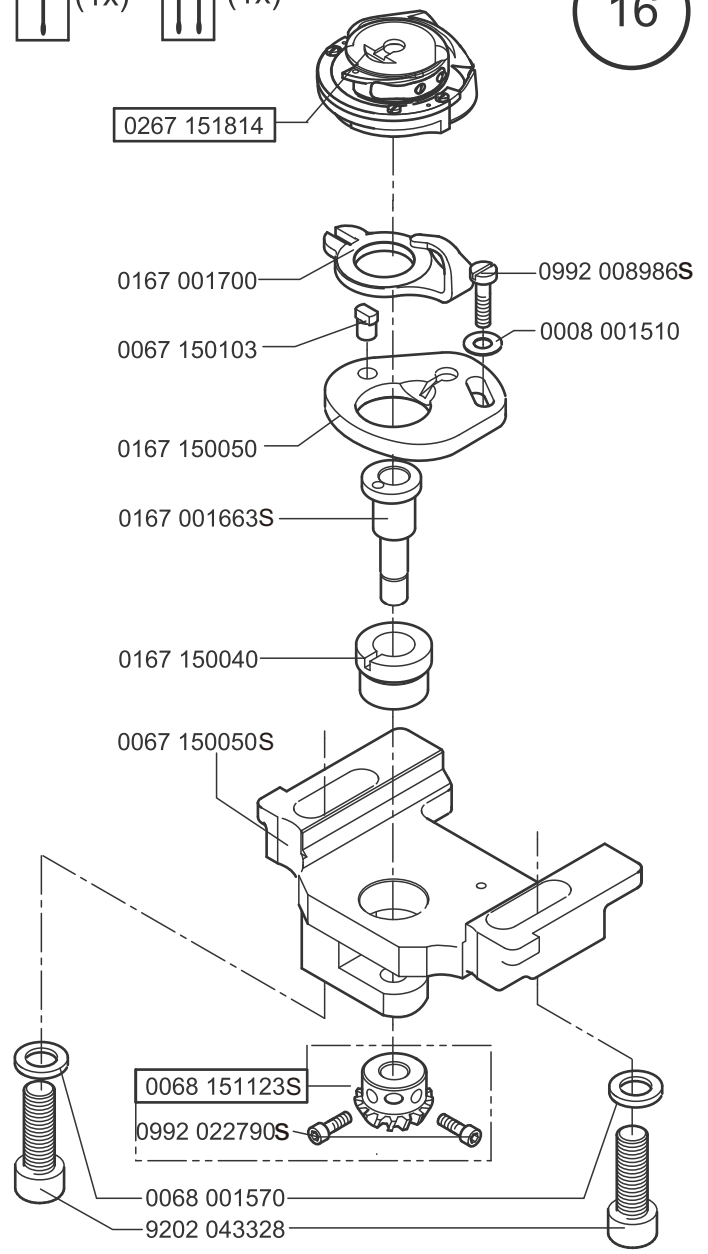

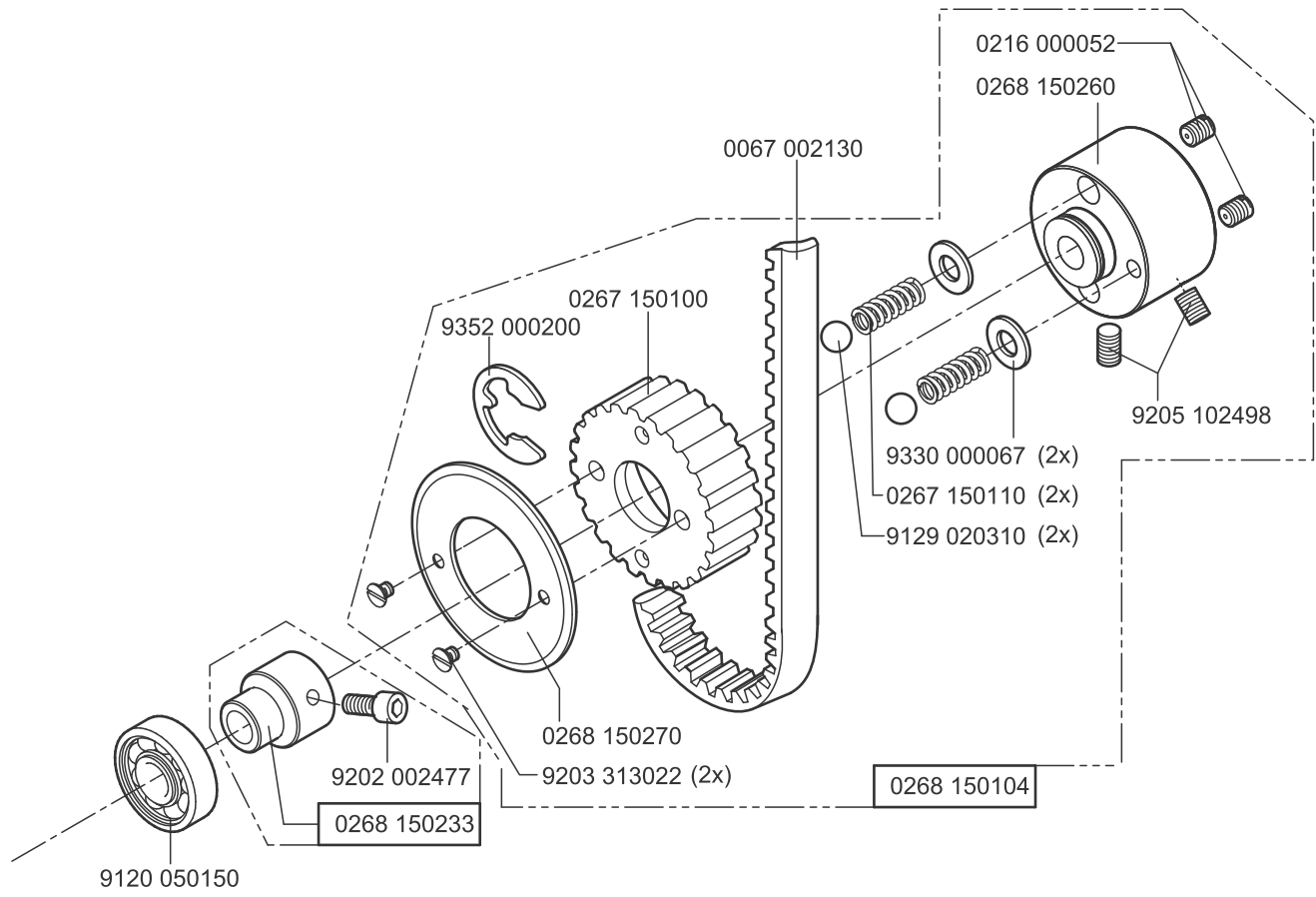

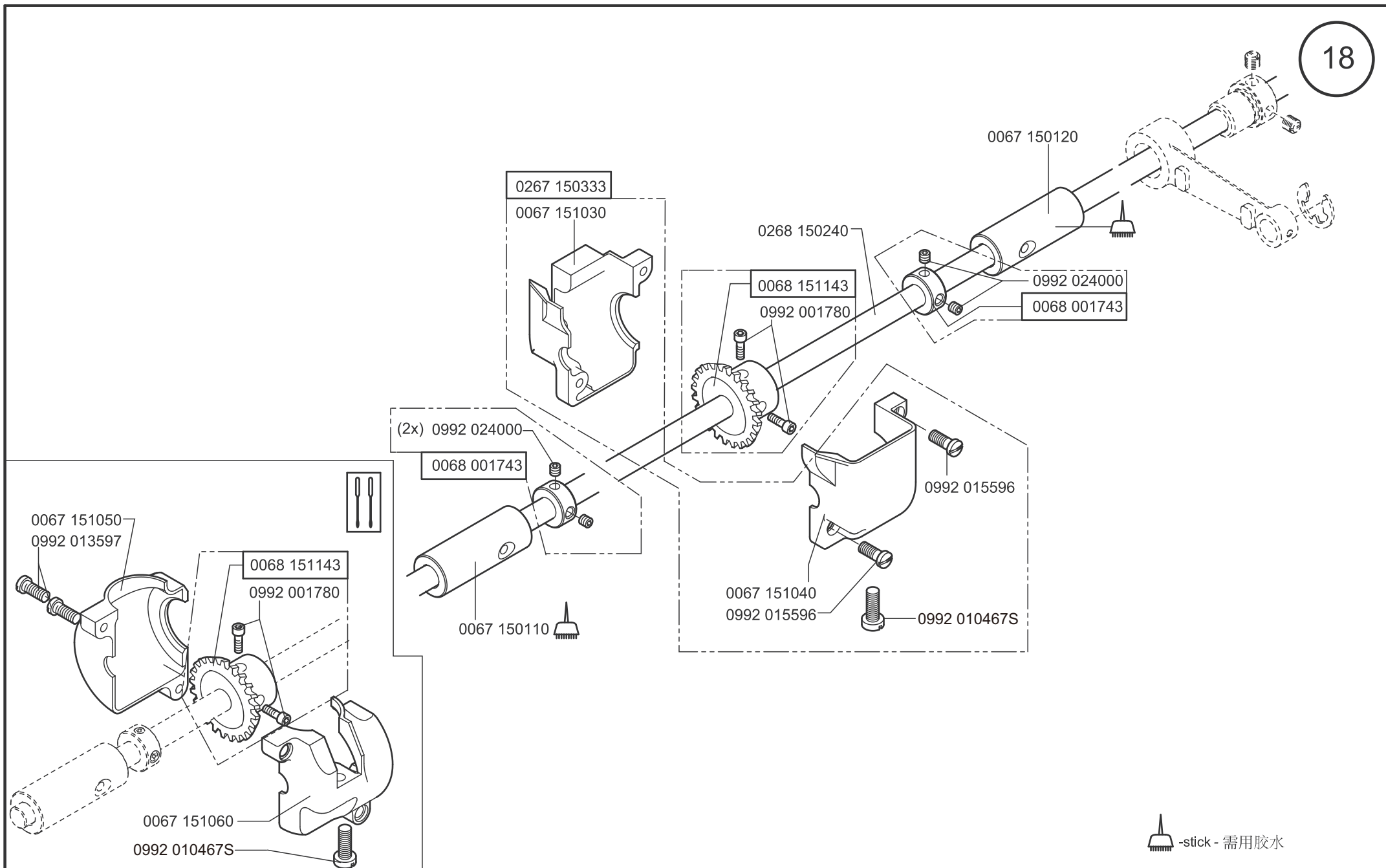

Scale / Scale 50%

CI. 267

 -stick - 需用胶水

Edition / 版本 04.2016

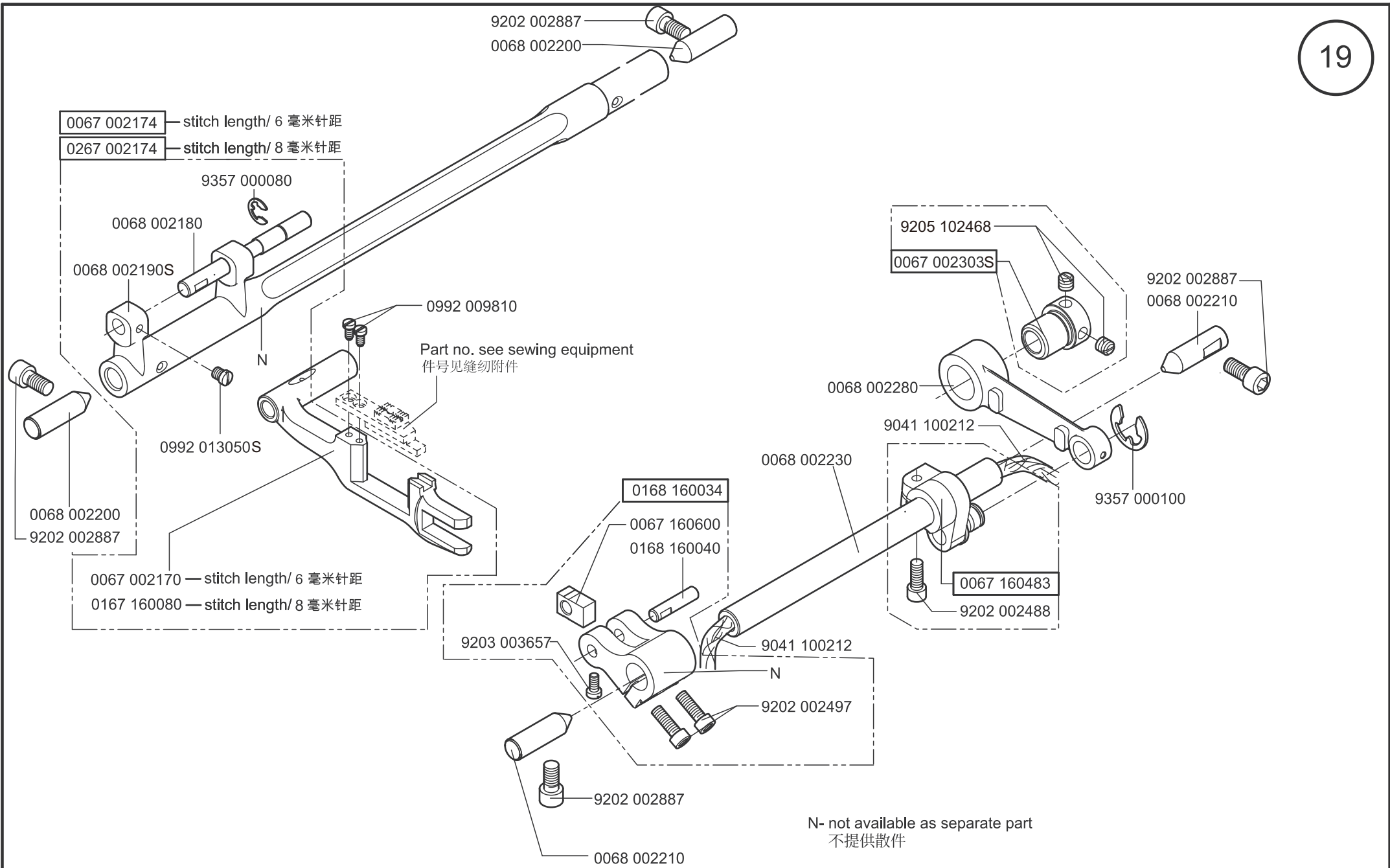

MG53 401134

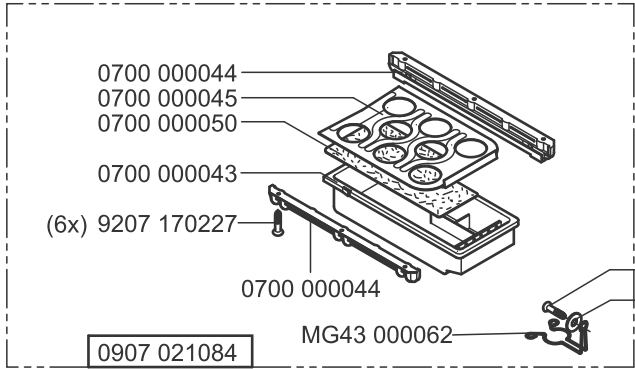
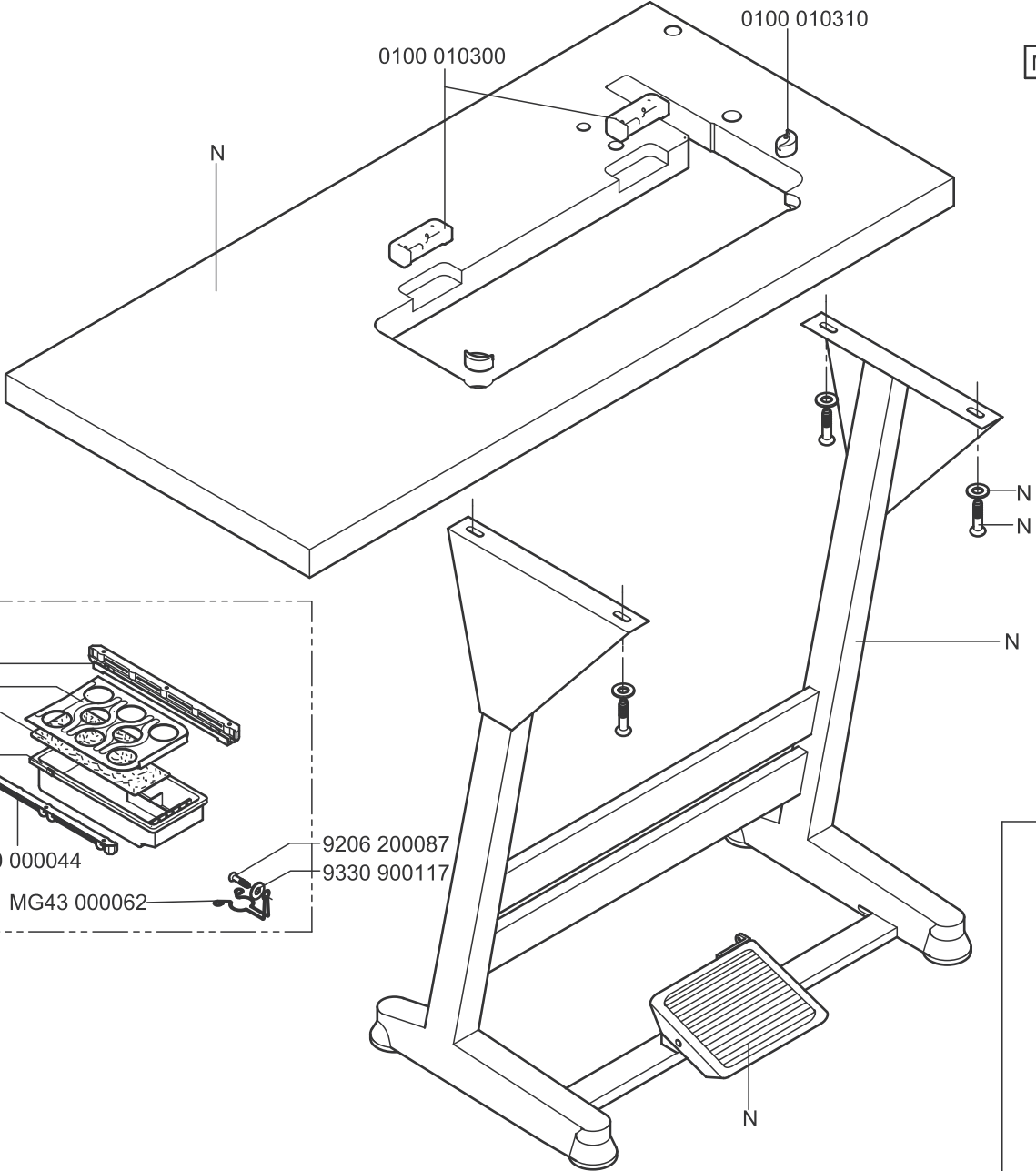

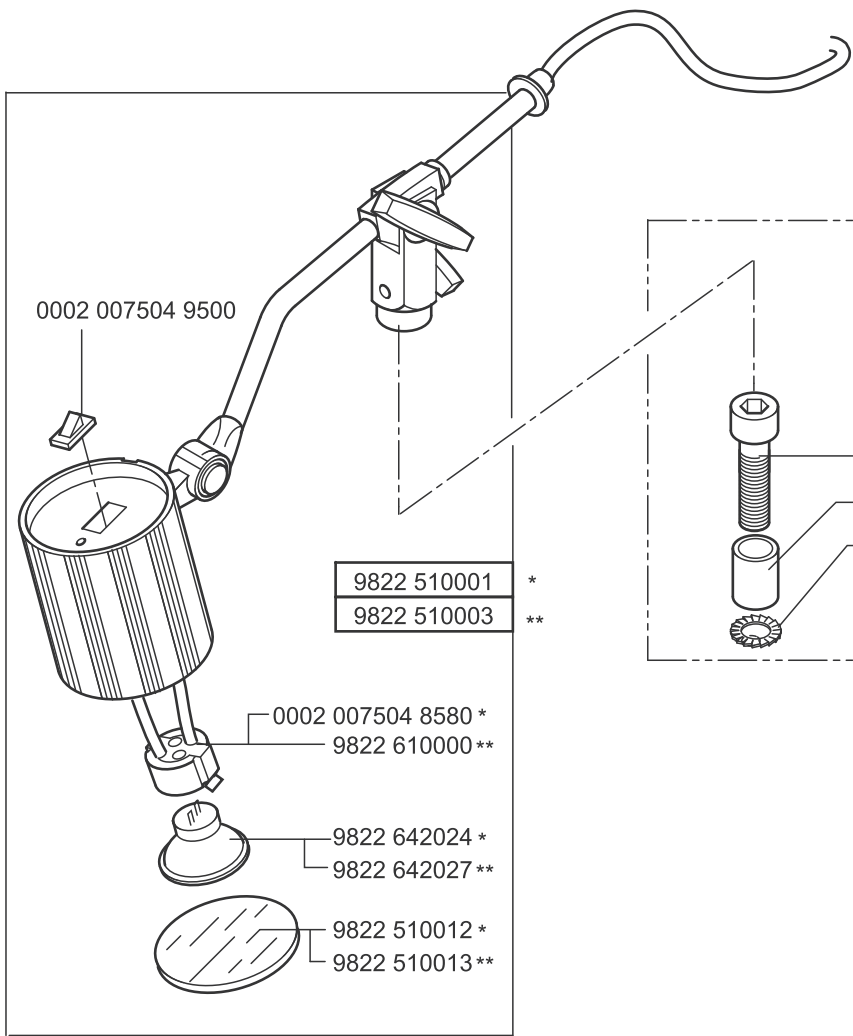

* until 05.2007 (HP20) 用到2007.05

** from 06.2007 (HIG 20 S)从2007.06开始

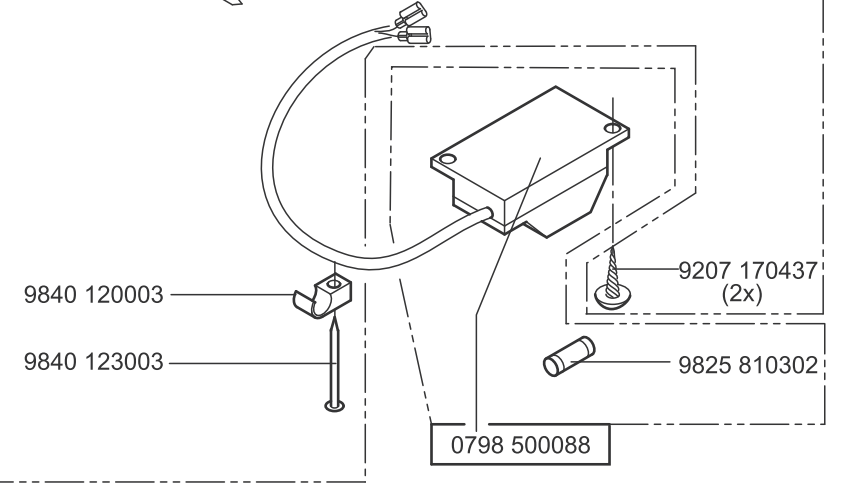
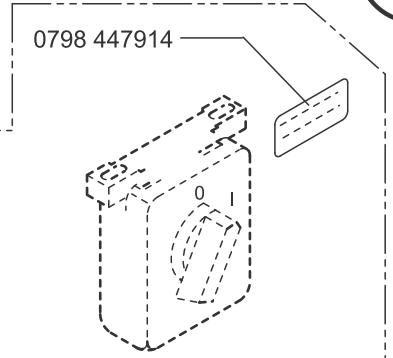
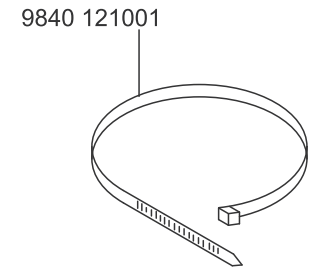
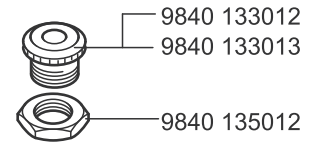
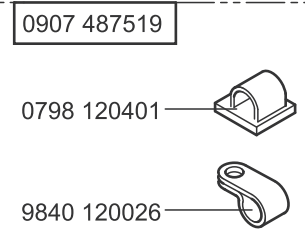
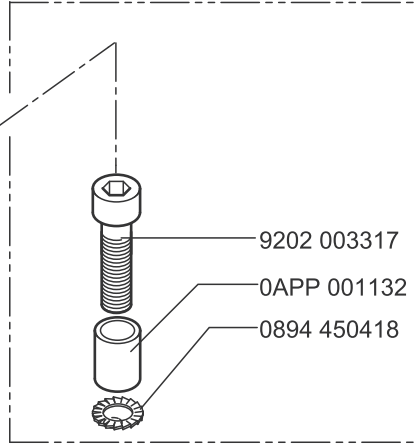

9800 110002 A FIR 1147.752.3 3x200-240/380-415V 50HZ

9889 026701 1

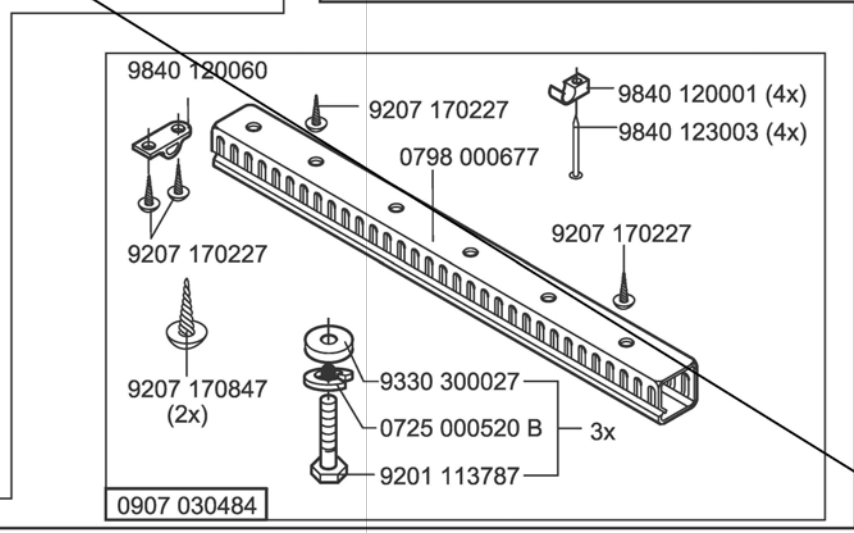
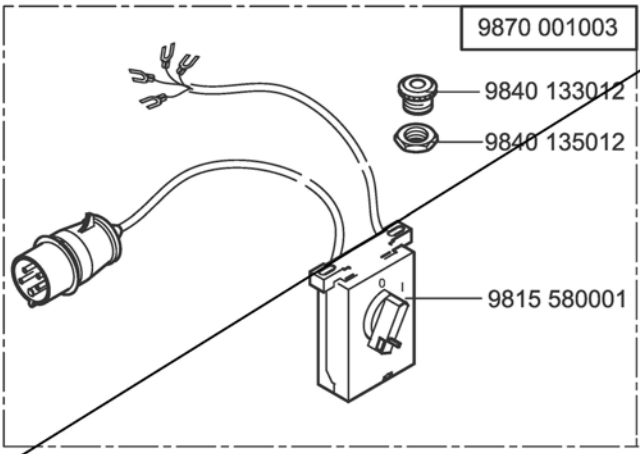
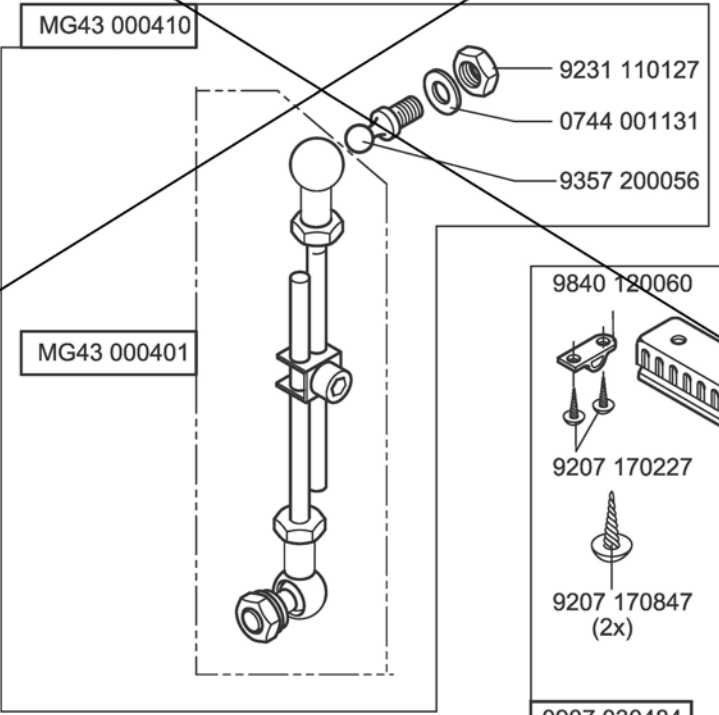
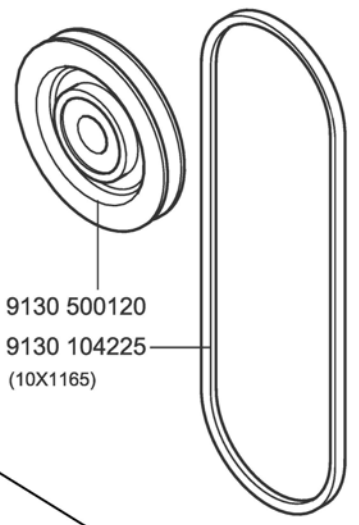
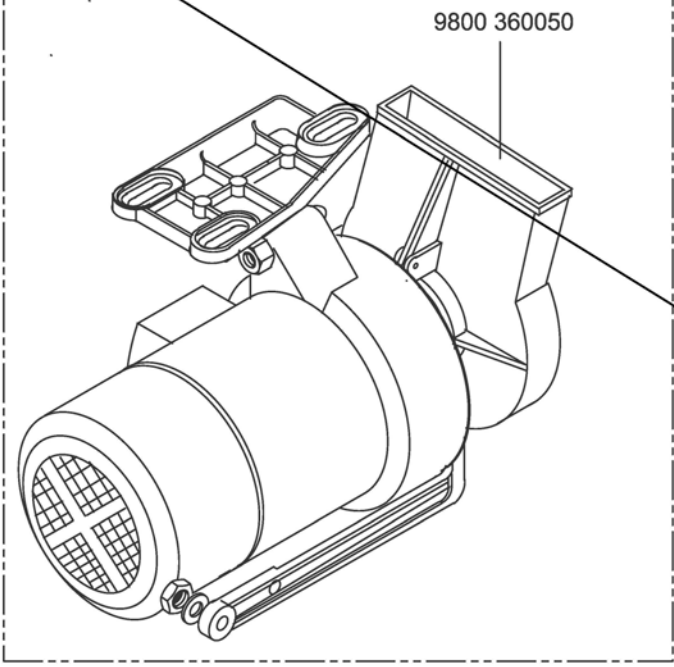

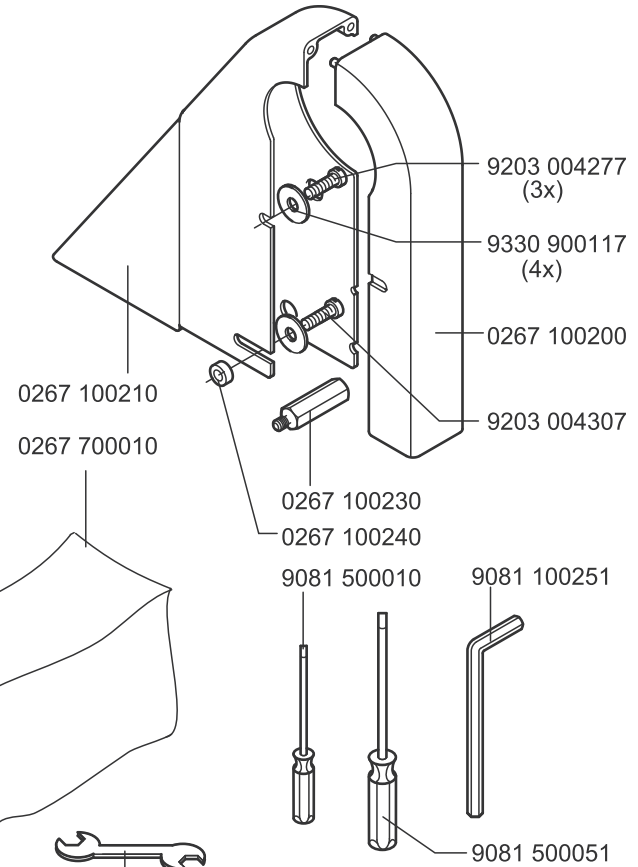
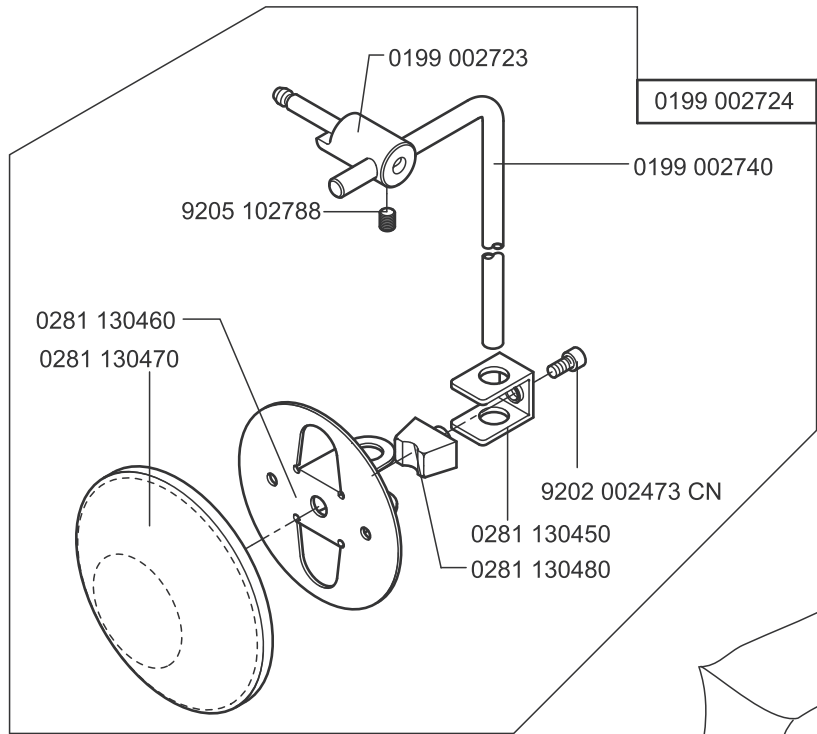

- 0267 700020
- (2x) 0100 010310
- (2x) 0100 010300
- (2x) 0196 003253
- 9205 102158 (M5x5) (2x)
- 9840 123003 (2x30) (16x)



0281 380114

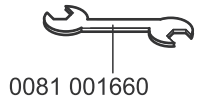
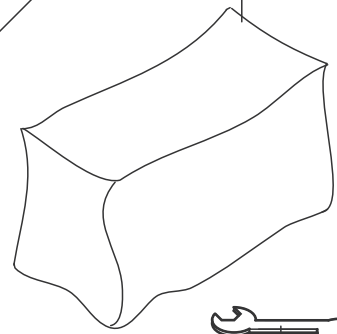

0081 001660

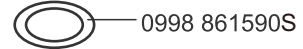

0998 861590S

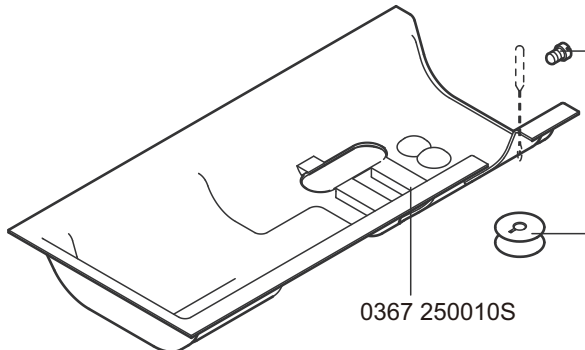

0281 700014

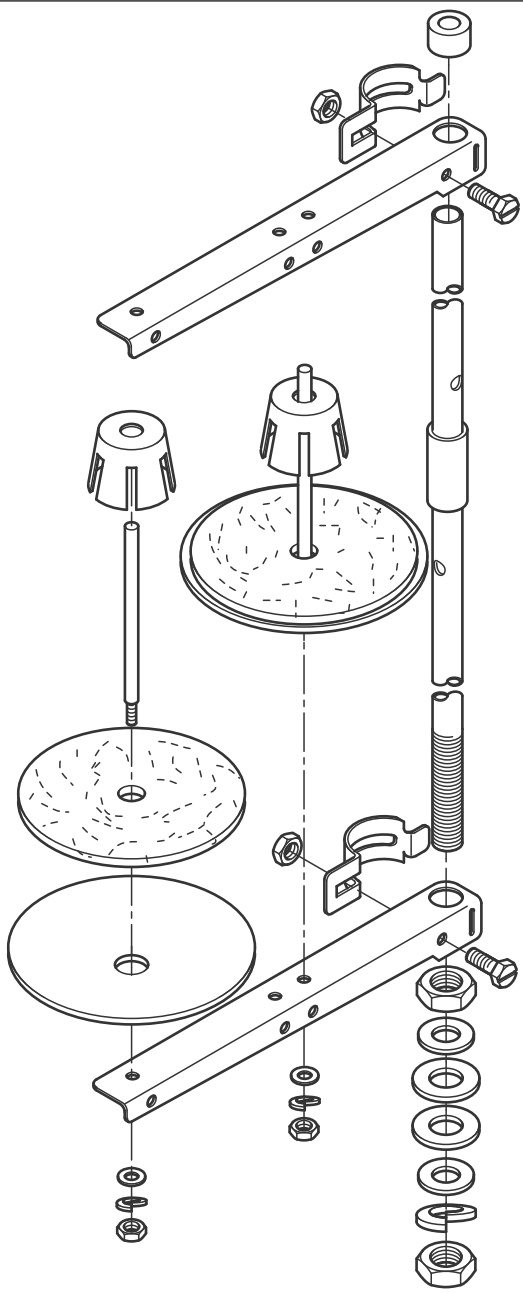
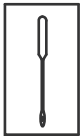

0791 267100

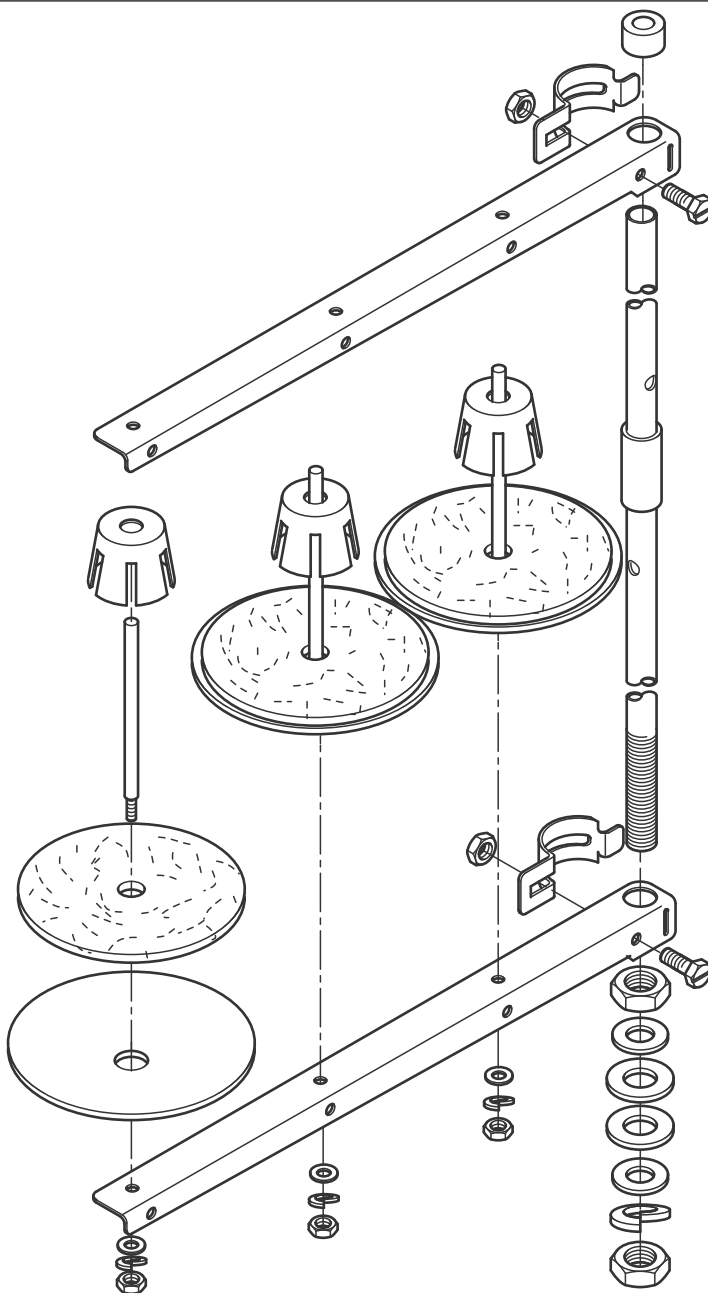

24

件号 /Part-No.	图表 /Table	件号 /Part-No.	图表 /Table	件号 /Part-No.	图表 /Table	件号 /Part-No.	图表 /Table				
0002	007504 8580	21	0067	150120	18	0068	002280	19	0196	002830	07
0002	007504 9500	21	0067	151030	18	0068	002343	05, 06	0196	003253	23
0008	001510	15, 16	0067	151040	18	0068	002380	05, 06	0199	002723	23
0016	004010	09, 10	0067	151050	18	0068	002400	05, 06	0199	002724	23
0037	000150S	03	0067	151060	18	0068	002410	04	0199	002740	23
0037	001280	08, 09, 10	0067	160013	01	0068	003320	03	0216	000052	17
0061	001050	09, 10	0067	160483	19	0068	004900	09	0221	110150S	08, 09, 10
0061	002410	03	0067	160533	04	0068	004910	09	0221	110154	08, 09, 10
0067	000180	02	0067	160600	04, 19	0068	008470	23			
0067	000423S	02	0067	312013	02	0068	151123S	15, 16	0223	000646	01
0067	001484	14	0067	312030	02	0068	151143	18	0241	001067	12
0067	001510	14	0067	312050	02	0069	312030	02	0267	002174	19
0067	002130	01, 17	0067	312070	02	0069	312040	02	0267	100200	23
0067	002170	19	0067	312170	03	0069	312053	02	0267	100210	23
0067	002174	19	0067	312174	03	0069	312070	02	0267	100230	23
0067	002303S	19	0067	312213	02	0081	001660	23	0267	100240	23
0067	002320	05, 06	0067	312214	02	0095	000110	02	0267	110030	02
0067	002330	05, 06	0067	312240	02	0098	101000	01	0267	120030	02
0067	002380	01	0067	312250	02	0099	002330	04	0267	130060	07
0067	002460	06	0067	320150	11	0099	004800	09, 10	0267	130064	07
0067	002470	06	0068	000120	12	0099	004810	09, 10	0267	130100	07
0067	003050	07	0068	000170	02	0099	004830	09, 10	0267	130104	07
0067	003123	02	0068	000213	10	0099	004893	09	0267	130113	07
0067	003133	02	0068	000280	10	0100	010300	20, 23	0267	130120	07
0067	003293	03	0068	000290	12	0100	010310	20, 23	0267	130133	07
0067	003320	03	0068	000300	10	0167	000670	07	0267	130140	07
0067	100014S	01	0068	000430	02	0167	001663S	15, 16	0267	130150	07
0067	100050	01	0068	000440	01	0167	001700	15, 16	0267	130160	07
0067	100220	13	0068	000470	02	0167	001784	15, 16	0267	130170	07
0067	100600	01	0068	000660	03	0167	001800	15, 16, 23	0267	130213	07
0067	100610	01	0068	000680	03	0167	001910	15, 16	0267	140140	13
0067	130140	07	0068	001570	15, 16	0167	001940	16	0267	140150	14
0067	143010	14	0068	001743	18	0167	150040	15, 16	0267	150100	17
0067	150033	01	0068	002180	19	0167	150050	15, 16	0267	150110	17
0067	150050S	15, 16	0068	002190S	19	0167	150260	15, 16	0267	150333	18
0067	150060S	15, 16	0068	002200	19	0167	160080	19	0267	151794	15, 16
0067	150103	15, 16	0068	002210	19	0168	160034	19	0267	151814	16
0067	150110	18	0068	002230	19	0168	160040	19	0267	151840	15

件号 /Part-No.	图表 /Table	件号 /Part-No.	图表 /Table	件号 /Part-No.	图表 /Table	件号 /Part-No.	图表 /Table
0267 151850	15	0268 130070	07	0281 130450	23	0798 000677	22
0267 151860	15	0268 130080	07	0281 130460	23	0798 120401	21
0267 151884	15	0268 130120	03	0281 130470	23	0798 447914	21
0267 160023	04	0268 130140	07	0281 130480	23	0798 500088	21
0267 160030	04	0268 150104	17	0281 380114	23	0893 211068	04
0267 160043	05	0268 150233	17	0281 700014	24	0894 450418	21
0267 160050	05	0268 150240	18	0291 000159	02	0907 021084	20
0267 160063	01	0268 150260	17	0296 160670	09, 10	0907 030484	22
0267 160070	05	0268 150270	17	0367 110120	10	0907 487519	21
0267 160110	05	0268 160010	06	0367 110140	10	0990 240181	01
0267 310013	02	0268 160013	05, 06	0367 110230	09, 10	0990 430911	15, 16
0267 700010	23	0268 160020	05, 06	0367 110240	10	0992 001780	18
0267 700020	23	0268 160030	06	0367 110340	09, 10	0992 002430	19
0268 100040	12	0268 160040	05, 06	0367 110350	09, 10	0992 002660	15
0268 100060	01	0268 160050	05, 06	0367 110360	09, 10	0268 003662	02
0268 100070	01	0268 160060	05, 06	0367 110510	09, 10	0992 004477	05, 06
0268 100120	08	0268 160073	06	0367 110560	09, 10	0992 005660	05, 06
0268 100134	01	0268 160080	05, 06	0367 160640	08	0992 006800	03
0268 100160	07	0268 160140	05, 06	0367 170040	11	0992 006980S	15, 16
0268 100193	01	0268 160230	05, 06	0367 170083S	11	0992 008986S	15, 16
0268 100393	01	0268 160254	05, 06	0381 110043	09, 10	0992 009787	03, 14
0268 100403	01	0268 161030	05	0396 110020	08	0992 009810	14, 19
0268 100410	12	0268 161040	05	0396 110470	08, 09, 10	0992 010467S	18
0268 100490	08	0268 161050	05	0396 170060	11	0992 012157	02
0268 100494	08	0268 170013	01	0396 170080	11	0992 013050S	19
0268 110010	09	0268 170030S	11	0396 170160	08, 09, 10	0992 013597	18
0268 110014	09	0268 170050	11	0396 170170S	08, 09, 10	0992 013977	14
0268 110024	10	0268 170054	11	0396 170270	11	0992 014950	03
0268 110030	09, 10	0268 170063	11	0396 170283	11	0992 015596	18
0268 110040	12	0268 170074	11	0467 110220	09, 10	0992 016580	15, 16
0268 110050	09, 10			0700 000043	20	0992 017567	09, 10
0268 110060	09, 10	0367 170033	11	0700 000044	20	0992 019148	15, 16
0268 110070	10	0367 170020S	11	0700 000045	20	0992 019157	15, 16
0268 110083S	03	0268 230014	02	0700 000050	20	0992 022790S	15, 16
0268 110223	03	0268 310013	01	0725 000520 B	22	0992 023677	13
0268 110240	09, 10	0268 310063	04	0744 001131	22	0992 023997S	01
0268 130013	07	0268 310080	04	0767 100010	12	0992 024000	18
0268 130030	07	0269 130020	07	0791 267100	24	9205 102468	23

件号 /Part-No.	图表 /Table	件号 /Part-No.	图表 /Table	件号 /Part-No.	图表 /Table	件号 /Part-No.	图表 /Table				
0992	024077	09, 10	9202	042497	03	9217	301607	05	9840	120026	21
0993	021210	06	9202	043328	15, 16	9225	201740	11	9840	120060	22
0993	330810	06	9203	002747	07	9231	000367	08	9840	121001	21
0993	411208	08, 09, 10	9203	003057	11	9231	000377	08, 09, 10	9840	123003	21, 23
0993	671634	07	9203	003637	14	9231	000397	05, 06	9840	123003 (4x)	22
0994	270950	04	9203	003642	12	9231	110107	07	9840	133012	21, 22
0994	271360	01				9231	110127	02, 22	9840	133013	21
0995	140217	07	9203	003657	09, 10, 12, 19	9305	603270	05	9840	135012	21, 22
0998	861590S	11, 23	9203	003977	12	9330	000067	17	9870	001003	22
0APP	001132	21	9203	004277	23	9330	000087	02, 08, 12	9889	026701 1	22
9041	100050	08	9203	004307	23	9330	000097	03, 11	MG43	000062	20
9041	100212	01, 02, 19	9203	113764	12	9330	000107	05	MG43	000401	22
9081	100251	23	9203	123687	08, 09, 10	9330	300027	22	MG43	000410	22
9081	500010	23	9203	144267	07	9330	900117	20, 23	MG53	401134	20
9081	500051	23	9203	312411	02	9332	500150	07			
9120	050150	17	9203	313022	17	9334	001120	11			
9120	080110	01	9203	313057	12	9352	000200	01, 17			
9129	016050	01	9203	313657	11	9352	000320	01			
9129	020200	07	9205	011621	05	9357	000050	11			
9129	020310	17	9205	023658	10	9357	000060	02			
9130	104225	22	9205	023920	02	9357	000080	02, 07, 19			
9130	500120	22	9205	024298	05, 06	9357	000100	02, 04, 07, 19			
9201	113787	22	9205	101528	02	9357	000110	03			
9202	002067	12	9205	102158	23	9357	200056	22			
9202	002097	02	9205	102168	11	9400	000011S	14			
9202	002473 CN	23	9205	102467	02, 03	9800	110002 A	22			
9202	002477	17	9205	102478	01, 02	9800	360050	22			
9202	002487	03	9205	102488	01	9815	580001	22			
9202	002488	07, 19	9205	102498	17	9822	510001	21			
9202	002497	19	9205	102788	23	9822	510003	21			
9202	002498	04	9205	122478	01	9822	510012	21			
9202	002887	05, 06, 07, 19	9205	122498	01	9822	510013	21			
9202	002888	05, 06	9206	200087	20	9822	610000	21			
9202	002897	02, 04	9207	170227	20, 22	9822	642024	21			
9202	002898	07	9207	170437	21	9822	642027	21			
9202	003317	21	9207	170847	22	9825	810302	21			
9202	003738	13	9210	023757	07	9840	120001 (4x)	22			
9202	011877	06	9217	301577	05	9840	120003	21			

Fastening parts for sewing equipments

缝纫附件紧固件

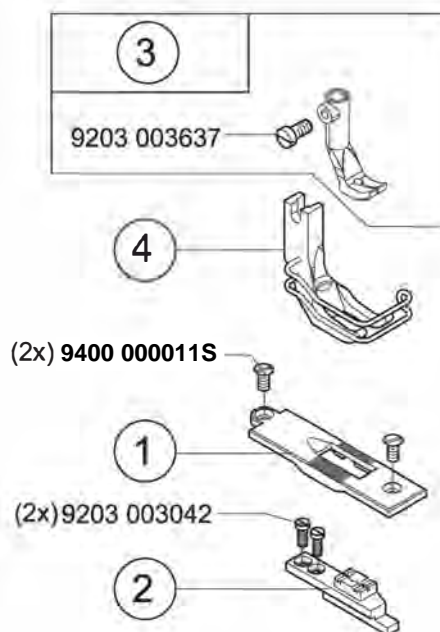
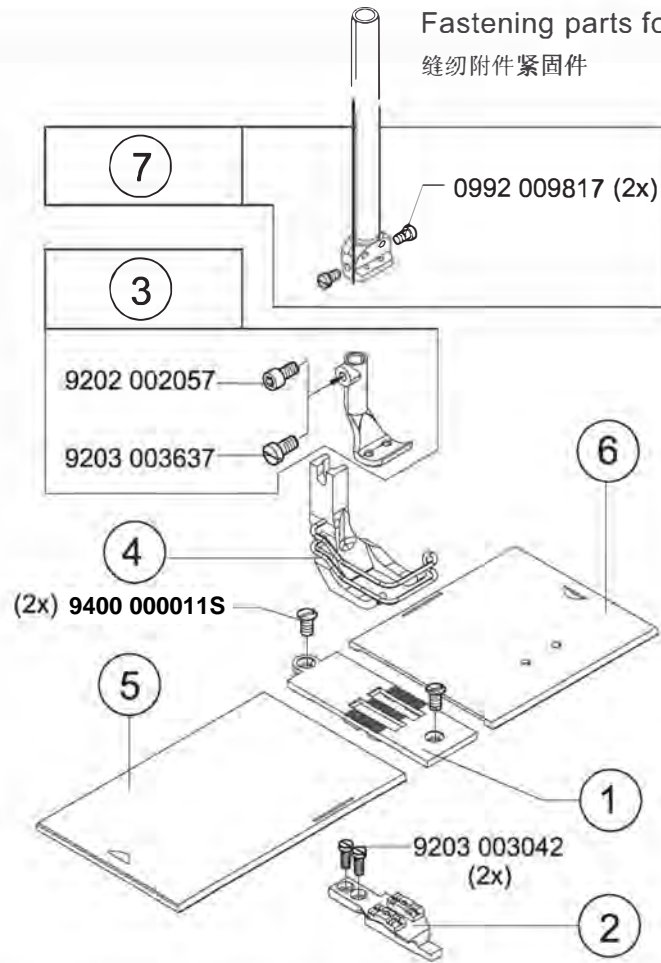

E2

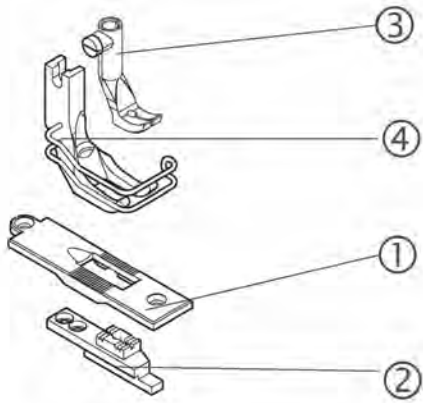

E8/6

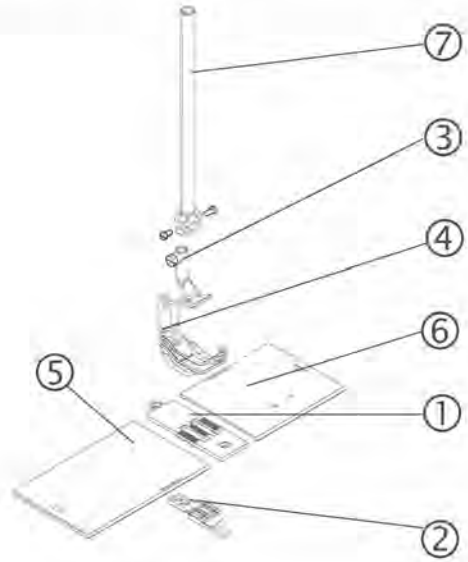

E8/8

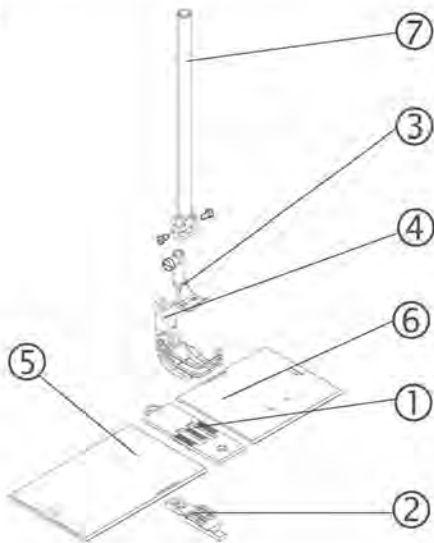

E8/12

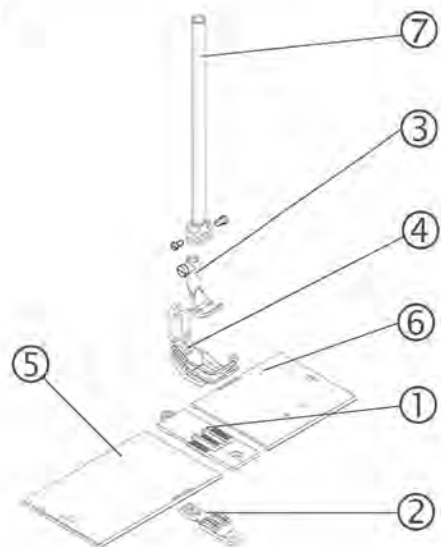

E8/14

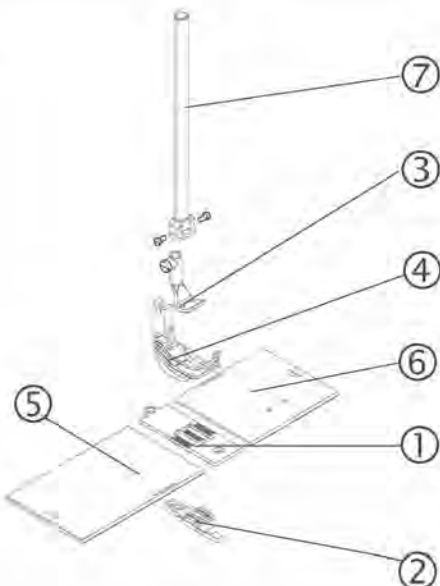

E34

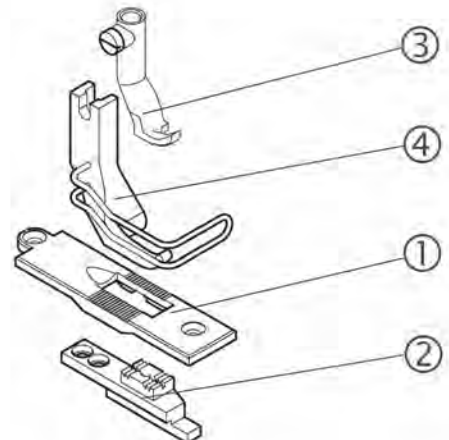

E49

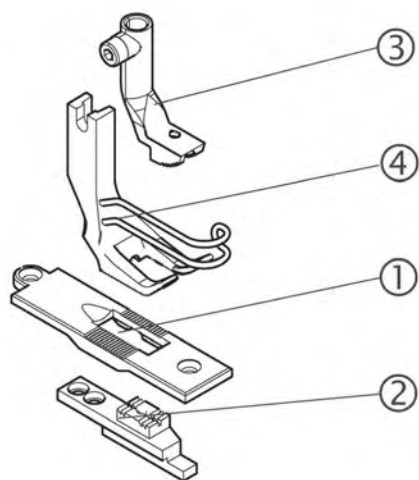

E50

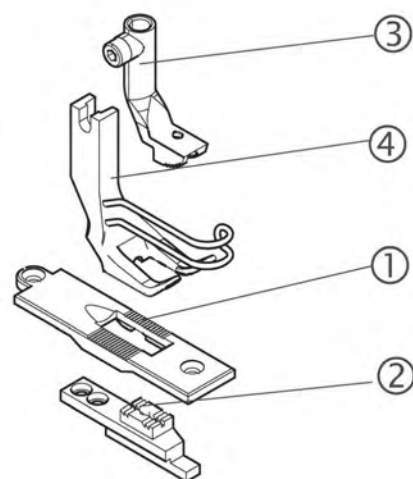

E-No. Fig.No.	For Subclass / 适用机型 Use/ 用途	Needle holder 针夹		Throat plate ① 针板			Main feed dog 主送料牙 ②			Presser foot 压脚		Hook 旋梭								
		Needle distance mm	Needle holder	Needle holder, left	Needle holder, right	Stitch hole size mm	Throat plate	Slide, left	Slide, right	Stitch hole size mm	Serrated mm	Serrated, oblique mm	Cross toothed mm	Roof-shaped mm	Feed foot ③	Presser foot ④	Foot, articulated, with lever	Foot, articulated	Needle guard	Needle system
E2	-373 Sewing equipment for general stitching operations in medium weight material in the production of upholstery, tarpaulins and leather articles. Needle size Nm 110-140. Stitch length max. 6 mm 适用于缝制中厚料沙发、帐篷和皮革制品的缝纫附件。 针规格: Nm110-140 最大针距长度: 6mm					ø 2.5	0167 200150			0167 210140				0267 220013	0267 220023S					134-35 / 120-130
E34	-373 Sewing equipment for edge seams on the right in medium weight material in the production of upholstery, bags and leather articles. Seam margin 1 mm. Needle size Nm 110-140. Stitch length max. 6 mm 适用于缝制中厚料沙发、箱包和皮革制品时右侧边缝的缝纫附件。 针规格: Nm110-140 最大针距长度: 6mm					ø 2.5	0167 200150			0167 210140				0067 220713	0067 220783					134-35 / 120-130
E49	-373 Sewing equipment for welting operations in medium weight material (coarsely woven fabrics) in the production of upholstery. Welt groove 5 mm to the left of the needle in feeding foot and double toe jumping foot. Needle size Nm 110-140. Stitch length max. 6 mm 适用于缝制中厚料沙发、(粗织纤维) 嵌缝的缝制设备, 在送料压脚和大压脚中嵌条槽距针左侧距离为 5mm。 针规格: Nm110-140 最大针距长度: 6mm					ø 2.5	0167 200150			0167 210140				0167 220603	0167 220613					134-35 / 120-130
E50	-373 Same as E49, but welt groove 6 mm. 同 E49, 但嵌条槽距针左侧距离 6mm。					ø 2.5	0167 200150			0167 210140				0167 220603	0167 220623					134-35 / 120-130

Contact:

Dürkopp Adler GmbH

PO Box 17 03 51, D-33703 Bielefeld

Potsdamer Straße 190, D-33719 Bielefeld

Phone: +49 (0) 521 9 25 00

Fax: +49 (0) 521 9 25 24 35

Manufacturer:

Precious Science and Technology

Group Corporation Limited

NO.333, Huangjiao Road

Huangyan Area Taizhou City

Zhejiang

P. R. China



DÜRKOPP ADLER GmbH

Potsdamer Straße 190
33719 Bielefeld
GERMANY

Phone +49 (0) 521 / 925-00
E-Mail service@duerkopp-adler.com
www.duerkopp-adler.com