

Spezialnähmaschine

Serviceanleitung	D
Instructions for service	GB
Instructions de Service	F
Instrucciones de servicio	E
Istruzioni di servizio	I

General safety instructions

The non-observance of the following safety instructions can cause bodily injuries or damages to the machine.

1. The machine must only be commissioned in full knowledge of the instruction book and operated by persons with appropriate training.
2. Before putting into service also read the safety rules and instructions of the motor supplier.
3. The machine must be used only for the purpose intended. Use of the machine without the safety devices is not permitted. Observe all the relevant safety regulations.
4. When gauge parts are exchanged (e.g. needle, presser foot, needle plate, feed dog and bobbin) when threading, when the workplace is left, and during service work, the machine must be disconnected from the mains by switching off the master switch or disconnecting the mains plug.
5. Daily servicing work must be carried out only by appropriately trained persons.
6. Repairs, conversion and special maintenance work must only be carried out by technicians or persons with appropriate training.
7. For service or repair work on pneumatic systems, disconnect the machine from the compressed air supply system (max. 7-10 bar). Before disconnecting, reduce the pressure of the maintenance unit.
Exceptions to this are only adjustments and functions checks made by appropriately trained technicians.
8. Work on the electrical equipment must be carried out only by electricians or appropriately trained persons.
9. Work on parts and systems under electric current is not permitted, except as specified in regulations DIN VDE 0105.
10. Conversion or changes to the machine must be authorized by us and made only in adherence to all safety regulations.
11. For repairs, only replacement parts approved by us must be used.
12. Commissioning of the sewing head is prohibited until such time as the entire sewing unit is found to comply with EC directives.

Adler class 267
Instructions for mechanics

Edition September 1988

Contents:	Page:
1. Technical data	2, 3
2. Adjustments	
2.1 Lower feed	4-6
2.1.1 Feed dog	4, 5
2.1.2 Wheel transport	6
2.2 Hook and needle bar height	7, 8
2.2.1 Timing of looping stroke	7
2.2.2 Height of needle bar	8
2.2.3 Clearance between hook point and needle	8
2.2.4 Hook guard	8
2.3 Bobbin case lifter	9
2.3.1 In general	9
2.3.2 Lifting distance	9
2.4 Upper feed	9-12
2.4.1 In general	9
2.4.2 Needle transport	9
2.4.3 Alternating transport	9-12
2.5 Safety clutch	13
2.6 Thread tension	13
2.7 Thread pulling spring	13, 14
2.8 Thread cutter (FA/FAP)	14-18
2.8.1 Sequence of functions	14
2.8.2 Axial position of the guide cam	14
2.8.3 Position of the FA-magnet	14
2.8.4 Radial position of the guide cam, pre-positioning ..	15
2.8.5 Position of roller to guide cam	15
2.8.6 Operating arc of the thread pulling knife	15
2.8.7 Lateral position of the thread pulling knife	16
2.8.8 Cutting pressure on the counterknife	16
2.8.9 Resting position and height of the thread pulling knife	16
2.8.10 Adjusting clamping spring	16
2.8.11 Checking the radial position of the guide cam	17
2.8.12 Position maker	17, 18
3. Additional equipment	
3.1 Pneumatic presser foot lifting (FLP)	18
3.2 Automatic tacking (RAP)	18, 19
3.3 Needle bar high position (NH)	19-21
3.4 Driven wheel foot (AR)	21-23
3.5 Quick-action stroke adjustment (HP)	23
3.6 Needle positioning	24
3.7 Thread pulling device (FE)	24, 25
3.8 Roller feed (SP)	25
4. Maintenance	
4.1 Cleaning	26
4.2 Lubrication	26

1. Technical data

Class: 267- with subclasses

Subclass	:	3-5	73	373	203-S	273
- Needle system	:	134Lr	134-35	134-35	134Lr	134
- Needle size	Nm:	130	120	130	130	110
- Needle clearance	mm:	-	-	-	1,2-2,4	3-40
- Synth. sewing thread	Nm:	20/3	30/3	30/3	20/3	30/3
- Braided thread	Nm:	-	-	-	-	-
- Foot stroke, max.						
* pneumatical	mm:	-	-	-	-	-
* by hand	mm:	7	12	12	6	7
- Stitch length, max.						
* Bottom feed	mm:	6	6	6	6	6
* Upper feed	mm:	-	6	6	-	6
- Bottom feed stroke (above throat plate)	mm:	1,3	-	0,5	1,3	-
- Final feed	mm:	1,4	-	-	1,4	-
- Alternating top feed stroke	mm:	-	10	10	-	8
- Stitches/min., performed:		1.750	1.500	1.700	1.750	1.700
- Motor pulley ø	mm:	118	100	112	118	112
- Handwheel belt pully ø	mm:	95	95	95	95	95
- Motor speed 50 Hz	1/min.:	1.400	1.400	1.400	1.400	1.400

Subclass	:	273-MH1	VG-82-S	VG-373	FA-73	FA-373
- Needle system	:	134-35	134Lr	134-35	134	134-35
- Needle size	Nm:	140	90	120	120	120
- Needle clearance	mm:	3-14	-	-	-	-
- Synth. sewing thread	Nm:	30/3	60/3	30/3	30/3	30/3
- Braided thread	Nm:	-	-	-	-	-
- Foot stroke, max.						
* pneumatical	mm:	-	-	-	-	-
* by hand	mm:	7	7	12	12	12
- Stitch length, max.						
* Bottom feed	mm:	6	4	6	6	6
* Upper feed	mm:	6	4	6	6	6
- Bottom feed stroke (above throat plate)	mm:	-	-	0,5	-	0,5
- Final feed	mm:	-	-	-	-	-
- Alternating top feed stroke	mm:	8	-	10	10	10
- Stitches/min., performed:		1.700	2.200	2.000	1.700	1.700
- Motor pulley ø	mm:	112	125	140	112	112
- Handwheel belt pully ø	mm:	95	80	95	95	95
- Motor speed 50 Hz	1/min.:	1.400	1.400	1.400	1.400	1.400

Class: 267- with subclasses

Subclass	:	FA-273	FA-273-NH1	VGf-82-S	VGf-2-s	VGf-202-S
- Needle system	:	134	134-35	134KKLr	134Lr	134KKLr
- Needle size	Nm:	110	120	80	90	80
- Needle clearance	mm:	3-12	3-14	-	-	0,8-2,0
- Synth. sewing thread	Nm:	30/3	30/3	60/3	60/3	60/3
- Braided thread	Nm:	-	-	-	-	-
- Foot stroke, max.						
* pneumatical	mm:	-	-	-	-	-
* by hand	mm:	12	7	7	7	6
- Stitch length, max.						
* Bottom feed	mm:	6	6	4	4,5	4,5
* Upper feed	mm:	6	6	4	-	-
- Bottom feed stroke (above throat plate)	mm:	-	-	-	1,2	1,2
- Final feed	mm:	-	-	-	1,3	1,3
- Alternating top feed stroke	mm:	8	8	-	-	-
- Stitches/min., performed:		1.700	1.700	2.200	2.200	2.000
- Motor pulley ø	mm:	112	112	125	125	112
- Handwheel belt pully ø	mm:	95	95	80	80	80
- Motor speed 50 Hz	1/min.:	1.400	1.400	1.400	1.400	1.400

Subclass	:	FAP-3-S	FAP-203-S
- Needle system	:	134Lr	134Lr
- Needle size	Nm:	130	130
- Needle clearance	mm:	-	1,2-2,4
- Synth. sewing thread	Nm:	20/3	20/3
- Braided thread	Nm:	-	-
- Foot stroke, max.			
* pneumatical	mm:	7	6
* by hand	mm:	-	-
- Stitch length, max.			
* Bottom feed	mm:	6	6
* Upper feed	mm:	-	-
- Bottom feed stroke (above throat plate)	mm:	1,3	1,3
- Final feed	mm:	1,4	1,4
- Alternating top feed stroke	mm:	-	-
- Stitches/min., performed:		1.750	1.750
- Motor pulley ø	mm:	118	118
- Handwheel belt pully ø	mm:	95	95
- Motor speed 50 Hz	1/min.:	1.400	1.400

2. Adjustments

2.1 Lower feed

2.1.1 Feed dog

In general

The feed dog describes an elliptic path, so enabling a combined stroke and thrust movement. Stroke and thrust movement should be so adjusted that the feed dog emerges and sinks in the throat plate as vertically as is possible.

No up and downward stroke is incorporated in machines with linear thrust feed.

The feed dog moves back and forth at throat plate level.

Height of feed dog to throat plate

Machines with stroke and thrust feed

Rule:

The feed dog should be one complete tooth above the throat plate when at its highest position.

Machines with linear thrust feed

Rule:

The feed dog should stand at throat plate level

Adjustment: Fig. 2

- Set machine to stitchlength "0"
- By turning the handwheel, advance the feed dog to its highest position
- Loosen screws a and adjust the height of the feed dog bar A accordingly.

Location of the feed dog in the throat plate

Lateral location

Rule:

The lateral positioning of the feed dog in the throat plate should be central.

Adjustment: Fig. 2

- Set to stitchlength "0"
- Loosen screws c
- Slide feed shaft B accordingly and lock with centering screws C

Location in thrust plane, fig. 2

Rule:

At max. stitchlength, the feed dog should have the same clearance fore and aft in the throat plate.

Adjustment: Fig. 2

- Set to max. stitchlength
- Loosen screw b
- Rotate feed shaft B accordingly

Timing of feed dog stroke

Machines without needle bar feed

Rule:

The needle bar and feed dog should reach their highest points simultaneously.

Machines with needle bar feed and alternating feed dogs

Rule:

At the lowest position of the needle bar, the feed dog bar should be at its highest point.

When correctly adjusted, the descending needle and the rising feed dog reach throat plate height simultaneously.

Adjustment: Fig. 2

- Set stitch regulator to "0"
- Advance needle bar to lowest point
- Loosen screws k and turn the eccentric K accordingly

Feed dog thrust timing

Machines without needle bar feed

Rule:

When the machine is advanced beyond the highest point of the thread take up lever by turning the handwheel, the feed dog should make approx. 1/2 toothlength of movement.

This "after-thrust" ensures a firmer stitch.

Observation:

To remove the arm coverplate on machines with pneumatic backtacking automatic, RAP, the turning knob E must be dismantled, fig. 5:

- Unscrew e
- Take off turning knob E
- Turn back screw f

Machines with needle bar feed and alternating feed

Rule:

At the lowest needle bar position, the feed dog and the needle should not move when the stitch regulator lever is adjusted.

This influences the timing of the thrust movement of the transport foot, as the thrust movement for feed dog, needle bar rocker and transport foot is provided by the same eccentric.

Adjustment: Fig. 3

- Set to max. stitchlength
- Bring needle bar to lowest position
- Loosen screws b and re-set eccentric B accordingly.
(By rotating the eccentric 180° on the shaft, the direction of feed is reversed.)

Indication:

At this setting the elliptic path of the feed dog is displaced. Therefore the stroke timing must be re-adjusted, see "Timing of feed dog stroke"

2.1.2 Intermittent wheel feed

Sequence of movements, fig. 11

Hook shaft A - Eccentric B - Pullrod C - Crank D - Shaft E - Crank F
Pullrod G - Gate H - Feed shaft with overrun J - Transport wheel K

The back-stop on the overrun prevents backwards running so that only a forward feed movement is transmitted to the transport wheel.

Adjusting the max. stitchlength, fig. 11

Rule:

The max. stitchlength for machines with wheel feed is 4 mm

Control:

- Apply pressure to pin M and turn handwheel till pin engages
- With the pin engaged, turn the handwheel in the reverse direction to the stop (max. stitchlength)
- Sample sew and measure stitchlength.

Correction:

Loosen nut g and re-set pullrod G in the gate H
towards overrun clutch J: smaller stitches
in opposite direction: larger stitches.

Adjusting stitchlength

Rule:

At max. stitchlength, the letter H should be visible in the window

Control:

Adjust to max. stitchlength and observe the letter visible in the window.

Correction:

Loosen screws r and turn scale wheel R accordingly

Thrust timing of the transport wheel

Rule:

When the machine is advanced by the handwheel, at max. stitchlength, beyond the highest position of the thread take-up lever, the transport wheel should still advance for approx. 1/2 toothlength.
This "afterthrust" ensures better knotting.

Adjustment: Fig. 3

- Set to max. stitchlength
- Advance to thread take up top position
- Loosen screws b and set feed eccentric B accordingly

Height of transport wheel

The transport wheel should protrude approx. the height of one tooth above the throat plate.

To correct: fig. 11

Loosen screws v and adjust the height with screws w.

2.2 Hook and needle bar height

When checking or adjusting the hook, the safety clutch must be engaged.

2.2.1 Timing of looping stroke

The looping stroke is the distance the needle makes from its lowest point upwards to form a loop in the thread which is then caught by the hook .

Regel:

By the sub-classes -4-S, -FAP-4-S, -204-S, and FAP-204-S 2 mm) when the needle has risen 1,8 mm above its lowest point, the hook point should stand at mid-needle position. (Looping stroke position)

Preparation:

Remove sliding plate, dismantel throat plate and feed dog

Control: Abb. 8

- Set stitchlength to 0 and advance needle bar to its lowest position
- Push gauge (part No. 981 15 000 1 = 1,8 mm) or (part No 981 15 000 3 = 2,0 mm) together with block (part No 981 15 000 2) onto the needle bar against the rocker and screw tight the block, (take care not to damage the needle bar by screwing too tightly)
- Remove gauge and advance handwheel *in running direction* until the block rests against the rocker (looping stroke position)
- Check the position of hook point to needle, fig. 6

Correction:

Vertical hook, fig. 1 + 4

- Unscrew grease pot housing G
- Loosen the screws in the large bevel gear wheel
- Set up the hook point to middle of needle at looping stroke position
- Bring the bevel gears to mesh without tightness (The hook should have some radial play).

Horizontal hook, fig. 7

- Loosen hook screws a slightly so as to allow the hook to be turned by hand on the shaft.
- Set up the hook point to middle of needle position in the looping stroke position.

2.2.2 Height of needle bar

Rule:

In the looping stroke position, the hook point should stand at the middle of the needle ear, fig. 6 + 7

Adjustment: Fig. 12

- Remove head cover
- Loosen screw o and adjust the height of the needle bar accordingly.

2.2.3 Clearance between hook point and needle

Rule:

In looping stroke position, and with correct needle bar height, the hook point should have approx. 0,1 mm clearance to needle without touching hook guard, fig. 6 + 7

Adjustment:

Vertical hook, fig. 1 + 4

- Remove grease box G
- Loosen the screws p on the hook shaft bearing and re-set the position of the hook, if necessary, loosen the bevel gear screws.
- Re-tighten the screws on the hook shaft bearing
- Re-tighten bevel gears allowing for easy running
- Screw grease box.

Horizontal hook, fig. 7

Slacken hook screws to allow hook to be slid on the shaft

Indication:

When needles of another thickness are used, the clearance between hook point and needle must be checked and if necessary re-adjusted

2.2.4 Hook guard

The hook guard prevents the hook point hitting the needle

Vertical hook

Rule:

In the looping stroke position, the needle should rest on the guard V without being deflected, fig. 6

Control:

Lightly press the needle against the hook guard. The needle should not come into contact with the hook point.

Control:

Bend the hook guard carefully

Indication:

If other needle thicknesses are used, the hook guard must be checked and if necessary re-adjusted.

Horizontal hook

The middle piece of the hook is so formed, that the hook point is protected when the hook clearance to needle is correct.

2.3 Bobbin case lifter

2.3.1 In general

The middle piece of the hook (bobbin case) is "lifted" at the moment the thread is pulled between the bobbin case and the holder. The tension on the thread is reduced.

The timing of the "lifting" is constructionally fixed and cannot be altered.

2.3.2 Lifting distance, fig 18

Rule:

The finger G should lift the bobbin case K to thread thickness

By too little lifting, tension is not reduced, too much lifting produces mechanical clatter

Adjustment:

Loosen screw h and turn carrier plate H.

2.4 Upper feed

2.4.1 In general

The thrust movement of the feed dog and the needle bar transport is controlled by the eccentric B/3 on the arm shaft.

The timing of the feed dog thrust also applies to the movement of the needle bar transport.

2.4.2 Needle transport

Set up needle bar to throat plate

Rule:

At stitchlength 0 setting the needle should enter the throat plate centrally when the machine is advanced in sewing direction.

Adjustment: Fig. 3

- Set to stitchlength 0
- Loosen screw w and align needle bar rocker accordingly

2.4.3 Alternating feed

Lifting height of the feet

Rule:

When sewing materials of various thickness within one seam length, the height of the feet should be adjusted to the thickest material.

Adjustment: Fig. 10

Loosen nut h and re-set the pullrod in the guide track H:
pullrod up = max. stroke
pullrod down = min. stroke

Maximum stroke of the presser foot

The through-put height under the presser foot is quoted in the sub-class table.

Machines without alternating feed

Handlever stroke

Control:

- Lift the presser foot using the hand lever
- According to sub-class, place distance piece (6 or 7 mm) under the presser foot

Correction: fig. 9 + 12

- Release spring P and loosen clamp v
- Lay distance piece under the presser foot and re-tighten clamp.

Knee lever or pneumatic foot lifting (FLP) stroke

Rule:

The knee lever or FLP stroke should be slightly higher than the stroke commanded by the hand lever, so that hand raised foot can be lowered by the knee lever or the FLP

Control:

- Lift presser foot using the hand lever
- Press knee lever hard to the right or operate FLP - the hand lever should automatically clap down to allow the presser foot to be lowered.

Correction on knee lever support: Fig. 13 + 17

Turn in screw v/17 so far, that when the presser foot is lowered, the support N does not rest on the plate L.

Rule:

The lever V should rest on the screwhead to limit the stroke when the presser foot is raised, fig. 16

Correction:

Turn back screw f and re-adjust the control rods F.

Correction of the FLP-stroke: Fig. 14

Arrange control rod F so that when the piston rod of the FLP-cylinder is extended, the stroke is slightly longer than that of the hand lever - use screw f.

Machines with alternating upper feed

Hand lever stroke

Rule:

The presser foot should be raised 7 mm by the hand lever.

Control:

- Set to stitchlength 0 and remove the needle
- Raise presser foot using the hand lever
- Advance feed dog to throat plate height
- It should be possible to pass a 7 mm distance piece under the presser foot.

Correction: Fig. 9 + 13

- Release tension on spring P and loosen clamp w/13
- place 7 mm distance piece under the presser foot and press down the foot.
- Re-tighten clamp

Knee lever or FLP-stroke

The through-put height of the presser foot which has been raised using the knee lever or FLP is quoted in the sub-class tables.

Control:

- Set to stitchlength 0 and advance until thread take up lever is at its lowest point
- Lift presser foot using knee lever or FLP
- According to su-class, it should be possible to pass a 12 mm/13 mm distance piece under the presser foot

Correction on knee lever support:

- Turn back screw v/17 until the lever V/17 is not quite touching the casting.
- Set control rod F/14 so, that enough play is given between carrier N/13 and plate L/13 to allow the presser foot to rest firmly on the throat plate - by turning back screw f/14.

Position of knee lever

Rule:

The knee lever should stand vertically

Correction of the position of the knee lever:

Loosen the clamp t on lever T, fig. 15

Correction of the setting of the FLP:

Field of swing of the lever

Rule:

When the piston rod of the FLP-cylinder is fully extended, the lever V should have a clearance of 0,5 - 1 mm to bearing L, fig. 21

Control:

Operate FLP and measure the clearance.

Correction: Fig. 21,

Loosen nut 1 and turn the piston rod

Adjusting the stroke

Correction of the FLP-stroke:

Set control rod F/14 so, that enough play is given between carrier N/13 and plate L/13 to allow the presser foot to rest firmly on the throat plate - by turning back screw f/14.

Simultaneous lifting of the feet

Rule:

The height of the lifting stroke for feed and presser feet should be the same.

Adjustment: Fig. 9

- Set stitchlength to 0
- Set lifting stroke to max. height
- Advance until the foot with the longer stroke is slightly raised from the throat plate
- Loosen screw p and press down the foot unto the throat plate
- Repeat until the stroke is identical for both feet.

Stroke timing of the upper feed foot

Rule:

The descending upper feed foot and descending needle bar should be, together with the rising feed dog, simultaneously at throat plate level.

Pre-requirement for the adjustment is the uniform lifting of upper feed and presser feet

Control:

At max. stroke and stitchlength 0 settings, turn handwheel in sewing direction

Adjustment: Fig. 19

- Loosen screws of the stroke eccentric T (through the hole in the rear wall of the machine) on the arm shaft
- Bring the point of the descending needle to feed dog level
- Turn the eccentric until the upper feed foot rests on the feed dog.
- Retighten the eccentric screws

Indication:

When the stroke eccentric is turned 180°, the upper feed foot rises when the needle pierces the material.

2.5 Safety clutch

To avoid damage caused by a blocked hook (i.e. threads tangling in the hook housing), the safety clutch should disengage on overload.

Freeing blocked hook: Abb. 21

- Eliminate cause
- Hold shaft G and turn handwheel till clutch engages.

Indication:

When the clutch is correctly engaged, it should be possible to insert 5 mm pin into the drilling n/15 in both parts of the clutch. With correctly engaged clutch, movement of hook and needle are again synchronous.

Adjusting torque, fig. 15

Adjust torque only with clutch engaged:

- Disengage clutch
- Screw in fully screws d and then 1/4 turn back (max. torque)
- Turn back screws so far that a medium amount of torque is applied
- Should the clutch regularly disengage when sewing heavy materials, the amount of torque can be increased.

2.6 Releasing thread tension, fig. 19

The upper thread main tension is released by the magnet M or the cylinder during the FA-operation, so that the loop in the upper thread can be pulled by the thread pulling knife.

The thread "lifting" timing is determined by the motor control. At this moment only the pre-tension is effective so that the length of the upper thread cut is dependent upon the pre-tension.

Rule:

The tensioning discs on the upper thread main tensioner should be opened wide enough apart so that the thread can run free.

Adjustment:

Make adjustments with screw k, fig. 10.

2.7 Thread take up spring

Thread tension, fig. 23

Rule:

The spring tension should be regulated according to sewing material and thread so that it works evenly and returns fully.

Adjustment:

Loosen screw f and turn bolt F.

Spring deflection

Rule:

The spring should be at rest when the eye of the needle enters the material.

Adjustment:

Loosen screw g and adjust the stop accordingly.

2.8 Thread cutter FA/FAP

2.8.1 Sequence of functions, fig. 18, 19, 21

- The FA-sequence is carried out (after backtacking), at the end of a seam by depressing backwards the pedal from the 1st. position
- The motor runs at cutting speed
 - The magnet M/19 releases the upper thread tension during the whole FA-sequence.
 - The active FA-magnet W/21 (by FAP, the cylinder) swings out the thread pulling knife, so that upper and lower threads fall behind the cutting knife.
 - The FA-magnet (by FAP, the cylinder) is de-energised.
 - The guide cam S/21 swings the thread pulling knife back against the counter knife Z/18, whereby upper and lower threads are caught by the thread pulling knife, pulled tight, and cut between thread take-up lever high position and 2nd. position.
 - The clamping spring O/18 holds the cut threads
 - The motor stops in the 2nd. position, and the magnet for the upper thread main tension is de-energised.

2.8.2 Axial position of the guide cam, fig. 21

Rule:

The guide cam S should rest axially against the bush T

Adjustment:

Loosen screws s and push the cam against the bushing.

2.8.3 Position of FA-magnet

Rule:

When energised, the armature of the magnet should not hit the magnet plate.

Adjustment: Fig. 21 + 22

- Loosen screws u (3 x)
- With the handwheel, advance the machine until the deepest point of the guide cam is opposite the roller R
- Slide the magnet armature P/21 as far as possible to the right until the roller rests on the deepest point of the cam
- Push body of magnet W/21 fully to the left with stop against the armature, then set up approx. 1 mm of play between armature and magnet plate.
- Retighten screws u

2.8.4 Radial position of the guide cam, pre-adjustment

The position of the guide cam determines the moment when the knife swings out

Rule:

At the lowest position of the thread take up lever, the roller R, (in sewing direction) should rest at the start of the deepest point of the cam S, fig. 22

Adjustment: Fig. 21

- Advance to lowest position of thread take-up lever
- Loosen screws s and adjust guide cam accordingly.

Indication:

The axial position of the guide cam must not be altered. (See 2.8.2)

2.8.5 Adjusting the position of cam to roller, fig. 21

Rule:

During the sewing sequence, the roller R should not touch guide cam S

Adjustment:

- Loosen screws h
- Advance the handwheel until the highest point of the guide cam is opposite the roller
- Adjust stop H to lever K so that the roller can be lightly turned
- Retighten screws h

2.8.6 Range of swing of the thread pulling knife

Rule:

The thread pulling knife should swing out so far from its resting position that the threads are accurately caught and then swing far enough back to ensure that the threads are cut cleanly.

When swinging out, the thread pulling knife should not hit the base plate, when swinging back, the lever F should not touch the grease box G, fig. 1

Adjustment: Fig. 1

- Loosen the nuts of the pullrod Z
- Turn the handwheel until the deepest part of the guide cam is opposite the roller
- Press gauge (part No. 981 35 000 1) onto the roller
- Press lever F to the right, so that the roller rests on the deepest point of the cam.
- Using pullrod Z, set up the lever F so that the two holes in the lever are vertically in line (mid swing position)
- Remove gauge and check that lever F does not come into contact with grease box G, otherwise re-adjust.

2.8.7 Lateral position of the thread pulling knife, fig. 18

Rule:

The thread pulling knife F should move freely centrally between middle piece holder E and bobbin case.

Adjustment:

Loosen screws f and adjust thread pulling knife accordingly.

2.8.8 Adjusting the counter knife cutting pressure, fig. 18

Rule:

The counter knife should engage with the returning thread pulling knife after approx. 1/3 of its width.

Adjustment:

Loosen screws n and set up counter knife holder N accordingly.

2.8.9 Resting position and height of the thread pulling knife

Rule:

In its resting position, the rear edge of the thread pulling knife should align with the front edge of the counter knife.

The height of the thread pulling knife is not variable

The knife holder shaft E should stand hard against the lever F, fig. 4

Adjustment:

- Advance the handwheel until the highest point of the guide cam is opposite the roller
- Loosen screw f and press knife holder and lever against each other, at the same time adjust the thread pulling knife to the counter knife.
- Retighten screw f

2.8.10 Adjusting clamping spring, Fig. 18

Rule:

The clamping spring O should hold the cut off bobbin threads, to avoid tangling threads at the start of the next seam

Adjustment:

- Loosen screws o
- Adjust clamping spring so that it rests on the inside of thread pulling knife.

2.8.11 Radial position of the guide cam, check

Rule:

At the thread take up lever high position, the roller R should stand at the start of the highest point on the guide cam S when the machine is advanced forwardly, fig. 21

Control:

- Advance machine to thread take up lever high position
- Check the position of the cam
- If incorrect, loosen screws s and re-set cam, (the axial position of the cam must not be altered, point 2.8.2).

2.8.12 Position maker

1st. position

Rule:

The hook point is 4-8 mm behind the needle

The hook has caught the loop securely, so that the material can be turned around the needle.

The switch b5/S17 on the control box stands at "needle down" position, fig. 26 + 27

In order that sewing material can be turned by twin needle machines, the switch stands at "needle up" position during sewing i.e., the machine positions in the 2nd. position

Adjustment to the positions maker:

Switch to "needle down" position

Control:

- Depress pedal forwards and release
- Check positioning operation, if necessary correct the position of screen

Correction:

Advance to 1st. position using handwheel

Quick type B/0, fig. 29

- Slacken off screw c slightly
- Align switching edge s of the screen B under the notch in the sliding screen A

Efka type P4-1, fig. 30

- Slacken off screw c slightly
- Set switching disc A so that both white spots are half covered by the screens.

Efka type P4-4, fig. 28

- Slacken screw c slightly
- Set disc 1 so that the edge a opens the way for the light beam L. Take care not to alter disc 2, otherwise the opening time for the thread-end pulling device will be altered.

2nd. position

Rule:

The thread take up lever has just passed the highest position.
With the FA-unit correctly set up, the roller rests on the highest point of the guide cam and the threads have been cut

Control:

- Test sew and operate FA sequence
- Check positioning and if necessary adjust the screen setting

Correction:

Advance to 2nd. position using the handwheel

Quick type B/0, fig. 29

Align the switching edge s of the nosed-screen C under the notch in the sliding screen A.

Efka type P4-1, fig. 30

Set up the switching disc B so that both white marks are half covered by the screens.

Efka type P4-4, fig. 28

Set up disc 3 so that the edge a opens the way for the light beam L. Take care not to alter disc 4. Otherwise the closing time of the FE will be altered.

Indication:

By twin-needle machines, set the switch for the needle position in the 1st. position again to "needle up".

3. Additional equipment

3.1 Pneumatic presser foot lifting (FLP)

Adjusting the FLP see "Machines with alternating upper feed".

3.2 Pneumatic back-tacking automatic (RAP)

In general, fig. 32

The RAP-cylinder 2.4 requires a constant air supply of 6 bar.
The adjustment of the number of back-tacking stitches is described in the motor manufacturers hand-book.

Function

Forward sewing

The RAP-cylinder is not under pressure, the piston rod is extended by spring power.

Back-tacking

The cylinder is put under pressure, the piston-rod retracts and switches over the stitch regulator.

Damping, fig. 32

Rule:

By regulating the damping valves 2.2 und 2.3 the speed of the piston-rod should be controlled so that it does not reach the ends of its stroke too abruptly.

The retraction of the piston-rod, (back-tacking) ist controlled by valve 2.3, valve 2.2 controls the extension of the piston-rod (forward sewing).

Length of back-tack stitches, fig.5

The length of the back-tack stitches can be varied by the turning knob E without altering the forward stitches.

When altering the length of the forward stitches, the back-tacking stitches should be altered to match.

3.3 Raised needle bar position (NH)

In general

On twin-needle machines with raised needle bar position NH, the right or left needle bar can be held stationary in the raised position.

The driven needle bar is connected to the T-bar L by the three upper steel balls.

The un-driven needle bar is held in the raised position by the lower three steel balls, fig. 46 + 47.

Dismantle needle bar rocker, fig. 12 + 31

- Both needle bars must be engaged to remove the rocker
- Remove screw d and take off locking cam F
- Dismantle angle Z/12
- Remove screws f and take off the bearing plate with the complete needle bar rocker

Dismantle needle bar, fig. 45, 46, 47

- Remove guide block U
- Disengage needle bar to be removed by sliding the block S over the needle bar and slide the T-bar L upwards until the three balls audibly engage.
- Push down T-bar for a distance of approx. half the needle bar stroke
- Remove screw c, loosen the screw below and take out the thrust piece D
- Push down clamping ring C and take out the divided retaining ring e
- Engage the needle bar in the middle position by sliding the block S accordingly
- Slide T-bar L carefully upwards till the upper three balls emerge.

Attention: The balls are under spring pressure!

- Extract needle bar carefully

Attention: The lower three balls fall out thereby!

Dismantling needle bar, fig. 47

- Unscrew needle holder
- Turn out screw s
- Take out bolt n and the internal parts.

Assembling needle bar, fig. 47

- Retighten closure screw v, if it has been loosened
- Fit together the parts of the lower coupling bar:
- Push conical sleeve h together with the cone hub down onto the spring bar i
- Slide 18,5 mm spring g onto the spring bar
- Screw on counter nut l and domed head nut k and adjust to measure 30,5 mm
- Push the 12 mm long spring and sleeve H onto the smaller boss on the coupling bar T
- Insert coupling bar with the larger boss first into the needle bar
- Push taper pin b as in fig. into the needle bar.
- Slide the pre-assembled lower coupling bar with the domed head nut ahead into the needle bar.
- Insert the 22 mm long spring f.
- Screw in bolt n, with the threaded hole first and tighten
- Check for easy movement of the coupling mechanism by depressing the upper coupling bar.

Assemble needle bar in the rocker, fig. 45 + 46

- Insert needle bar in the lower part of the rocker.
- Slide T-bar L and clamping ring C onto the needle bar, whereby the slimmer walls of the clamping ring should be opposite the other needle bar.
- Slide needle bar further, until the drillings for the lower steel balls are just under the lower needle bar bearing.
- Insert the steel balls in the lower drillings and carefully slide the needle bar further until the balls are no longer visible.
- Insert the steel balls in the upper drillings, *hold the needle bar*, press the upper coupling bar T in the needle bar and slide the T-bar L over the upper steel balls.

Attention: Do not slide the needle bar further to avoid the spring loaded steel balls escaping!

- Slide clamping ring C under the groove in the needle bar
- Lay the divided retainer ring e in the groove and push the clamping over it to the stop.
- Press T-bar L until it stops against the clamping ring C, the needle bar is thereby coupled to the T-bar.
- Assemble needle holder and screw tight
- Turn the needle bar so that both flat surfaces on the needle holders are in line
- Lay thrust piece D in the clamping ring C so that it form locks onto the needle bar.
- Screw thrust piece on tightly and secure with second screw c
- Insert both clamping rings with the curved sides in the guide fork Z
- Screw on the guide block U.

Assemble needle bar rocker

The needle bar rocker assembly is in the reverse order to the dismantling.

3.4 Driven roller feed (AR)

- AR 1: Only forward feed (for machines with wheel feed)
- AR 2: Forward feeding and free-wheeling in reverse (for machines with RAP), the toothed wheels of roller foot are disengaged when back-tacking

Sequence of movements, fig. 25

Arm shaft A - Eccentric B - Fork C - Rocker D - Pullrod E - Crank F
Shaft G - Pullrod H - Roller foot J.

Position of the roller foot

Rule:

The roller foot should be parallel to the feed dog.

Adjustment:

Loosen screw r, fig. 34

Rule:

The roller foot should rest on the material approx. 1 mm behind the needle.

Correction: Fig. 35

- Disconnect pullrod E by removing screw e
- Loosen screw s/38 and re-set roller foot carrier in the guide track

Rule:

The sole of the roller foot should stand parallel to the feed dog.

Correction: Fig. 38

- Loosen nut t and adjust the roller foot using screw u.
If it is not possible to adjust the roller foot, or if there is play between the catch W and the lever U (roller foot wabbles), fig. 37:
- Loosen screw s and adjust lever U

Distance between roller foot and needle

Rule:

The roller foot should stand approx. 0,5 mm to the side of the needle

Correction:

Loosen screw r and turn the eccentric sleeve R, fig. 34

Disengaging the roller foot toothed wheels on AR 2

When the stitch regulator is switched from forwards to backwards sewing, the gear wheels in the roller foot are disengaged. Therefore the roller foot runs free when back-tacking.

Reach of the lever, fig. 34 + 37

Rule:

Lever M should depress pin N so far, that it is possible to turn the roller foot freely backwards and forwards.

Disengagement via bowden cable, fig. 33

At max. stitchlength, with screw d, adjust the lever D so that there is approx. 0,5 mm play between lever M/34 and roller foot.

Disengagement via penumatic cylinder, fig. 36

Correct with screw p

When the setting is correct turn screw r/39 to restrain the cylinder pressure against the lever.

Timing of disengagement

Rule:

The gear wheels in the roller foot should be disengaged when the stitch regulator is set to 0.

The roller foot can then be turned easily forwards and backwards by hand.

Disengagement via bowden cable

Correction:

Adjust the height of the sleeve after loosening the clamp e, fig. 33

Disengagement via pneumatic cylinder

Correction:

Loosen screws f/43 and re-set the switch F/43 in the elongated holes.

3.5 Quick stroke adjustment (HP), fig. 32

For machines with alternating upper feed OT. the stroke height of the feet can be increased while sewing to cope with cross seams: by HP 11-1: with the knee lever 5.1, by HP 11-2: with the left pedal

Stroke height, fig. 20

Minimum stroke height - Piston rod of HP-cylinder extended, pullrod P in the lower end of the gate

Maximum stroke height - Piston rod retracted, pullrod in the upper end of the gate

Rule:

The distance the pull rod travels in the gate should be restricted by the piston rod to prevent the pullrod escaping from the gate.

Correction:

Remove cylinder in the elongated hole n

Should be bolt nevertheless reach the end of the gate, loosen nut s and turn the piston rod.

Indication:

Adjust nuts t so that the pull rod moves lightly in the gate

Reduction of running speed during the HP-function

To much speed by max. stroke of the sewing feet causes heavy wear and increased mechanical noise.

Machines with HP 11-2 should be so adjusted that the screw z under the left pedal allows approx. 1/3 reduction of sewing speed at max. stroke height, fig. 40.

3.6 Needle positioning (NP)

FA-machines come to a stop after the thread cutting sequence and in the thread take up lever top position. By fully raised presser foot, the point of the needle can protrude beneath the presser foot. To be able to make full use of the presser foot lifting stroke and not to damage the material, the needle bar must be turned back so far, with the NP, till the point of the needle no longer protrudes under the foot.

The position of the clamping ring M on the arm shaft and the piston rod speed determine the needle position, fig. 24

Rule:

By turning the clamping ring M in the sewing direction of the handwheel, the needle will be positioned higher.

Correction:

Remove the belt guard and adjust the clamping ring accordingly. The cylinder should be controlled with the pressure regulating valve 4.2 to ensure reliable positioning, fig. 32

3.7 Thread pulling device (FE)

At the start of a new seam, after the FA-operation, the loose end of the thread is sewn to the under side of the material.

Sequence of functions

1st. phase:

- At the moment the needle enters the throatplate, disc 4 triggers the closure of the FE, the thread is clamped
- The descending needle pulls the loose end of the thread, through the material down to the bottom position of the needle bar.

2nd. phase:

- The Hook catches the loop and pulls the loose end under the throat plate
- Disc 2 triggers the opening of the FE when the thread take up lever is at its lowest point.

Timing of closing and opening

Rule:

The FE should close when the needle enters the throat plate, and open when the thread take up lever is at its lowest point.

Control:

- With the motor switched off, remove the V-belt from the motor pulley
- Move take-up lever in top position (2nd position)
- Switch on motor and depress pedal forwards
- Advance handwheel and observe the closing and opening of the FE

Correction of the timing of closure: Fig. 28

- Advance till point of needle is at throat plate level
- Adjust disc 4 so that edge b covers the light barrier L.

Correction of the opening timing: Fig. 28

- Advance to lowest position of thread take up lever
- Adjust disc 2 so that edge b covers the light barrier L.

3.8 Roller feed (SP)

When sewing and by raised feed roller, the head of the pull rod S should not touch the roller carrier R, fig. 42

Control:

Advance the machine by hand and raise the roller

Correction:

Loosen screws n and adjust the pullrod N.

Transport timing

Rule:

The roller feed transportation should start synchronously with the lower feed.

Control:

Advance the machine by hand at max roller feed distance and max. stitchlength.

To correct, Fig. 41 + 44,

Loosen screw p (using allen key through the hole in the belt guard), and by turning the handwheel adjust the transport timing of the eccentric P.

Transport distance, fig. 41 + 44

The transporting distance of the feed roller must coincide with the stitchlength. Adjustable by altering the position of the pull rod T in the gate U/44:

Pull rod in the upper end of the gate: maximum transport distance

Pull rod in the lower end of the gate: minimum transport distance

The feed roller pressure can be regulated by the screw F, fig. 42.

4. Maintenance

4.1 Cleaning

In case of an intense service the cleaning should be done daily.
Clean by a soft brush the throat plate, the hook and the feed dog.

4.2 Lubrication

Lubrication plan see spare part list to cl. 267.
In case of an intense service lubricate daily with brand oil only.
Use brand oil, e.g. ESSO MILLCOT K 68, with following refence data:

Viscosity at 40° C: 65 mm /s

Flashpoint : 212° C

ESSO MILLCOT K 68 can be obtained from Kochs Adler:

1 l Part-No. 990 47 012 8

5 l Part-No. 990 47 012 9

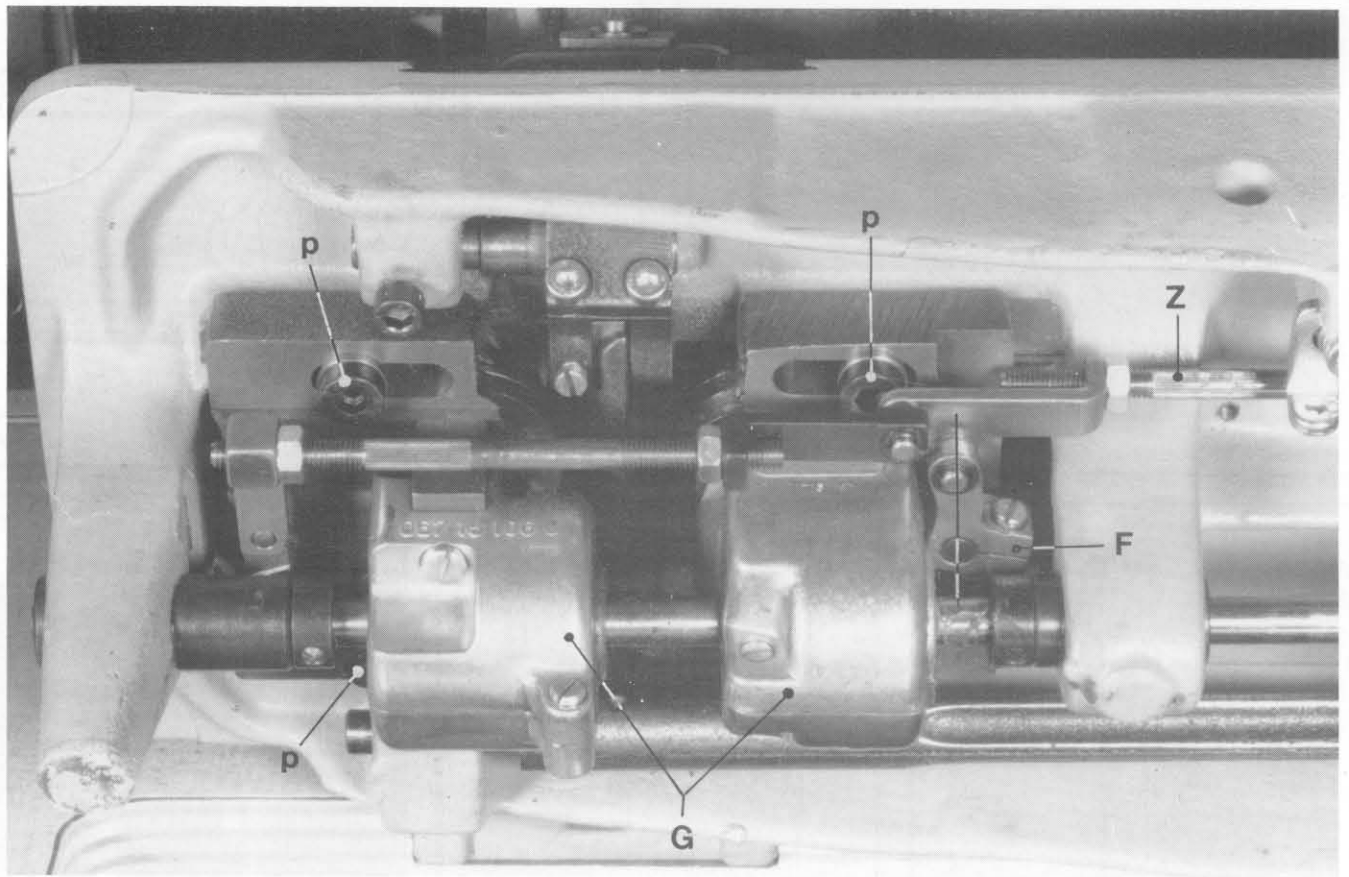

1

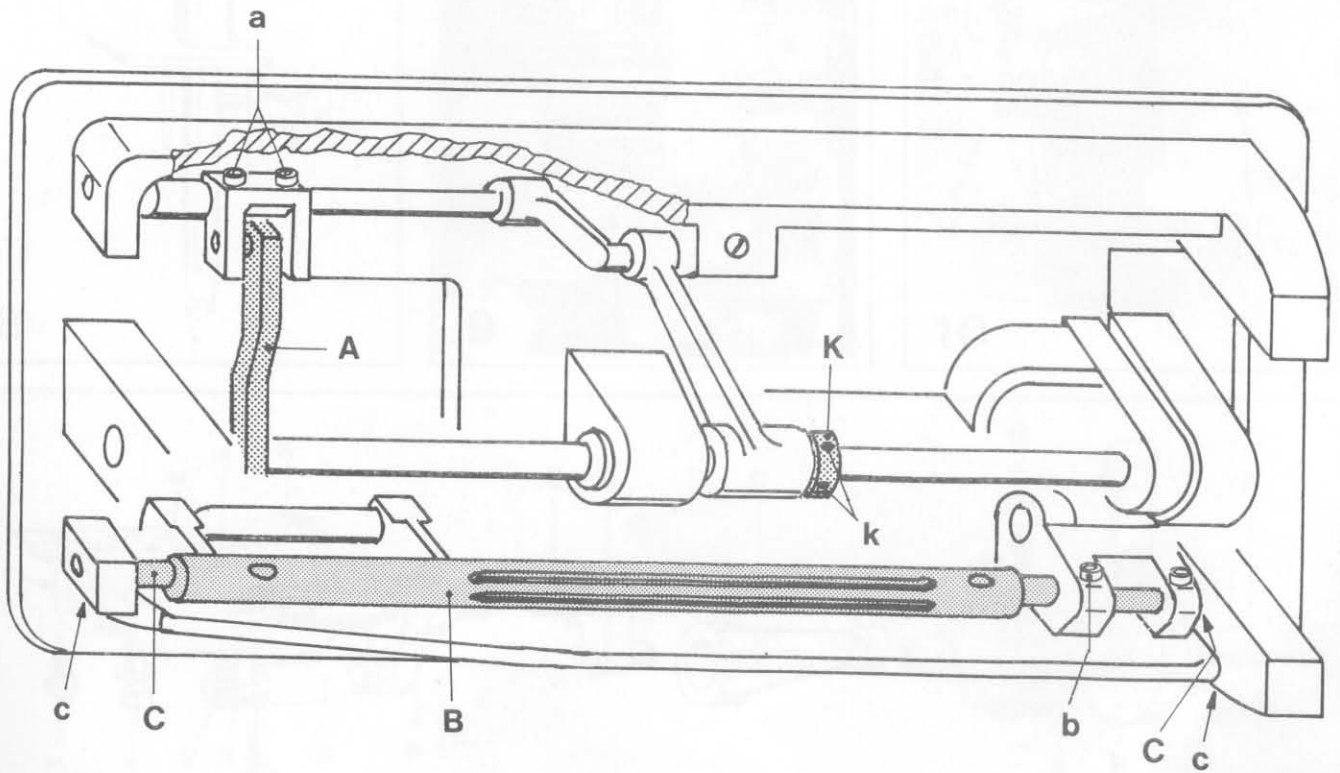

2

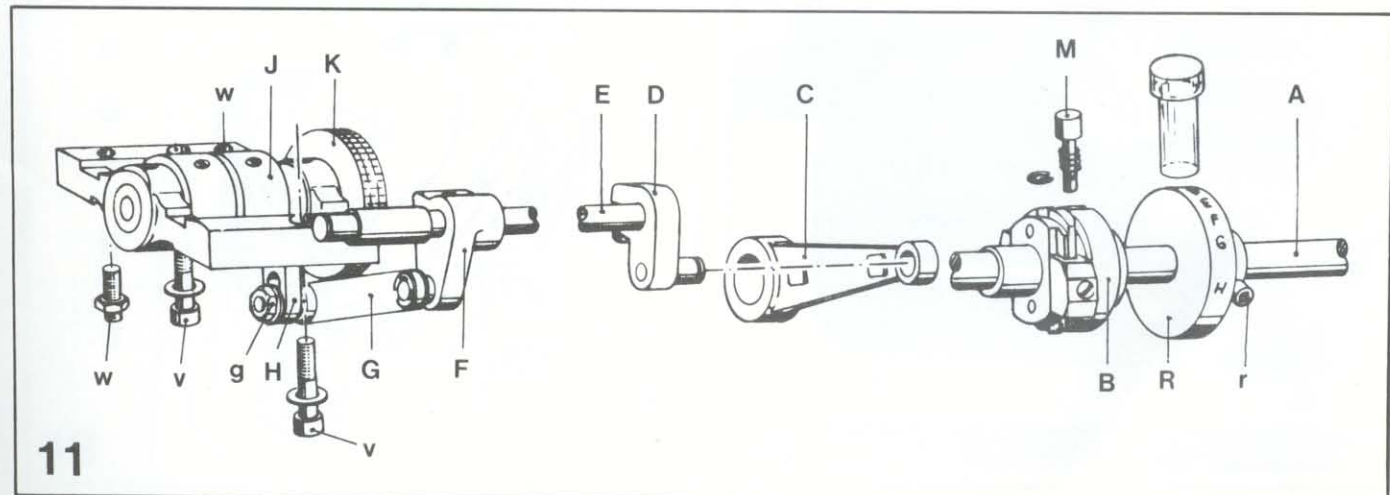
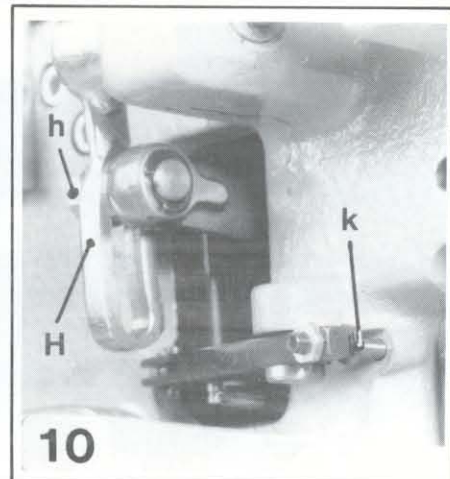
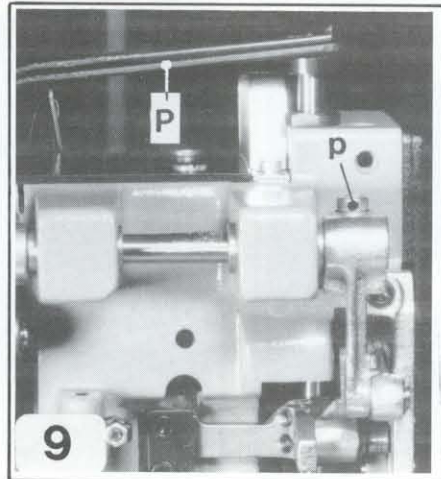
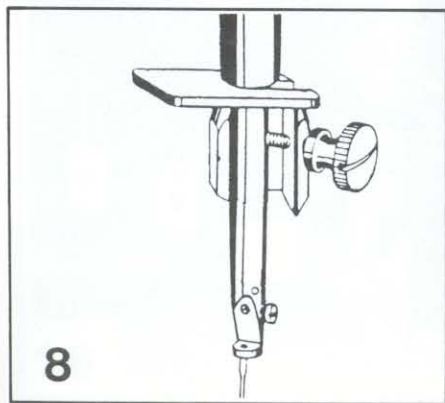
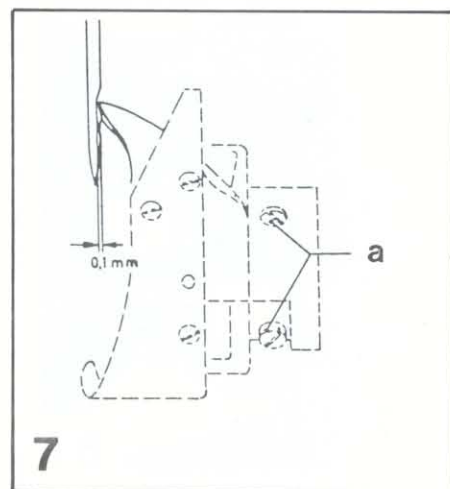
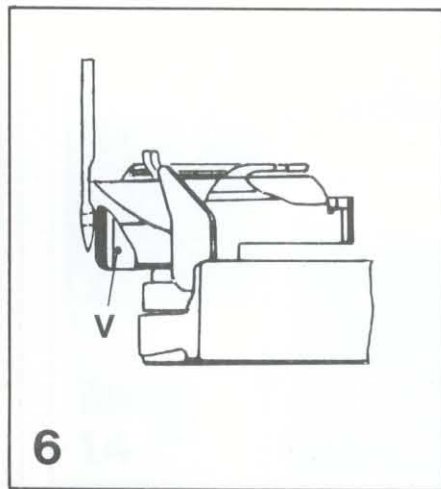
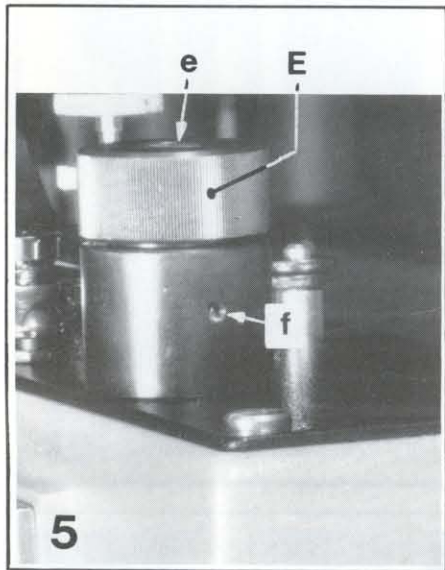
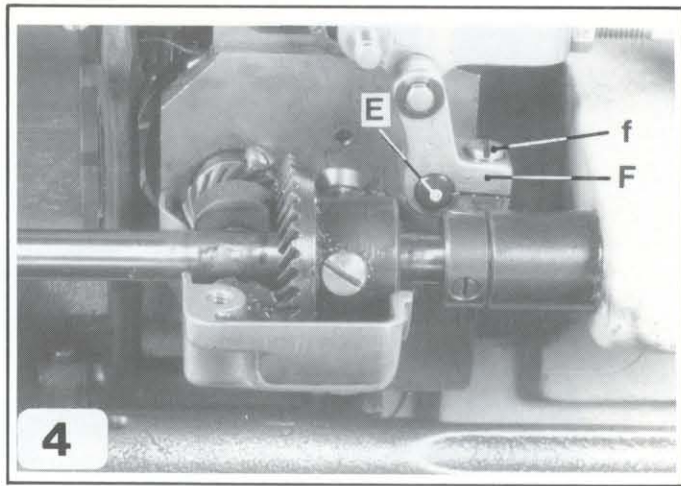
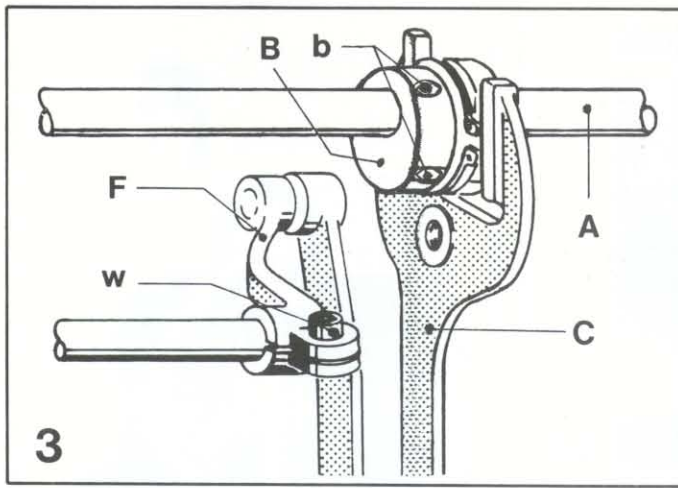

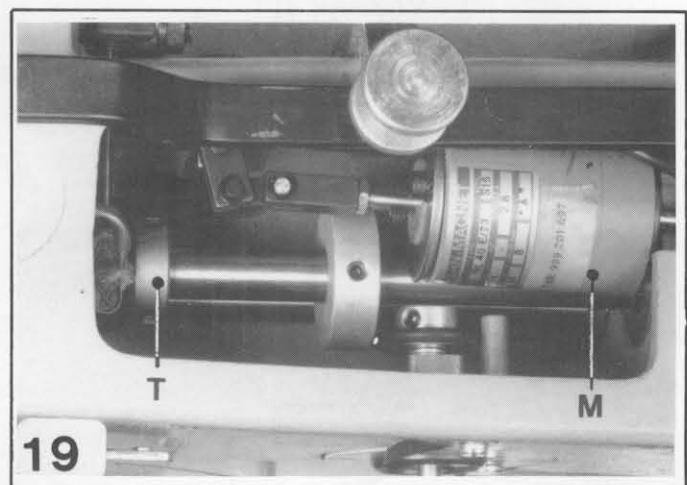
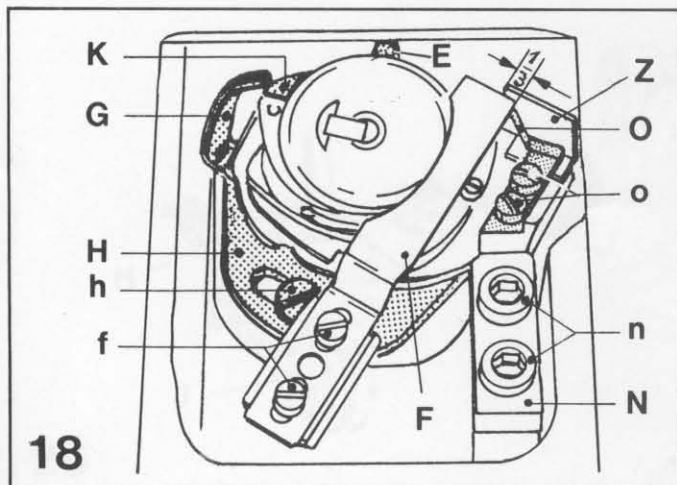
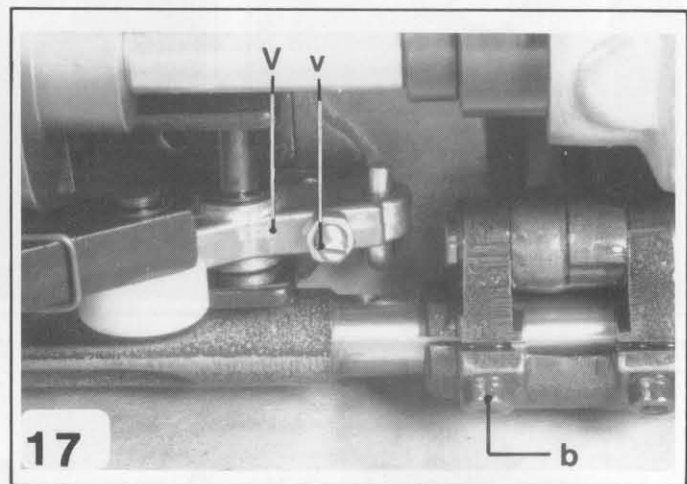
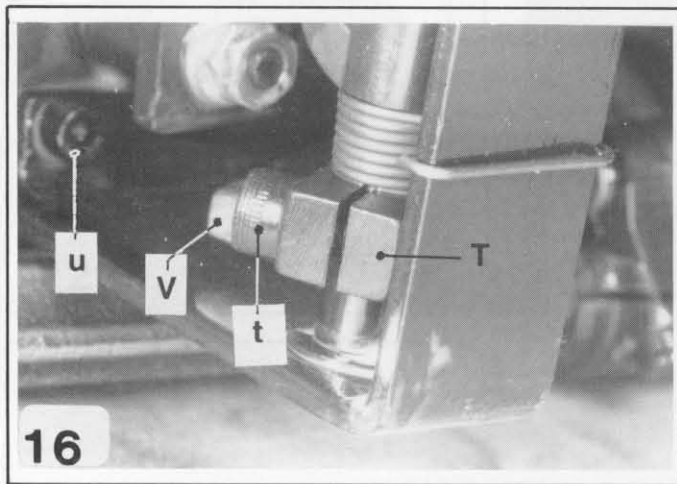
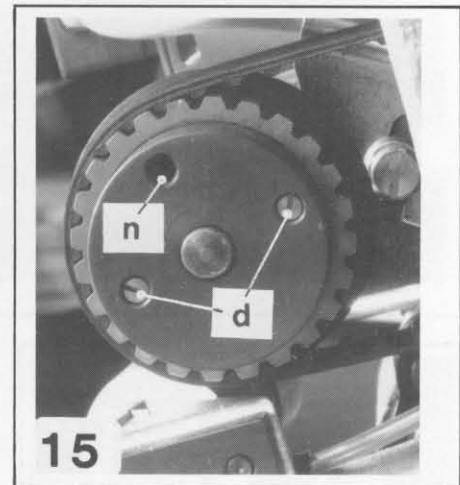
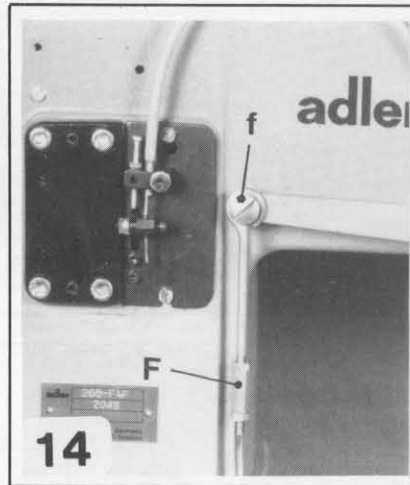
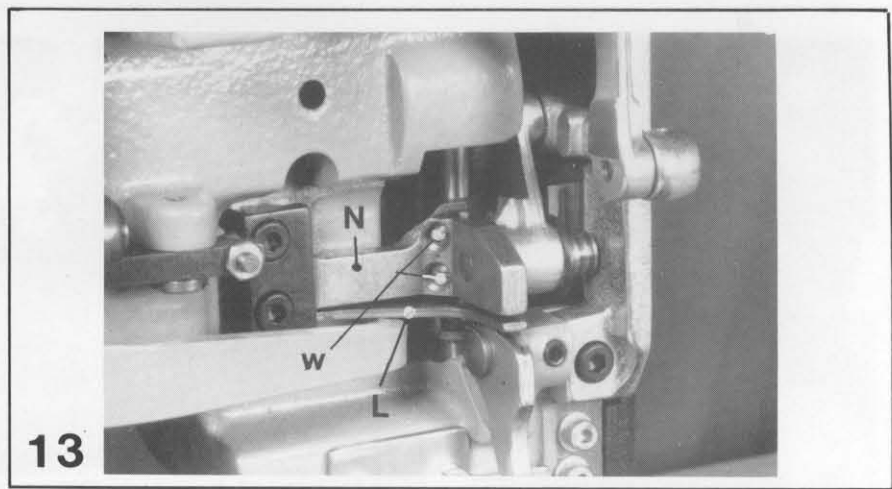
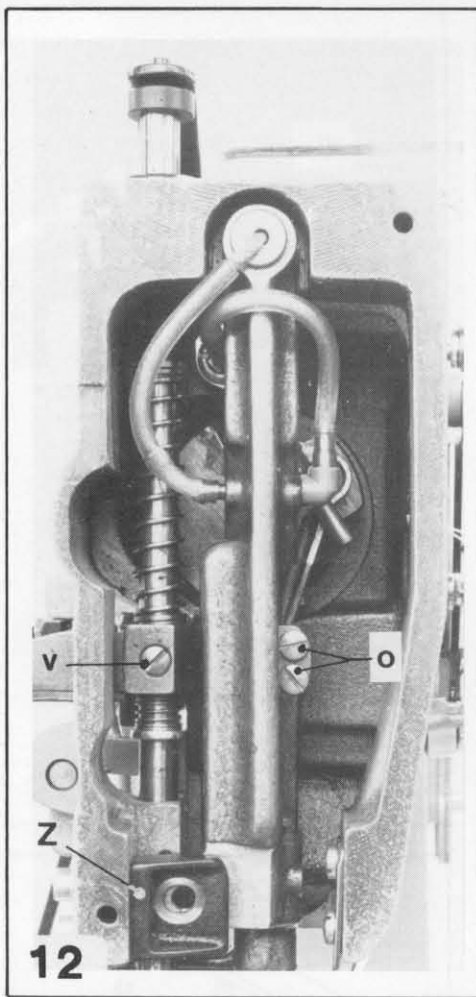

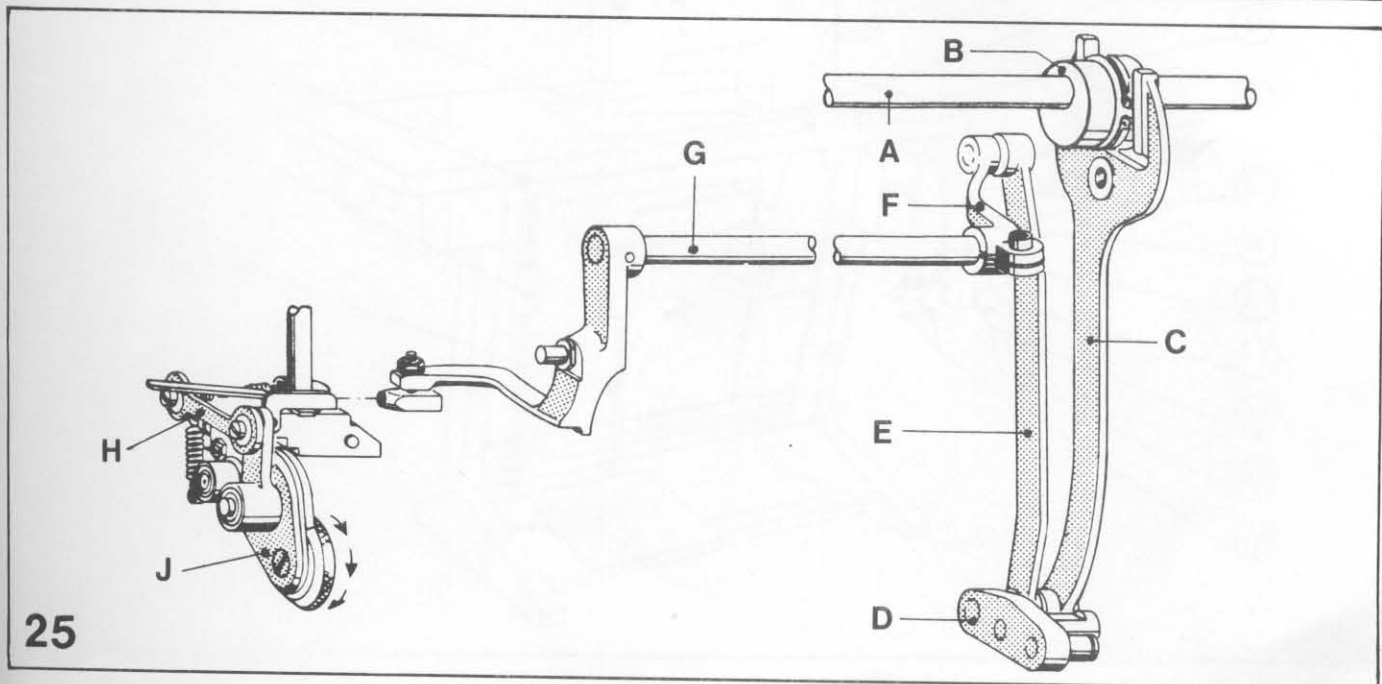
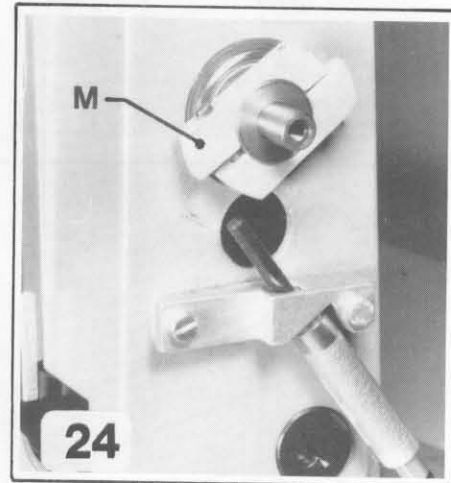
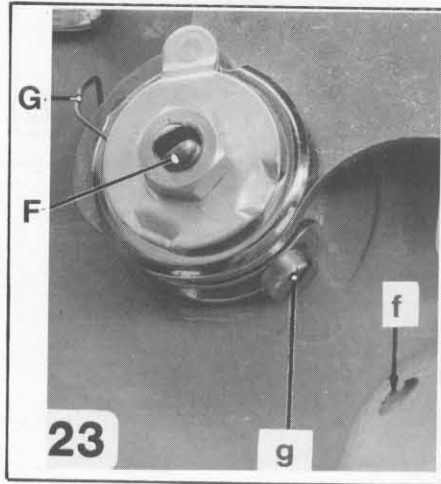
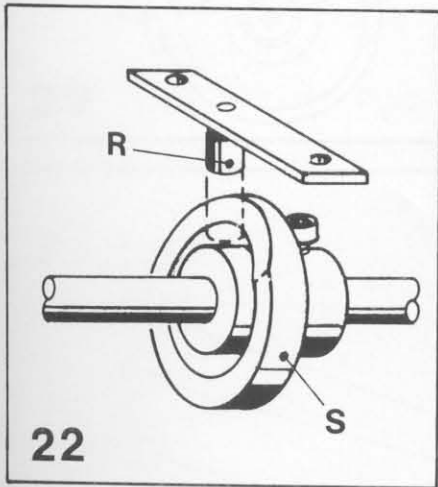
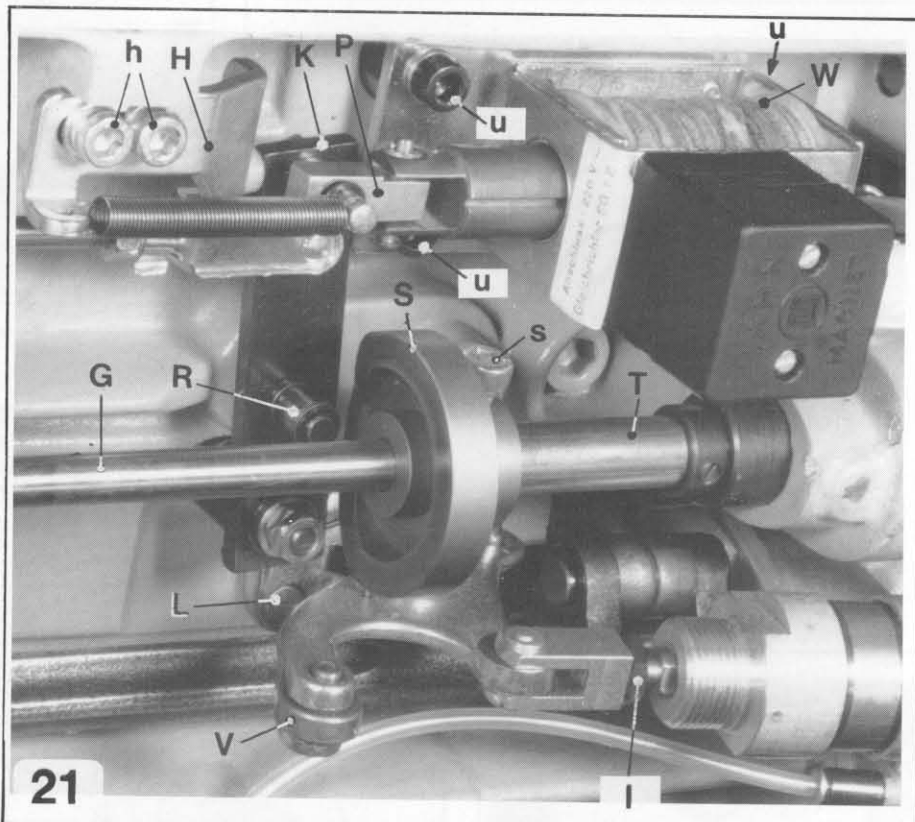
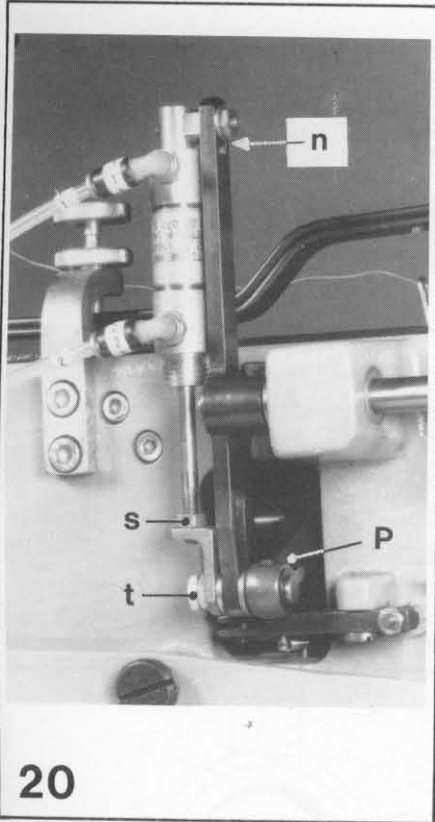

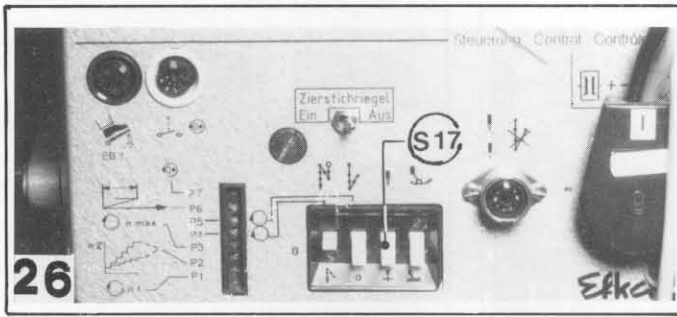

26

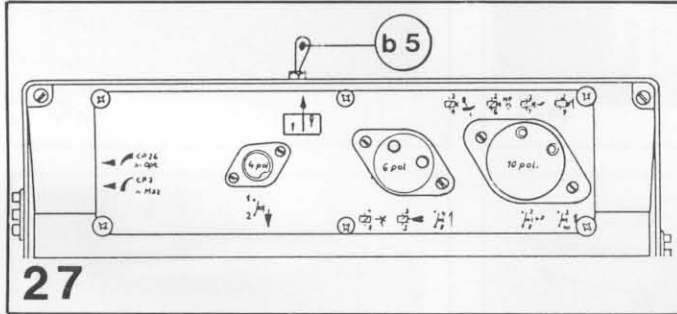

27

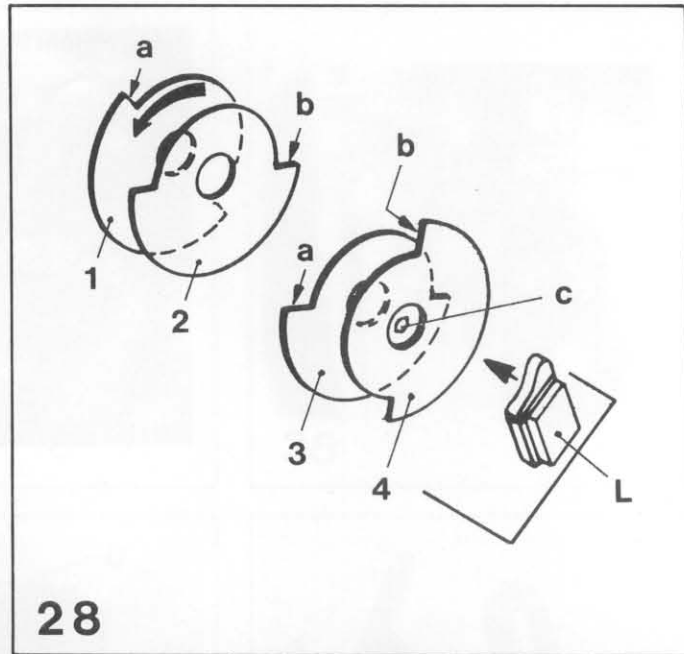

28

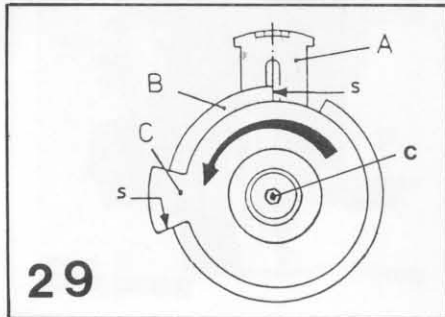

29

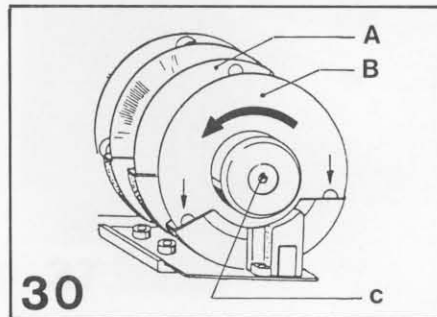

30

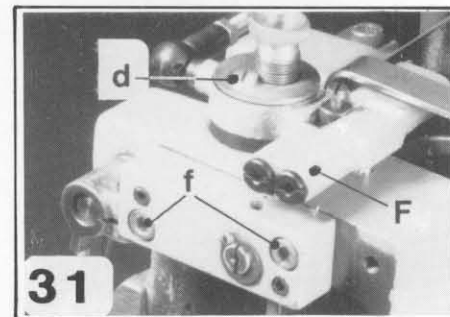

31

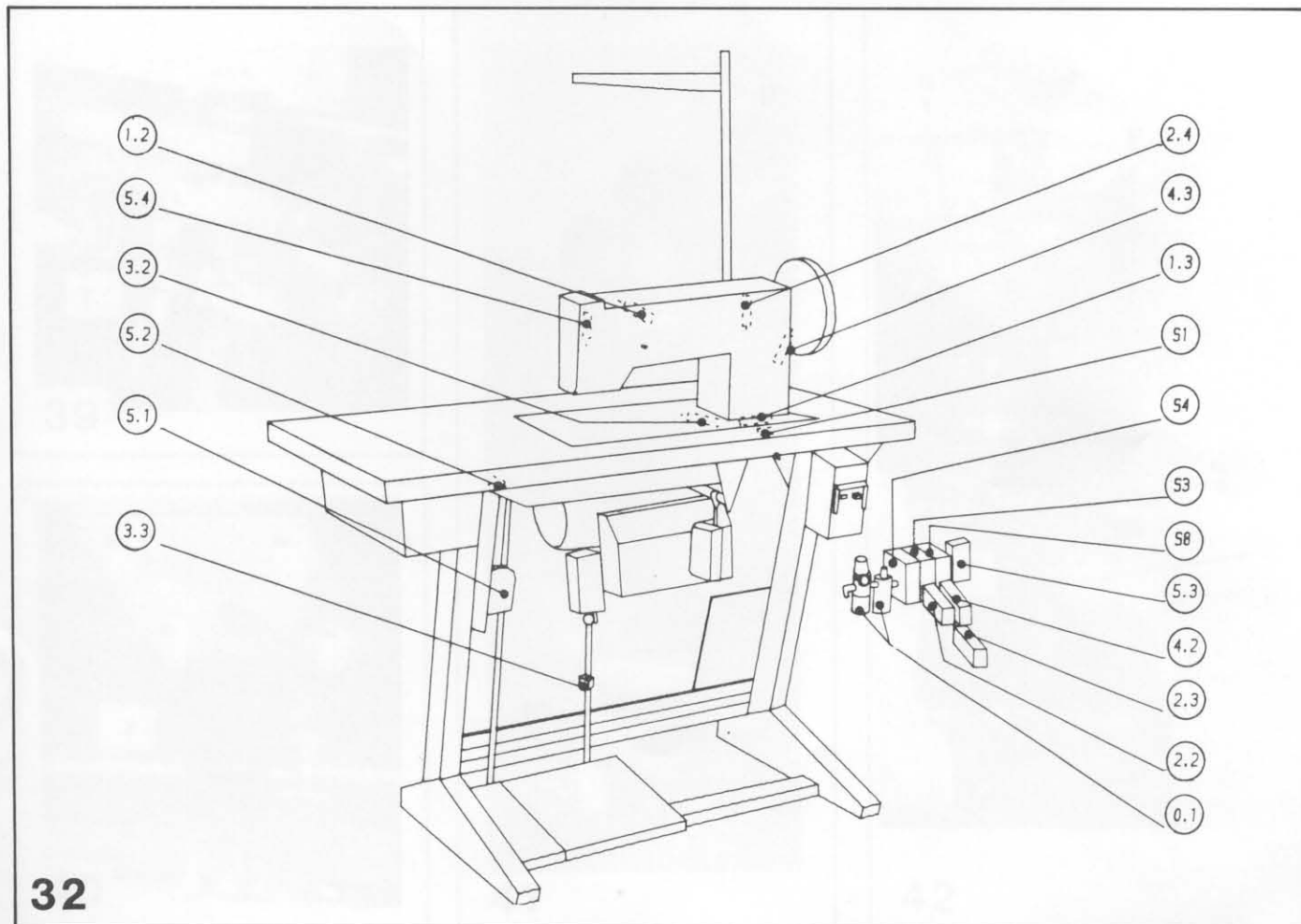

32

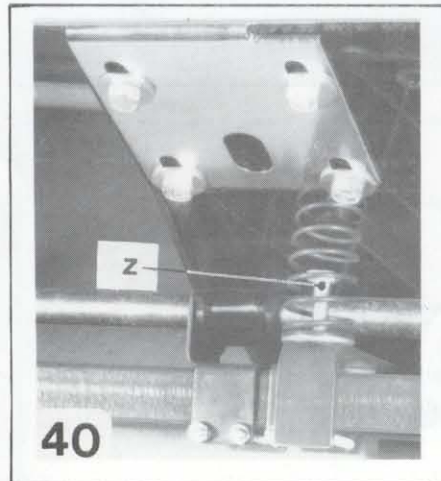
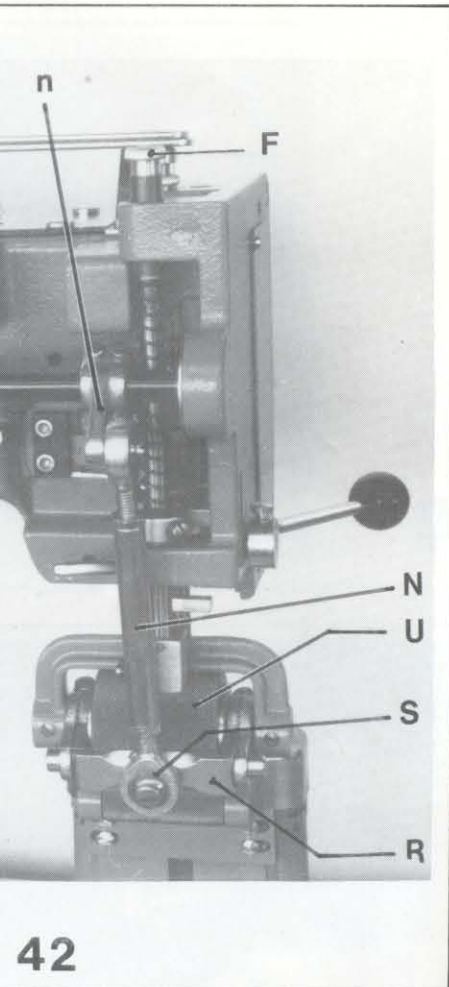
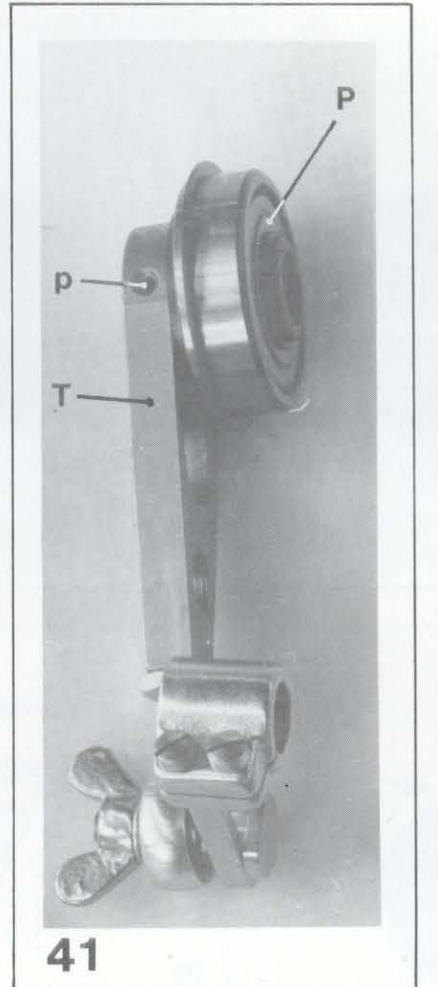
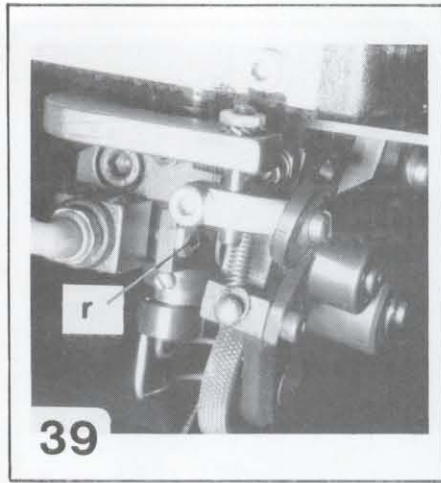
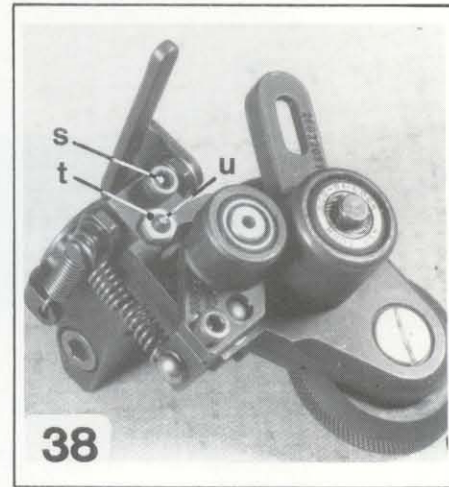
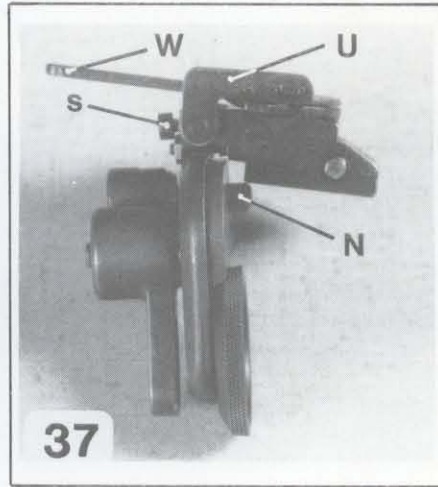
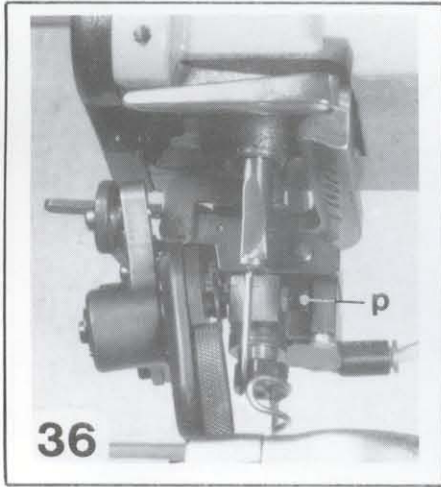
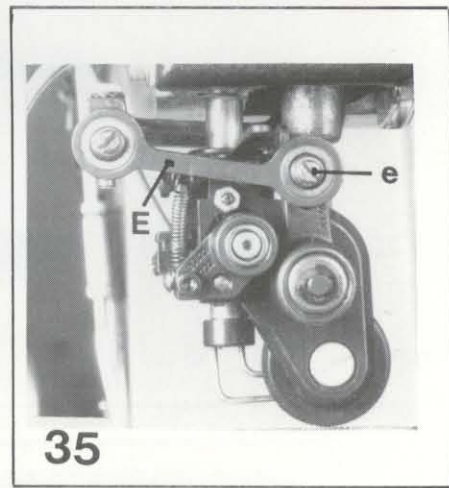
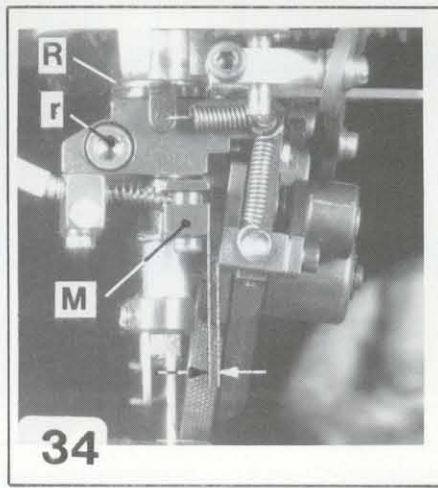
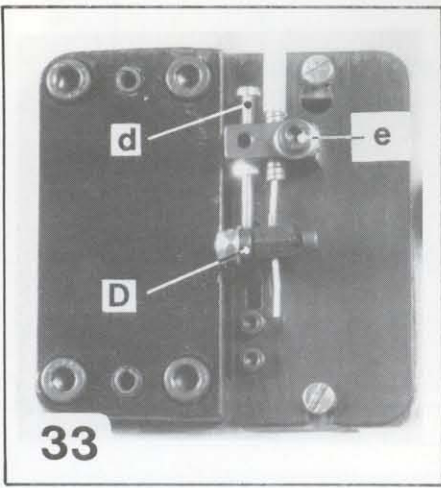

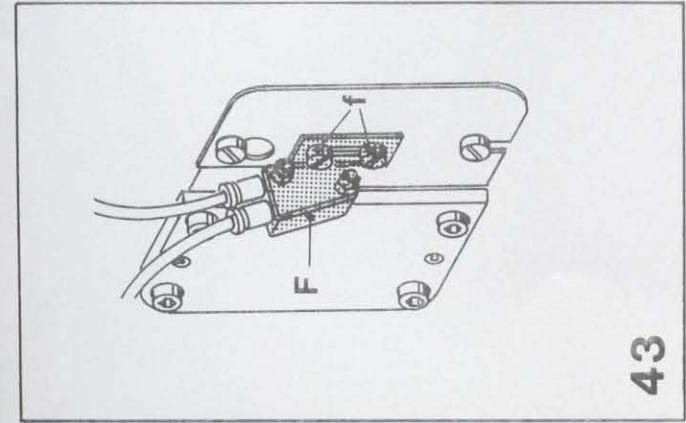

43

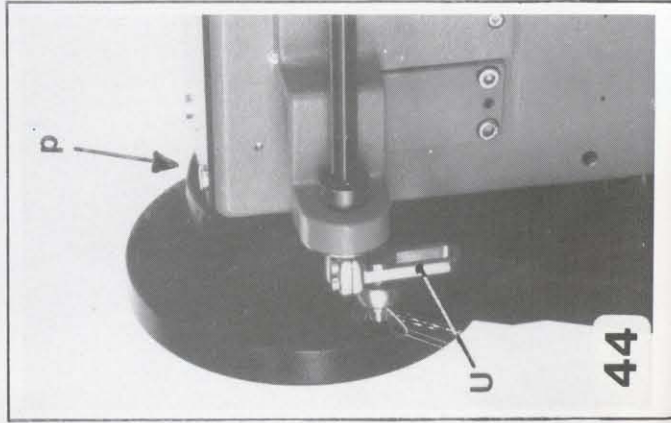

44

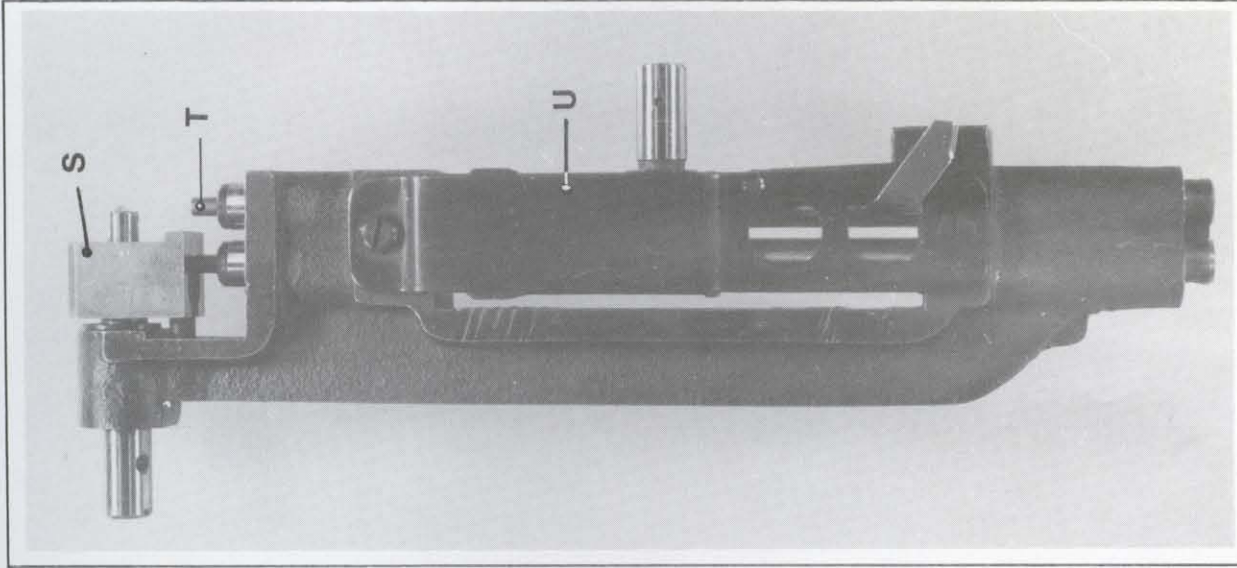

45

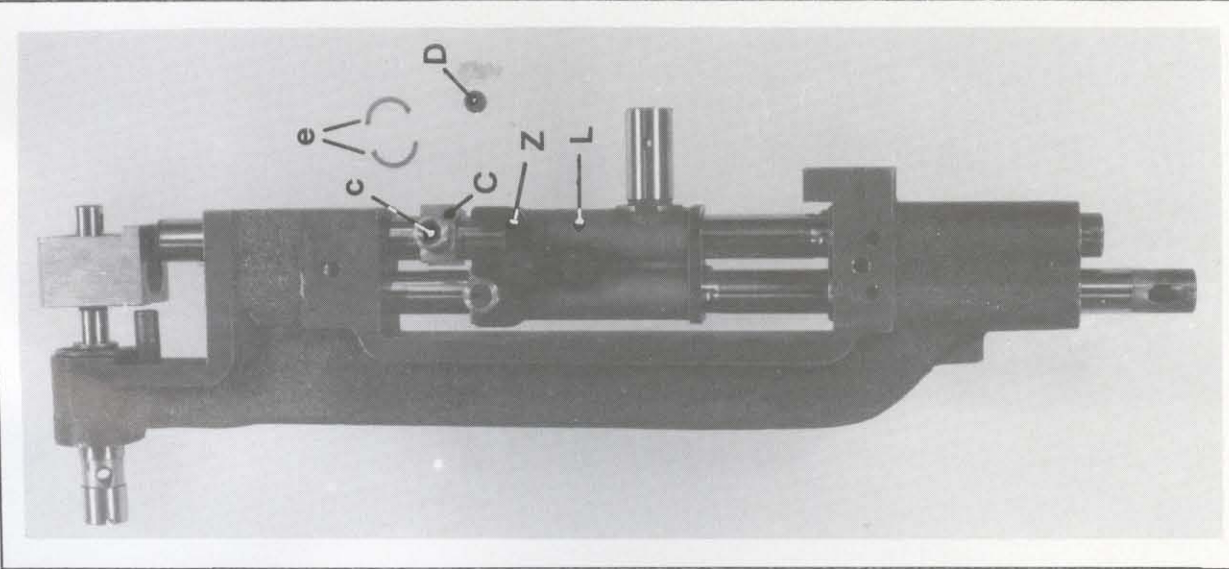

46

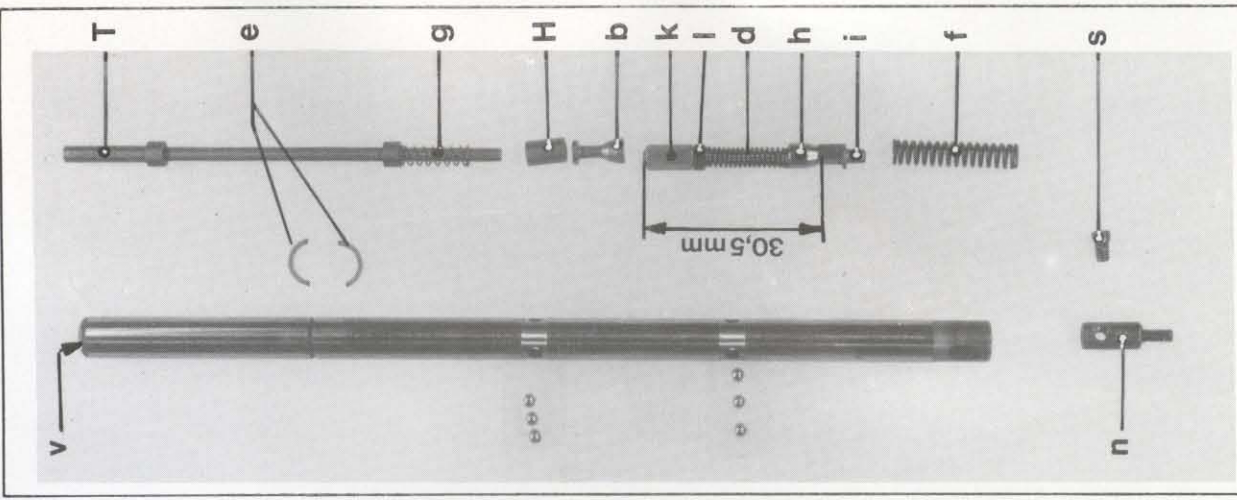

47