

650-10

Operating Instructions



IMPORTANT
READ CAREFULLY BEFORE USE
KEEP FOR FUTURE REFERENCE

All rights reserved.

Property of Dürkopp Adler GmbH and protected by copyright.
Any reuse of these contents, including extracts, is prohibited without the
prior written approval of Dürkopp Adler GmbH.

Copyright © Dürkopp Adler GmbH 2023

1	About these instructions	5
1.1	For whom are these instructions intended?	5
1.2	Representation conventions – symbols and characters	6
1.3	Other documents	7
1.4	Liability	8
2	Safety	9
2.1	Basic safety instructions	9
2.2	Signal words and symbols used in warnings	10
3	Machine description	15
3.1	Components of the machine	15
3.2	Proper use	16
3.3	Declaration of Conformity	17
4	Operation	19
4.1	Preparing the machine for operation	19
4.2	Switching on and off the machine	20
4.3	Changing the needle	21
4.4	Threading the needle thread	22
4.5	Winding the hook thread	24
4.6	Replacing the bobbin	25
4.7	Thread tension	27
4.7.1	Setting the needle thread tension	28
4.7.2	Setting the hook thread tension	29
4.8	Setting the needle thread regulator	31
4.9	Lifting the sewing feet	32
4.10	Functions of the optional additional pedal	33
4.11	Knee lever	34
4.12	Sewing	35
5	Programming (OP3000)	37
5.1	Basic operation	37
5.2	control operating modes	40
5.3	Manual mode	41
5.3.1	Quick access function (softkey menu)	43
5.3.2	Menu for other settings	45
5.3.3	Sewing process	46
5.4	Automatic mode	47
5.4.1	Sewing	49
5.4.2	Cancel sewing program	51
5.5	Easy mode	51
5.5.1	Creating a program by keyboard input	54
5.5.2	Creating a program by sewing the seam	55

5.6	Edit mode	56
5.6.1	Edit the sewing program.....	56
5.6.2	Creating a new sewing program.....	59
5.6.3	Copying the sewing program.....	61
5.6.4	Deleting the sewing program.....	62
5.6.5	Mirroring the sewing program.....	63
5.7	Displaying the software version.....	63
5.8	Service mode	64
5.9	Update machine software.....	64
6	Programming (OP7000)	67
6.1	Control panel OP7000	67
6.1.1	Entering numeric values	68
6.1.2	Entering text	70
6.2	control operating modes	72
6.3	Manual mode MAN.....	73
6.3.1	Parameters that can be set	74
6.3.2	Sewing process	78
6.4	Automatic mode AUTO	79
6.4.1	Parameters that can be set	80
6.4.2	Sewing process	86
6.5	Programming mode EDIT.....	88
6.5.1	Parameters that can be set	89
6.5.2	Creating a new sewing program (PROGRAMMING)	94
6.5.3	Copying the sewing program.....	103
6.5.4	Deleting the sewing program.....	103
6.5.5	Length correction (LENGTH CORRECTION).....	104
6.6	Displaying the software version.....	106
6.7	Operating mode SERVICE.....	106
6.8	Update machine software.....	106
7	Maintenance	113
7.1	Cleaning	114
7.2	Lubricating.....	116
7.3	Parts list.....	117
8	Setup	119
8.1	Check the scope of delivery	119
8.2	Removing the transport locks	119
8.3	Assembling the stand	120
8.4	Pre-assembling the tabletop.....	121
8.5	Completing the tabletop	122
8.6	Attaching the tabletop and pedals to the stand	123
8.7	Setting the working height	124
8.8	Inserting the machine head	126

8.9	Electrical connection	127
8.9.1	Connecting the cables to the machine head	127
8.9.2	Connecting the LED sewing lamp	128
8.9.3	Connecting the setpoint device to the control	129
8.9.4	Establishing equipotential bonding.....	129
8.9.5	Connecting the knee lever.....	130
8.9.6	Connecting the control panel.....	131
8.10	Carrying out a test run	133
9	Decommissioning	135
10	Disposal	137
11	Troubleshooting	139
11.1	Customer Service	139
11.2	Messages of the software	140
11.3	Errors in sewing process	157
12	Technical data	161
12.1	Data and parameters.....	162
12.2	Requirements for trouble-free operation	162
13	Appendix	163
13.1	Tabletop dimensions	163
13.2	Wiring diagram	167

1 About these instructions



These instructions have been prepared with utmost care. They contain information and notes intended to ensure long-term and reliable operation.

Should you notice any discrepancies or if you have improvement requests, then we would be glad to receive your feedback through **Customer Service** ( p. 139).

Consider the instructions part of the product and store them in a place where they are readily available.

1.1 For whom are these instructions intended?

These instructions are intended for:

- **Operators:**
This group is familiar with the machine and has access to the instructions. Specifically, chapter **Operation** ( p. 19) is important for the operators.
- **Specialists:**
This group has the appropriate technical training for performing maintenance or repairing malfunctions. Specifically, the chapter **Setup** ( p. 119) is important for specialists.

Service Instructions are supplied separately.

With regard to minimum qualification and other requirements to be met by personnel, please also follow the chapter **Safety** ( p. 9).

1.2 Representation conventions – symbols and characters

Various information in these instructions is represented or highlighted by the following characters in order to facilitate easy and quick understanding:



Proper setting

Specifies proper setting.



Disturbances

Specifies the disturbances that can occur from an incorrect setting.



Cover

Specifies which covers must be disassembled in order to access the components to be set.



Steps to be performed when operating the machine (sewing and equipping)



Steps to be performed for service, maintenance, and installation



Steps to be performed via the software control panel

The individual steps are numbered:

1. First step
 2. Second step
 - ...
- The steps must always be followed in the specified order.
- Lists are marked by bullet points.



Result of performing an operation

Change to the machine or on the display/control panel.



Important

Special attention must be paid to this point when performing a step.



Information

Additional information, e.g. on alternative operating options.



Order

Specifies the work to be performed before or after a setting.

References



Reference to another section in these instructions.

Safety

Important warnings for the user of the machine are specifically marked. Since safety is of particular importance, hazard symbols, levels of danger and their signal words are described separately in the chapter **Safety** ( p. 9).

Location information

If no other clear location information is used in a figure, indications of **right** or **left** are always from the user's point of view.

1.3 Other documents

The machine includes components from other manufacturers. Each manufacturer has performed a hazard assessment for these purchased parts and confirmed their design compliance with applicable European and national regulations. The proper use of the built-in components is described in the corresponding manufacturer's instructions.

1.4 Liability

All information and notes in these instructions have been compiled in accordance with the latest technology and the applicable standards and regulations.

Dürkopp Adler cannot be held liable for any damage resulting from:

- Breakage and damage during transport
- Failure to observe these instructions
- Improper use
- Unauthorized modifications to the machine
- Use of untrained personnel
- Use of unapproved parts

Transport

Dürkopp Adler cannot be held liable for breakage and transport damages. Inspect the delivery immediately upon receiving it. Report any damage to the last transport manager. This also applies if the packaging is not damaged.

Leave machines, equipment and packaging material in the condition in which they were found when the damage was discovered. This will ensure any claims against the transport company.

Report all other complaints to Dürkopp Adler immediately after receiving the product.

2 Safety

This chapter contains basic information for your safety. Read the instructions carefully before setting up or operating the machine. Make sure to follow the information included in the safety instructions. Failure to do so can result in serious injury and property damage.



2.1 Basic safety instructions

The machine may only be used as described in these instructions.

The instructions should be available at the machine's location at all times.

Work on live components and equipment is prohibited. Exceptions are defined in the DIN VDE 0105.

For the following work, switch off the machine at the main switch or disconnect the power plug:

- Replacing the needle or other sewing tools
- Leaving the workstation
- Performing maintenance work and repairs
- Threading

Missing or faulty parts could impair safety and damage the machine. Only use original parts from the manufacturer.

Transport Use a lifting carriage or forklift to transport the machine. Raise the machine max. 20 mm and secure it to prevent it from slipping off.

Setup The connecting cable must have a power plug approved in the relevant country. The power plug may only be assembled to the power cable by qualified specialists.

Obligations of the operator Follow the country-specific safety and accident prevention regulations and the legal regulations concerning industrial safety and the protection of the environment.

All the warnings and safety signs on the machine must always be in legible condition. Do not remove!
Missing or damaged warnings and safety signs must be replaced immediately.

Requirements to be met by the personnel

Only qualified specialists may:

- set up the machine / put the machine in operation
- perform maintenance work and repairs
- perform work on electrical equipment

Only authorized persons may work on the machine and must first have understood these instructions.

Operation

Check the machine during operating for any externally visible damage. Stop working if you notice any changes to the machine. Report any changes to your supervisor. Do not use a damaged machine any further.

Safety equipment

Safety equipment should not be removed or deactivated. If it is essential to remove or deactivate safety equipment for a repair operation, it must be assembled and put back into operation immediately afterward.

2.2 Signal words and symbols used in warnings





Warnings in the text are distinguished by color bars. The color scheme is based on the severity of the danger. Signal words indicate the severity of the danger.

Signal words Signal words and the hazard they describe:

Signal word	Meaning
DANGER	(with hazard symbol) If ignored, fatal or serious injury will result
WARNING	(with hazard symbol) If ignored, fatal or serious injury can result

CAUTION	(with hazard symbol) If ignored, moderate or minor injury can result
CAUTION	(with hazard symbol) If ignored, environmental damage can result
NOTICE	(without hazard symbol) If ignored, property damage can result

Symbols The following symbols indicate the type of danger to personnel:

Symbol	Type of danger
	General
	Electric shock
	Puncture
	Crushing
	Environmental damage

Examples Examples of the layout of warnings in the text:

DANGER



Type and source of danger!
Consequences of non-compliance.
Measures for avoiding the danger.

↪ This is what a warning looks like for a hazard that will result in serious injury or even death if ignored.

WARNING



Type and source of danger!
Consequences of non-compliance.
Measures for avoiding the danger.

↪ This is what a warning looks like for a hazard that could result in serious or even fatal injury if ignored.

CAUTION



Type and source of danger!
Consequences of non-compliance.
Measures for avoiding the danger.

↪ This is what a warning looks like for a hazard that could result in moderate or minor injury if the warning is ignored.

NOTICE

Type and source of danger!

Consequences of non-compliance.

Measures for avoiding the danger.

- ↪ This is what a warning looks like for a hazard that could result in property damage if ignored.

CAUTION



Type and source of danger!

Consequences of non-compliance.

Measures for avoiding the danger.

- ↪ This is what a warning looks like for a hazard that could result in environmental damage if ignored.

3 Machine description

3.1 Components of the machine

Fig. 1: Components of the machine

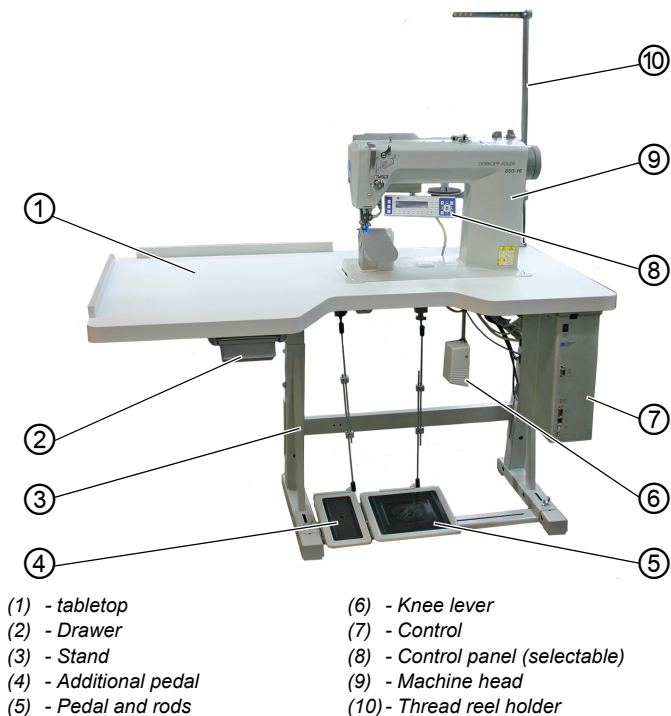

3.2 Proper use

WARNING



Risk of injury from live, moving and cutting parts as well as from sharp parts!

Improper use can result in electric shock, crushing, cutting and punctures.

Follow all instructions provided.

NOTICE

Non-observance will lead to property damage!

Improper use can result in material damage at the machine.

Follow all instructions provided.

The machine may only be used with sewing material that satisfies the requirements of the specific application at hand.

The machine is intended only for use with dry sewing material. The sewing material must not contain any hard objects.

The needle thicknesses permissible for the machine are listed in the **Technical data** ( S. 161) chapter.

The seam must be completed with a thread that satisfies the requirements of the specific application at hand.

The machine is intended for industrial use.

The machine may only be set up and operated in dry conditions on well-maintained premises. If the machine is operated on premises that are not dry and well-maintained, then further measures may be required which must be compatible with DIN EN 60204-31.

Only authorized persons may work on the machine.

Dürkopp Adler cannot be held liable for damages resulting from improper use.

3.3 Declaration of Conformity

The machine complies with European regulations ensuring health, safety, and environmental protection as specified in the declaration of conformity or in the declaration of incorporation.



4 Operation

4.1 Preparing the machine for operation

WARNING



Risk of injury from moving parts, cutting and sharp parts!

Crushing, cutting and punctures are possible.

If possible, make preparations only when the machine is switched off.

Complete the following steps in preparation of sewing before starting to work:

- Changing the needle
- Threading the needle thread
- Threading the looper thread

4.2 Switching on and off the machine

The machine is switched on and off by pressing the main switch (1) on the control.

Fig. 2: Switching on and off the machine

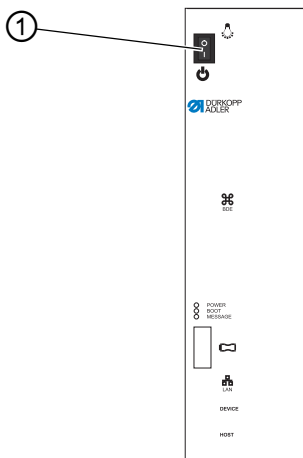

(1) - Main switch



To switch on the machine:

1. Press the main switch (1) down to position I.
- ↳ POWER LED illuminates, MESSAGE LED flashes briefly. The splash screen appears on the display:
 - On the left, the control panel firmware
 - On the right, the control software version
- ↳ The machine performs a reference run and is ready for sewing when the display shows the start screen.



To switch off the machine:

1. Press the main switch (1) up to position 0.
- ↳ The control panel shuts down. When the POWER LED goes out, the machine and the control are disconnected from the power supply.

4.3 Changing the needle

CAUTION



Risk of injury from sharp parts!

Punctures possible.

Switch off the machine before changing the needle.

Fig. 3: Changing the needle

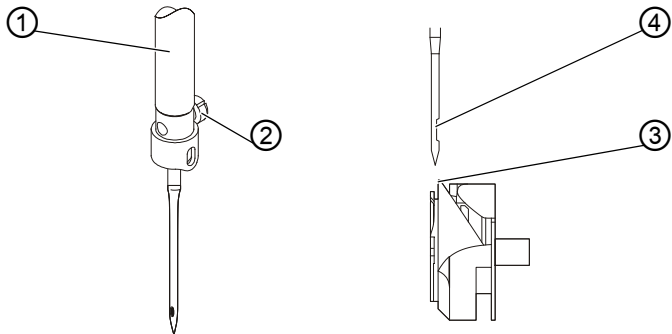

(1) - Needle bar
(2) - Screw

(3) - Hook tip
(4) - Groove



To change the needle:

1. Loosen the screw (2) and remove the needle.
2. Insert the new needle into the hole in the needle bar (1) until it reaches the end stop.



Important

The groove (4) must face towards the hook tip (3).

3. Tighten the screw (2).



Sequence

After changing to a different needle thickness, always adjust the clearance between the hook and the needle (📖 *Service Instructions*).



Disturbance

An incorrect hook distance can cause the following disturbances:

- Changing to a thinner needle:
 - Missing stitches
 - Thread damage
- Changing to a thicker needle:
 - Damage to the hook tip
 - Damage to the needle

4.4 Threading the needle thread

CAUTION



Risk of injuries from cutting parts!

Punctures possible.

Switch off the machine before threading the needle thread.

Fig. 4: Threading the needle thread

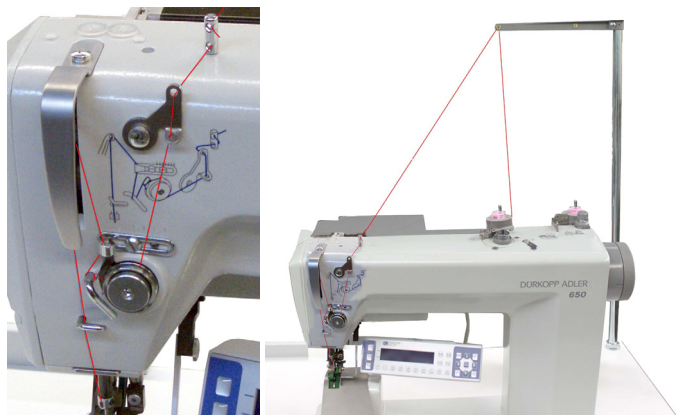



To thread the needle thread:

1. Plug the thread reels on to the thread reel holders and feed the needle and hook threads through the unwinding bracket.



Important

The unwinding bracket must be horizontal and be positioned above the thread reels.

2. Thread the needle thread as shown above.

Threading the needle thread for threads with high elasticity

Fig. 5: Threading the needle thread for threads with high elasticity

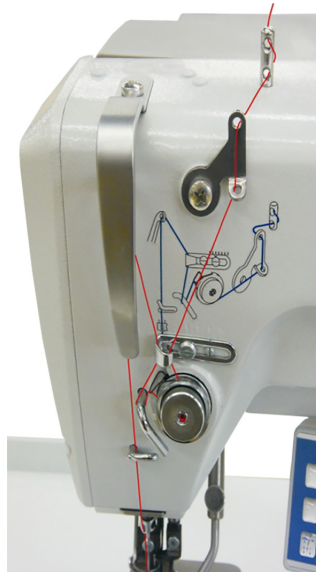

To thread the needle thread when using threads with high elasticity:

1. Thread the needle thread as shown above.

4.5 Winding the hook thread

NOTICE

Property damage may occur!

Moving the bobbin without performing sewing can cause damage to the presser foot and the bobbin case in the hook.

Activate bobbin mode if you wish to wind the hook thread without performing sewing.

Fig. 6: Winding the hook thread

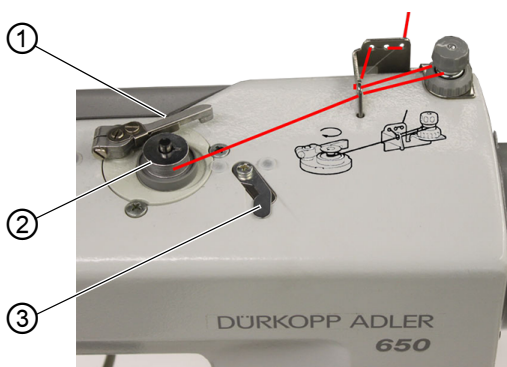



(1) - Winder flap
(2) - Bobbin

(3) - Cutter



To wind the hook thread:

1. Fit the bobbin (2) on the bobbin shaft.
2. Thread the hook thread as shown in the figure.
3. Wind the hook thread clockwise on to the bobbin core.
4. Swing the bobbin winder flap (1) against the bobbin (2).
5. Switch on the machine.
6. Start sewing ( p. 35).
7. The bobbin winder stops automatically when the configured bobbin filling length has been reached ( *Service Instructions*).
8. Pull off the bobbin, clamp the thread under the cutter (3) and tear it off.

4.6 Replacing the bobbin

CAUTION



Risk of injury from sharp and moving parts!

Cutting or crushing possible.

Switch off the machine before replacing the bobbin.

Fig. 7: Replacing the bobbin

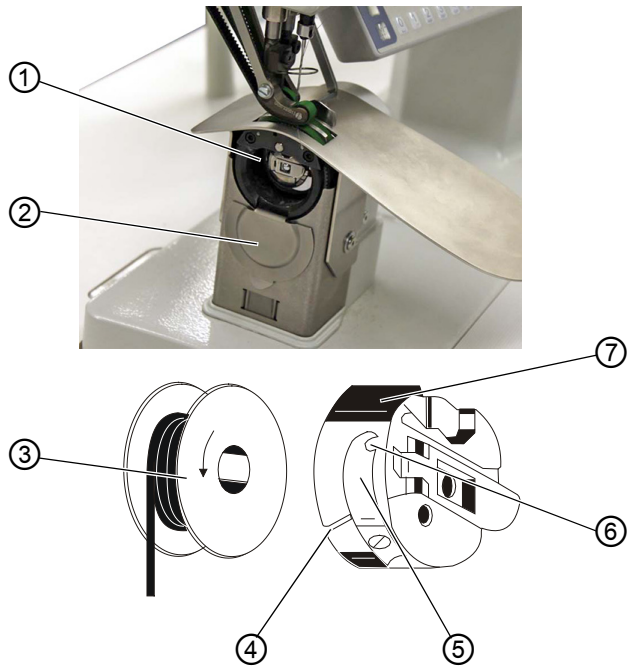

(1) - Bobbin housing flap

(2) - Hook cover

(3) - Bobbin

(4) - Slot

(5) - Tension spring

(6) - Hole

(7) - Bobbin housing upper section



To replace the bobbin:

Removing an empty bobbin

1. Push the hook cover (2) downwards.
2. Move the needle to the top dead center.
3. Lift the bobbin case retainer (1).
4. Remove the bobbin case upper section (7) with the bobbin (3).
5. Remove the empty bobbin (3) from the bobbin case upper section (7).

Inserting a full bobbin

1. Insert the full bobbin into the bobbin case upper section (7).
2. Feed the hook thread through the slot (4) under the tensioning spring (5) into the hole (6).
3. Pull the hook thread approx. 5 cm out of the bobbin case (7).
4. The bobbin must rotate in the direction of the arrow when pulling out the thread.
5. Insert the bobbin case (7) again.
6. Push the hook cover (2) upwards.

4.7 Thread tension

Together with the bobbin thread tension, the needle thread tension influences the seam pattern.

The needle thread tension is defined by the pre-tensioner, the main tensioner and the additional tensioner.



Proper Setting

The main tension (1) should be set as low as possible.

The thread interlacing should be exactly in the middle of the material being sewn.

With thin sewn material, excessive thread tension can lead to undesired gathering and thread breakages.

Abb. 8: Thread tension

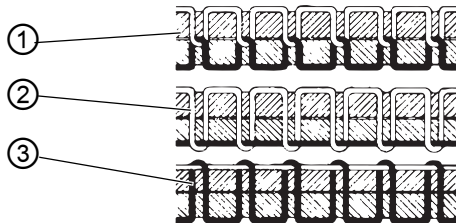

(1) - Identical needle thread and hook thread tension

(2) - Hook thread tension higher than needle thread tension

(3) - Needle thread tension higher than hook thread tension

4.7.1 Setting the needle thread tension

Fig. 9: Setting the needle thread tension

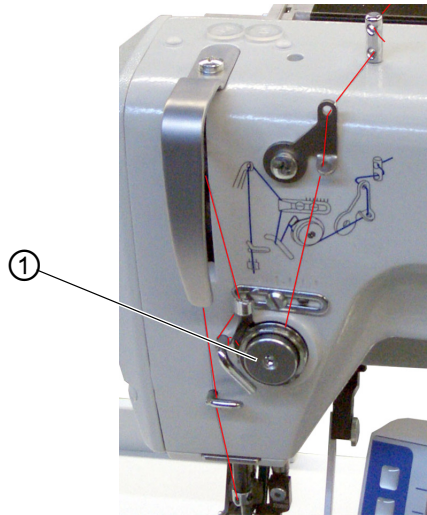

(1) - Main tensioner



To set the needle thread tension:

1. Set the main tensioner (4) via the control panel so that an even stitch pattern is achieved.
When the thread is cut, the main tensioner (4) is opened automatically.

4.7.2 Setting the hook thread tension

CAUTION



Risk of injury from sharp and moving parts!

Cutting or crushing possible.

Switch off the machine before setting the hook thread tension.

Fig. 10: Setting the hook thread tension (1)

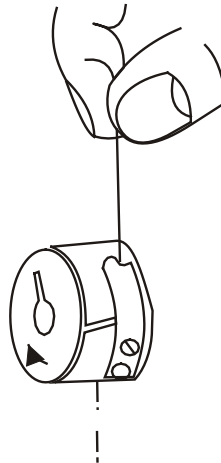

Proper setting

The hook thread tension must be set in such a way that a uniform seam pattern results.

At the recommended hook thread tension of e.g. 25 g (measured with a full bobbin), 12.5 g should be generated by the braking spring and 12.5 g by the tensioning spring.

The basic setting for the tensioning spring is performed as follows:

- When the bobbin case contains a full bobbin it must sink slowly under its own weight.

The braking spring prevents the bobbin running on when the thread has been cut.

Fig. 11: Setting the hook thread tension (2)

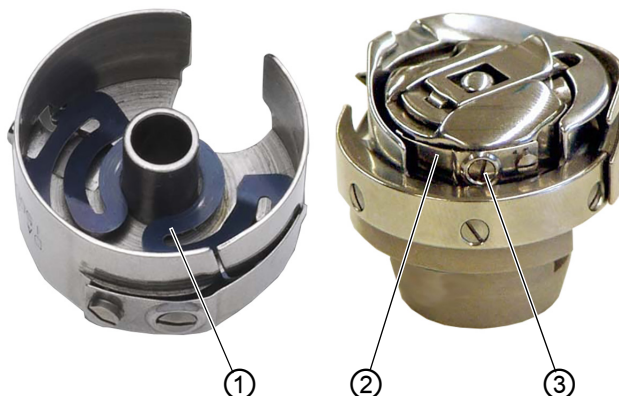

(1) - Braking spring
(2) - Tension spring

(3) - Regulating screw



To set the hook thread tension:

1. Turn back the adjusting screw (3) so far that the tension on the tensioning spring (2) is completely removed.
2. Bend the braking spring (1) such that 50% of the recommended hook thread tension value is applied through the braking spring.
3. Insert the bobbin into the bobbin case upper section and thread in the hook thread (📖 p. 32).
4. Insert the bobbin case together with the bobbin into the hook.
5. Hold the free thread end tightly with one hand.
6. Turn the handwheel until the machine performs one stitch.
7. Pull the hook thread on to the upper side of the needle hole using the needle thread.
8. Remove the hook thread in the direction of sewing at an angle of 45°.
About half the tension value should be evident.
9. Then tighten the adjusting screw (3) up to the recommended tension value.

4.8 Setting the needle thread regulator

The needle thread regulator regulates the amount of needle thread required for forming the stitch. An optimum sewing result is possible only when the needle thread regulator is exactly adjusted.



Proper setting

With the proper setting the needle thread loop must slide over the thickest part of the hook at low tension.

When the largest thread quantity is required then the thread tension spring (3) must be pulled approx. 0.5 mm down from its upper end position. This occurs when the needle thread loop matches the maximum hook diameter.

Fig. 12: Setting the needle thread regulator

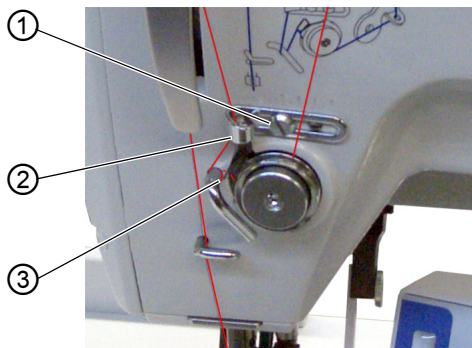

(1) - Screw

(2) - Needle thread regulator

(3) - Thread tensioning spring



To set the needle thread regulator:

1. Loosen the screw (1).
2. Change the setting of the needle thread regulator (2).
3. Tighten the screw (1).

4.9 Lifting the sewing feet

CAUTION



Risk of injury from moving parts!

Crushing possible.

Do not reach under the raised sewing feet.

Fig. 13: Lifting the sewing feet

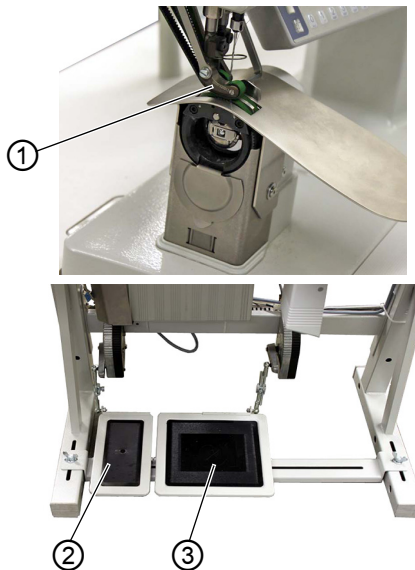

(1) - Sewing feet

(2) - Additional pedal (optional)

(3) - Pedal

The sewing feet (1) can be lifted by pressing the pedal (3) with an electric motor.



To lift the sewing feet:

1. Press the Pedal (3) halfway back.

☞ The sewing feet are lifted.

OR

1. Press the Pedal (3) fully back.
 The thread is cut, and the sewing feet are lifted.

4.10 Functions of the optional additional pedal

The additional pedal (2) has a dual function. Depending on the setting of the technician level it either alters the fullness or the curve support ( *Service Instructions*).

- In automatic mode:
The value for fullness or curve support is corrected for the current step.
- In manual mode:
The value for fullness or curve support is selected.



To use the additional pedal:

1. Press the additional pedal:
 - Press the pedal forwards = increase value.
 - Press the pedal backwards = reduce value

4.11 Knee lever

The knee lever (1) is used to switch the sewing programs from one step to the next, both in Automatic mode and in Edit mode.

Fig. 14: Knee lever



(1) - Knee lever



To use the knee lever:

1. Operate the knee lever (1).
- ↳ The next step is called up.

4.12 Sewing

Before starting sewing	
Initial situation	<ul style="list-style-type: none"> • Pedal in rest position. ↳ Machine is at a standstill. ↳ Needle is up. Sewing foot is down.
Position sewing material at seam beginning	<ul style="list-style-type: none"> • Press the Pedal halfway back. ↳ The sewing feet are raised. • Position the sewing material. • Release the Pedal. ↳ The sewing feet are lowered onto the sewing material.
At seam beginning	
Start bartack and sewing the seam	<ul style="list-style-type: none"> • Push the Pedal forwards and keep it there. ↳ Start bartack is sewn (if specified). Then the machine sews along the seam at the speed determined by the Pedal.
In the middle of the seam	
Stopping sewing	<ul style="list-style-type: none"> • Release the Pedal (position 0). ↳ The machine stops in the 1st position (needle down) or in the needle up position (depending on the setting chosen). The sewing foot is down or raised (depending on the setting chosen).
Continue sewing (after releasing the pedal)	<ul style="list-style-type: none"> • Press the Pedal forwards. ↳ The machine continues to sew at the speed determined by the Pedal.
Intermediate raising	<ul style="list-style-type: none"> • Press the Pedal halfway back. ↳ The sewing feet are raised. • Correct the sewing material. • Release the Pedal. ↳ The sewing feet are lowered.

Altering the fullness	<ul style="list-style-type: none"> • Press fullness key or additional pedal. ↳ The selected fullness value is activated.
At seam end	
Remove the sewing material	<ul style="list-style-type: none"> • Press the Pedal fully back and keep it there. ↳ The end bartack is sewn (if activated). ↳ The threads are cut (if activated). ↳ The machine stops in the 2nd position. ↳ The needle is up. The sewing feet are raised. • Remove the sewing material. • Release the Pedal. ↳ The sewing feet are lowered.

5 Programming (OP3000)

5.1 Basic operation

All settings are performed using the **OP3000** control panel. If your machine is controlled by a different control panel, continue on p. 67.

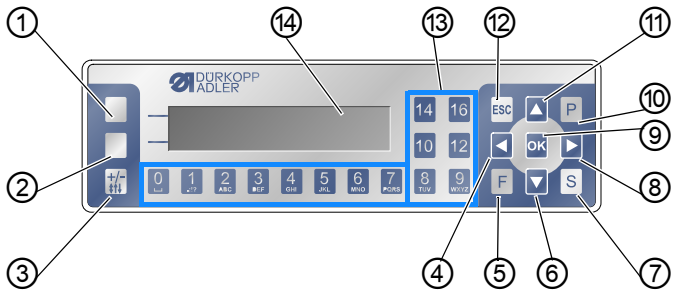

Abb. 15: OP3000



- (1) - Upper Softkey
- (2) - Lower Softkey
- (3) - Plus/Minus key
- (4) - Arrow key
- (5) - F key
- (6) - Arrow key
- (7) - S key
- (8) - Arrow key
- (9) - OK key
- (10) - P key
- (11) - Arrow key
- (12) - ESC key
- (13) - Numeric keys
- (14) - Display

Keys and functions

No.	Key	Function
①	Upper softkey	Assignment is different for each menu
②	Lower softkey	Assignment is different for each menu
③		<ul style="list-style-type: none"> Switch between increase and decrease the fullness Change sign
④		<ul style="list-style-type: none"> Selection to the left Back one menu level
⑤	F	Function is different for each menu

No.	Key	Function
⑥		<ul style="list-style-type: none"> • Decrease the value • Scroll through the list (downwards)
⑦	S	Function is different for each menu
⑧		<ul style="list-style-type: none"> • Selection to the right
⑨	OK	<ul style="list-style-type: none"> • Confirm the settings • Activate the input
⑩	P	<ul style="list-style-type: none"> • Start Edit mode
⑪		<ul style="list-style-type: none"> • Increase the value • Scroll through the list (upwards)
⑫	ESC	<ul style="list-style-type: none"> • Cancel the function • Exit the menu
⑬	0 – 16	<ul style="list-style-type: none"> • Set the fullness • Enter the parameter value (if the field for the parameters is activated) • Select the parameter shown on the display

Display and selection

The display shows menu items and value fields that you can select.

Activated entry

The relevant activated entry is highlighted.

Abb. 16: Activated entry

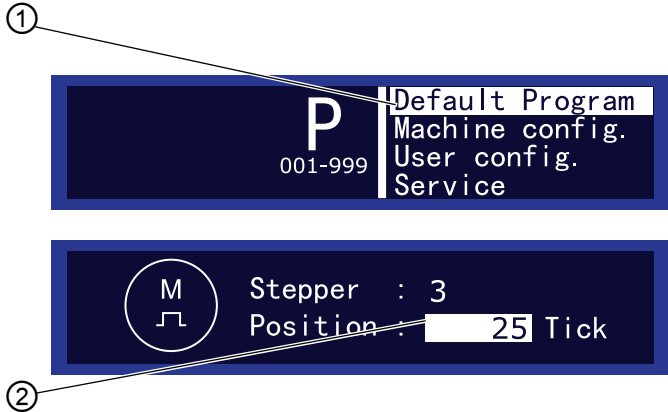

(1) - Activated entry in a menu list (2) - Activated entry in a value field

You can use the arrow keys to move from entry to entry:

- ▲/▼ in a list of menu items
- ◀/▶ for adjacent value fields

Back to menu level

Use ◀ to access the previous menu level.

Canceling in menu lists

If you press **ESC** in a menu list, this will bring you to the user level.

Changing values

In activated value fields, you can enter a value by using the numeric keys or change it incrementally using ▲/▼.

If you have entered a value that is not within the specified value range, the software will automatically adopt from the value range the limit value which is closest to your entry.

Confirm with OK

When pressing **OK**, you apply the activated entry.

When pressing **OK** in a menu list, you open the selected menu item

Canceling value editing

If you press **ESC** when editing value fields, you can cancel the entry without having to apply your changes.

5.2 control operating modes

The control offers 5 different operating modes:

- **Manual mode** ( p. 41)

Manual mode (program number 000) is the simplest operating mode.

In Manual mode, there are no sewing programs and no inputs for individual sewing steps.

Any changes made to parameters are applied immediately during the sewing process.
- **Automatic mode** ( p. 47)

Automatic mode (program number 001 – 999) allows sewing programs to be executed.

The seams are divided into individual sections (steps) within the sewing programs. Each step is assigned its own individual parameters such as fullness, curve support etc.
- **Easy mode** ( p. 51)

Easy mode allows the operator to create new sewing programs in a quick and easy fashion.
- **Edit mode** ( p. 56)

In Edit mode, sewing programs can be created, changed (Edit mode), deleted, copied and mirrored (right or left sleeve).
- **Service mode** ( p. 64)

Service mode contains functions for use during service work.

Service mode is passcode-protected to avoid accidentally changing the machine settings.





5.3 Manual mode







Fig. 17: Manual mode



The following table shows the individual symbols (parameters) on the display and the functions of the keys on the control panel.

When a parameter is selected, its color on the display changes. When a parameter is changed, its new value is loaded immediately.

Symbol	Meaning
	(depending on the assignment) Quick programming • Press the upper softkey (☰ p. 51)
	Quick access function (softkey menu) • Press the lower softkey (☰ p. 43)
	Program number Value range: 000 – 999 Program 000 indicates that the control is in "Manual mode". • Use ◀ / ▶ to select the parameter • Use ▲ / ▼ to change the program number. Or: • Input the program number directly using one of the numeric keys 0 – 9 and confirm with OK as required ↳ The control switches to Automatic mode
	Fullness Value range: Upper fullness: 0 – 16 Lower fullness: 0 – 6 • Use the numeric keys 0 – 16 to select the desired fullness • Use the plus/minus key to select upper or lower fullness Or: • Use the additional pedal to select the fullness, if fitted

Symbol	Meaning
	Stitch length Value range: 1.0 – 4.0 mm • Use ◀ / ▶ to select the parameter • Use ▲ / ▼ to change the stitch length
	Thread tension Value range: 1 – 99 • Use ◀ / ▶ to select the parameter. • Use ▲ / ▼ to change the thread tension
	Curve support Value range: 0 – 6 • Use ◀ / ▶ to select the parameter • Use ▲ / ▼ to change the curve support
	Other parameters (📖 p. 45)
	Seam length in mm After the thread has been cut, the display is retained. Measurement restarts when sewing starts again.
	Switch between upper and lower fullness
ESC, F, S, OK	No function assigned
0 – 16	Fullness values

5.3.1 Quick access function (softkey menu)

Here you have quick access to functions during the sewing process and can also assign a function to the upper softkey.



To open the softkey menu:

1. Press the lower softkey .

↳ The following appears on the display:

Abb. 18: Quick access function (softkey menu)









Selecting a function in the softkey menu



To select a function in the softkey menu:

1. Press the numeric key under the desired function.

Symbol	Meaning
	Manual bartack on <ul style="list-style-type: none"> • Press key 1 and keep it pressed for a manual bartack
	Bartack suppression on or off <ul style="list-style-type: none"> • Press key 2 ↳ The bartacks are switched on or off
	Needle position up or down <ul style="list-style-type: none"> • Press key 3 ↳ The needle is up or down when sewing stops

Symbol	Meaning
	Automatic step progression on or off (available only in Automatic mode) <ul style="list-style-type: none"> • Press key 4. ↳ Automatic step progression is enabled/disabled whilst sewing a seam
	Quick programming <ul style="list-style-type: none"> ↳ Press key 5 Quick programming starts
	Winder mode on or off <ul style="list-style-type: none"> • Press key 6 • Press the Pedal forwards ↳ The hook thread is wound on <ul style="list-style-type: none"> • Press the Pedal halfway back ↳ Winder mode is ended



2. Exit menu using **ESC**.

Assigning a function to the upper softkey









To assign a function to the upper softkey:

1. Press the numeric key under the desired function and the upper softkey at the same time.
 - ↳ The function is assigned to the upper softkey and can be called up by pressing the key.

5.3.2 Menu for other settings



1. Use ◀ / ▶ to select the field .
2. Press the **OK** key.
3. Use ▲ / ▼ to select the desired parameter.
4. Press the **OK** key to select the parameter.
5. Change values using the ▲ / ▼ keys.
6. Press the **OK** key to confirm.
7. Press ◀ or **ESC** to exit the menu.

Symbol	Meaning
	Alternate (sewing foot alternation) Value range: 0.0 – 2.5 mm
	Foot Press. (sewing foot pressure) Value range: 1 – 10
	Start Tack (bartack at seam beginning) Value range: 1 (= on) or 0 (= off)
	End Tack (bartack at seam end) Value range: 1 (= on) or 0 (= off)
	Thread Trim (thread cutter) Value range: 1 (= on) or 0 (= off)

5.3.3 Sewing process

Sewing without fullness



To sew without fullness:

1. Input values for stitch length, thread tension, curve support and foot alternation.
2. Push the pedal forwards and sew.

Sewing with fullness



To sew with fullness:

1. Use the numeric keys **0 – 16** and  to change the fullness.

OR



1. Change the fullness with the additional pedal (optional) (if set at the technician level),  *Service Instructions*.

Altering parameters whilst within the seam



To alter parameters whilst within the seam:

1. Press Pedal to position **0**.
 2. Change the desired parameter on the control panel.
 3. Push the pedal forwards and sew.
- ↳ The seam will be sewn using the altered parameter value.

5.4 Automatic mode



To select the automatic mode:

1. Use ◀ / ▶ to select the field **P**
000.
 2. Use ▲ / ▼ to select the program number 001 or another one (if available).
- ↳ The control switches to Automatic mode and the following information appears on the display:







Fig. 19: Automatic mode



The following table shows the individual symbols on the display and the functions of the keys on the control panel.

Before starting sewing

Symbol	Meaning
	Quick programming (depending on the assignment) • Press the upper softkey
	Quick access function (softkey menu) • Press the lower softkey
P 001	Program number Value range: 000 – 999 • Use ◀ / ▶ to select the parameter • Use ▲ / ▼ to change the program number. OR: • Input the program number using the numeric keys 0 – 9 and confirm with OK as required If you select program 000, the control selects Manual mode.

Symbol	Meaning
	Right sleeve / left sleeve The machine can sew only right sleeves, only left sleeves, or right and left sleeves alternately. <ul style="list-style-type: none"> • Use ▲ / ▼ to select a right sleeve or a left sleeve (if programs exist for both)
	Steps Number of steps contained in the current sewing program.
	Stitch length Value range: 1.0 – 4.0 mm The stitch length can be altered before starting sewing. The altered value applies throughout the entire sewing program. <ul style="list-style-type: none"> • Use ◀ / ▶ to select the parameter • Use ▲ / ▼ to adjust the stitch length
	Thread tension Value range: 1 – 99 The thread tension can be altered before starting sewing. The altered value applies throughout the entire sewing program. <ul style="list-style-type: none"> • Use ◀ / ▶ to select the parameter • Use ▲ / ▼ to change the thread tension
	Other parameters Foot Press. (sewing foot pressure) Fulln.Corr. (fullness correction) <ul style="list-style-type: none"> • Use ◀ / ▶ to select the parameter • Press the OK key. • Use ▲ / ▼ to select the fullness correction or the sewing foot pressure. • Select the parameter using the OK key • Change values using ▲ / ▼ . • Press the OK key to confirm. • Press ◀ or ESC to exit the menu.
Program bar Length per step in mm, or a dash (-) if no automatic step progression 	
ESC, F, S	No function assigned

Before you can start the sewing process, you need to switch to the 1st step.



To switch to the 1st step:

1. Sew, press the knee lever or press the **OK** key.
- ↳ The program switches to the 1st step.

5.4.1 Sewing

Start the sewing process as follows:



To sew:

1. Push the pedal forwards and sew.
- ↳ The following appears on the display:

Abb. 20: Sewing (1)

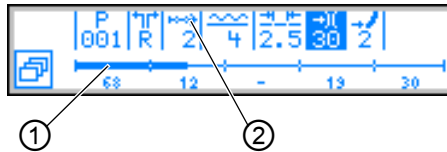

(1) - Program bar

(2) - Current step

The parameter values for the current step are shown on the display.

The program bar (1) shows the progress of the seam.

The number under the current step (3) shows the outstanding length of the step.

The program bar shows half the current step in bold.

Abb. 21: Sewing (2), Current step



Completed steps are shown fully in bold.

Abb. 22: Sewing (3), Completed step



The following table lists the functions that can be performed in the course of the seam.

Key/Pedal	Function
Plus/minus and 0 – 16	Temporary correction of the fullness value (valid only for the current step)
Additional pedal (optional)	Temporary correction of the fullness value or the curve support (depending on the setting in the technician level) (valid only for the current step)
Knee lever	Next program step
◀ / ▶ 3	Stop forward/back or to the start of the step Switch the sleeve side (if programmed) in the 1 st step at the start of the step
▲ / ▼	Correction of the thread tension The value is saved
P, F, S, OK	No function assigned
Press the Pedal halfway back	Lift sewing foot
Press the Pedal fully back	Cut thread The program remains stopped at the cutoff point (does NOT apply to the last step)
Lower softkey	Softkey menu ( p. 41)



5.4.2 Cancel sewing program



To cancel the sewing program:

1. Press the pedal fully back.
 - ↳ The thread is cut.
2. Press the **ESC** key.
 - ↳ The sewing program is canceled.

5.5 Easy mode

Prerequisite: You are in Manual mode ( p. 41) or in Automatic mode ( p. 47).

If  is assigned to the upper softkey:





1. Press the upper softkey .
 - ↳ The following appears on the display:

Fig. 23: Easy mode (1)



2. Continue with step 3.

If  is not assigned to the upper softkey:

1. Press the  key.
- ↳ The softkey menu appears on the display:

Fig. 24: Easy mode (2)



2. Press key 5.
3. Press **OK** to load the program number.

OR



Select another program number using $\blacktriangle/\blacktriangledown$ or input a program number using the keypad keys **0 – 9** and then press the **OK** key.



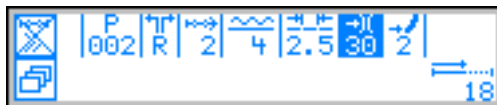



- ↳ The display shows the following information, the **P** in the program number field flashes:

Fig. 25: Easy mode (3)



The following table shows the individual symbols on the display and the functions of the keys on the control panel.

Symbol	Meaning
	Automatic step progression on or off • Press the upper softkey
	Current sewing program to be created
	Current sleeve side to be created (pre-set at the technician level)

Symbol	Meaning
	<p>Current step</p> <ul style="list-style-type: none"> • Use ◀ / ▶ to select the parameter • Use ▲ / ▼ to switch to the next/previous step • Press the OK key to edit other parameters for the step, Edit mode (📖 p. 56)
	<p>Fullness</p> <p>Value range: Upper fullness: 0 – 16 Lower fullness: 0 – 6</p> <ul style="list-style-type: none"> • Use the numeric keys 0 – 16 to select the desired fullness. • Use the plus/minus key to select upper or lower fullness. <p>OR:</p> <ul style="list-style-type: none"> • Use the additional pedal to select the fullness, if fitted
	<p>Stitch length</p> <p>Value range: 1.0 – 4.0 mm</p> <ul style="list-style-type: none"> • Use ◀ / ▶ to select the parameter • Use ▲ / ▼ to change the stitch length
	<p>Thread tension</p> <p>Value range: 1 – 99</p> <ul style="list-style-type: none"> • Use ◀ / ▶ to select the parameter • Use ▲ / ▼ to change the thread tension
	<p>Curve support</p> <p>Value range: 0 – 6</p> <ul style="list-style-type: none"> • Use ◀ / ▶ to select the parameter • Use ▲ / ▼ to change the curve support
	<p>Length of the current step in mm</p>

5.5.1 Creating a program by keyboard input



Information

Before the **S** key is pressed, program creation can be canceled at any time by pressing the **ESC** key.



To create a program by keyboard input:

1. Set all the parameters for each step.



2. Operate the knee lever.

↳ The control switches to the next step.

Once all steps are complete:



3. Press the **S** key.

↳ The sewing program is saved.

Depending on the settings at the technician level

- The sleeve side that was created is mirrored
- The sleeve side that was created is not mirrored
- The teach-in for the 2nd sleeve side is opened
- The selection screen for the action of creating the 2nd sleeve side is opened

↳ The control switches to Automatic mode.

The sewing program that was just created is activated.

Fig. 26: Creating a program by keyboard input

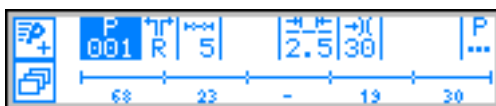

5.5.2 Creating a program by sewing the seam



Information

Before the **S** key is pressed, program creation can be canceled at any time by pressing the **ESC** key.

If a section of seam has already been sewn the sewing program will have been saved and must if necessary be deleted, ( p. 62).



To create a program by sewing the seam:

1. Insert the sewing material.



2. Input the parameters for the 1st step (fullness, stitch length, thread tension and curve support).



3. Sew the first step.

4. Operate the knee lever.

↳ The control switches to the next step.

Once all steps are complete:



5. Press the **S** key.

↳ The sewing program is saved.

The following appears on the display:

Fig. 27: Creating a program by sewing the seam (1)



6. Sew the overlap.

7. Press the Pedal fully back.

↳ The sleeve that was created is mirrored, depending on the settings at the technician level.

The control switches to Automatic mode.

The sewing program that was just created is activated.

Fig. 28: Creating a program by sewing the seam (2)



5.6 Edit mode

Prerequisite: You are in **Automatic mode** (📖 p. 47).

5.6.1 Edit the sewing program



To edit the sewing program:

1. In Automatic mode, press the **P** key.
 - ↳ The control switches to Edit mode.
The sewing program previously selected can now be edited.
The display shows the following information, the **P** in the program number field flashes:

Fig. 29: Edit the sewing program



2. Use **◀ / ▶** to select the sewing program to be edited, the sleeve side and the step; and use **▲ / ▼** to edit them.



Information

The step to be edited can also be selected using the knee lever.





- ↳ The selected step is shown bold in the program bar.
3. Use **◀ / ▶** to select the parameter to be changed for the respective step, and use **▲ / ▼** to change it.

Changing further parameters for the current step



To change parameters for the current step:

1. Use ◀ / ▶ to select the field  2.
2. Press the **OK** key.
- ↳ The submenu opens.
3. Use ▲ / ▼ to select the desired parameter.
4. Press the **OK** key to activate or deactivate the parameter, or use ▲ / ▼ to change its value and press **OK** to confirm it.

Symbol	Meaning
	Step. Len. (step length)
	Auto Forward (automatic step progression)
	Alternate (sewing foot stroke height)
	Foot Press (sewing foot pressure)



5. Exit the submenu using **ESC** or ◀ .



You can exit Edit mode with a press of the **ESC** key.







Changing further parameters for the selected sewing program

This menu allows further parameters for the current sewing program to be changed.



To change further parameters:

1. Use ◀ / ▶ to select the field  .
2. Press the **OK** key.
 The submenu opens.
3. Use ▲ / ▼ to select the desired parameter.
4. Press the **OK** key to activate or deactivate the parameter, or use ▲ / ▼ to change its value and press **OK** to confirm it.

Symbol	Meaning
	Thr. Tens. (thread tension)
	Stitchlen. (stitch length)
	Foot Press. (sewing foot pressure)
	Fulln. Corr. (fullness correction)
	Start Tack (bartack at seam beginning)
	End Tack (bartack at seam end)
	Thread Trim (thread cutter)



5. Exit the submenu using **ESC** or ◀ .

You can exit Edit mode with a press of the **ESC** key.

5.6.2 Creating a new sewing program



To create a new sewing program:

1. In **Edit mode**, press the  key.
 ↳ The softkey menu appears on the display:

Fig. 30: Creating a new sewing program (1)



2. Press the  key.
 ↳ The display shows the next available program number:

Fig. 31: Creating a new sewing program (2)



3. Press **OK** to load the program number.
OR
 Select another program number using $\blacktriangle/\blacktriangledown$ or input a program number using the keypad keys **0 – 9** and then press the **OK** key.
 ↳ The program number is loaded.
 The display shows the following information, the **P** in the program number field flashes:

Fig. 32: Creating a new sewing program (3)





4. If necessary change the sleeve side or other parameters ( p. 56).

5. Press the  key.

↳ The display shows the following information, the **P** in the program number field flashes:

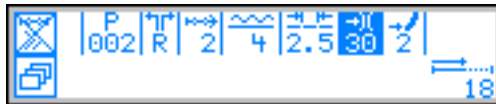
Fig. 33: Creating a new sewing program (4)



The rest of the procedure is described in the chapter **Easy mode** ( p. 51).



6. Select whether progression to the individual steps to be programmed should be by using the knee lever or by automatic progression.

7. Press the  key.

Once the creation of the program is complete and the **S** key has been pressed or after the thread cutoff has been entered, the following selection window appears:

Fig. 34: Creating a new sewing program (5)



8. Press the corresponding key to select if
 - the sleeve side that was programmed should be mirrored
 - the sleeve side that was programmed should not be mirrored
 - the teach-in for the 2nd sleeve side should be opened

5.6.3 Copying the sewing program

The selected sewing program is copied into a new program number.



To copy an existing sewing program:

1. Press the key.

↳ The softkey menu appears on the display:

Fig. 35: Copying the sewing program (1)



2. Press the key.

↳ The display shows the next available program number:

Fig. 36: Copying the sewing program (2)



3. Press **OK** to load the program number.

OR

Select another program number using **▲/▼** or input a program number using the keypad keys **0 – 9** and then press the **OK** key.

↳ The program number is loaded.
The display shows the following information, the **P** in the program number field flashes:

Fig. 37: Copying the sewing program (3)





4. Load the desired changes into the new sewing program.
 5. Press the **ESC** key.
- ↳ The control switches to Edit mode to Automatic mode.

5.6.4 Deleting the sewing program

The selected sewing program is deleted.



To delete an existing sewing program:



1. Press the  key.
- ↳ The softkey menu appears on the display:

Fig. 38: Deleting the sewing program



2. Press the  key.
 3. Press the **ESC** key.
- ↳ The control switches to Edit mode to Automatic mode.

5.6.5 Mirroring the sewing program

The sleeve side already programmed is mirrored over to the other sleeve side.



To mirror a sewing program:



1. Press the  key.
- ↳ The softkey menu appears on the display:

Fig. 39: Mirroring the sewing program



2. Press the  key.
3. Press the **ESC** key.
- ↳ The control switches to Edit mode to Automatic mode.

5.7 Displaying the software version



To display the software version:

1. Switch off and on the machine.
- ↳ The splash screen appears on the display:
 - On the left, the control panel firmware
 - On the right, the control software version

Fig. 40: Displaying the software version



- ↳ The machine performs a reference run:
The display shows the sewing program last used, or Manual mode.

5.8 Service mode

More information on the contents of Service mode can be found in the  *Service Instructions*.

5.9 Update machine software



Information

In machines with software version up to and including A.3.27 a bootloader update must be performed. In machines with software version from A.3.29 the software update can be performed immediately.



1. Download the bootloader software from the Dürkopp Adler website (<https://software.duerkopp-adler.com/maschinenprogramme.html>).
 2. Unpack the file on a USB key.
 2 folders are created: *bootscr* and *update*.
 3. Insert the USB key (2) in the USB port (3) at the control (1).
 4. Switch on the machine.
 The update starts. The LEDs (4) light up.
The update is finished when only the POWER LED glows.
-

Fig. 41: Update machine software



To perform the software update:

1. Download the machine-specific update from the Dürkopp Adler website (<https://software.duerkopp-adler.com/maschinenprogramme.html>).
- ↳ The program is packed in a .zip-file, the name consists of the part number of the program, the software version and the date, i. e. 9899_080600_000_A01.0.4_2013-12-10.zip
2. Unpack the .zip-file on a Dürkopp Adler USB key (part number 9835 301003).
- ↳ The update file has the ending *.dacing*.
3. Insert the USB key (2) in the USB port (3) at the control (1).
4. Switch on the machine.
- ↳ The update starts. The LEDs (4) light up.
 The update is finished when only the POWER LED glows.

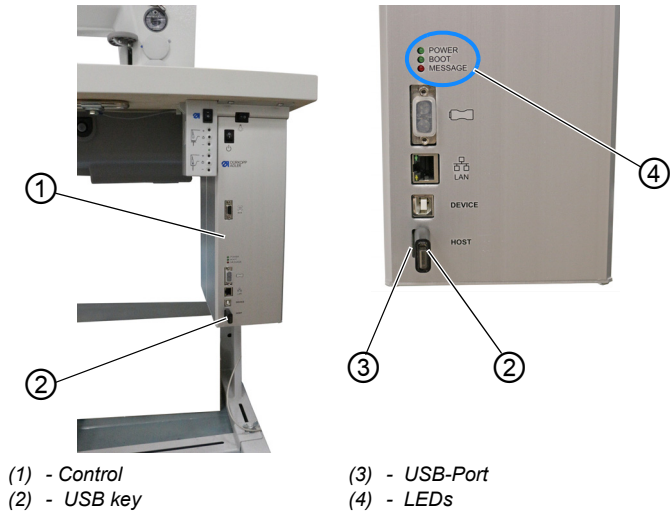

Important

5. Calibrate the electronic thread tension (📖 *Service Instructions*).
- ↳ The machine is ready to sew.

6 Programming (OP7000)

6.1 Control panel OP7000

All settings are performed using the **OP7000** control panel. If your machine is controlled by a different control panel, continue on  p. 37.

Fig. 42: Control panel OP7000



The activation of the sewing motor and the stepper motors is performed by the **DAC comfort**.

Up to 999 sewing programs can be saved.

Each sewing program can contain up to 30 sewing steps.

Each sewing step can be assigned various parameters such as stitch length, fullness values, curve support, thread tension, segment length etc.

The sewing programs are displayed continuously whilst sewing is in progress. Programs can be mirrored for the other side of the sewing material.

All functions and inputs are triggered by touching the screen.

Numeric values for the individual parameters and text for the program names can be input in the individual operating modes.

6.1.1 Entering numeric values









Fig. 43: Entering numeric values



The user interface for inputting numeric values consists of the following elements:

- Header, consisting of:
 - Symbol of the selected parameter
 - Name of the parameter
 - Value range of the parameter
 - Symbol for exiting the user interface
- Input line for the value
- Keypad

Meaning of the buttons

Symbol/Button	Meaning
 	Value input
	Change of plus/minus sign
	Input of a decimal point for values that permit places of decimals
 	Changing the value incrementally up or down
	Delete the input value
	Exit the user interface without inputting or saving any values
	Save the value that was input and exist the user interface

6.1.2 Entering text



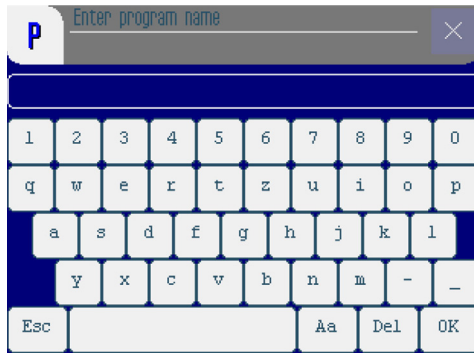





Fig. 44: Entering text



The user interface for inputting text consists of the following elements:

- Header, consisting of:
 - Symbol for new sewing program
 - Symbol for exiting the user interface
- Input line for the text
- Keypad

Meaning of the buttons

Symbol/Button	Meaning
	Input of numbers in the text
	Input of text
	Input of a hyphen
	Input of an underscore
	Exit the user interface without inputting or saving any text
	Input of a space
	Switching between upper case/lower case
	Delete letters or digits from the input line
	Save the value that was input and exist the user interface

6.2 control operating modes

The control offers 4 different operating modes:

- **MAN** (📖 p. 73)

Manual mode is the simplest operating mode.

In Manual mode, there are no sewing programs and no inputs for individual sewing steps.

Any changes made to parameters are applied immediately during the sewing process.

- **AUTO** (📖 p. 79)

Automatic mode allows sewing programs to be executed.

The seams are divided into individual steps within the sewing programs. Each step is assigned its own individual sewing parameters such as fullness etc.

- **EDIT** (📖 p. 88)

In Edit mode, new sewing programs can be created (PROGRAMMING), edited, deleted, copied and mirrored (EDIT) and also optimized (LENGTH CORRECTION).

- **SERVICE** (📖 p. 106)

Service mode contains functions for use during service work.

Service mode is passcode-protected to avoid accidentally changing the machine settings.

6.3 Manual mode MAN

Fig. 45: Manual mode MAN

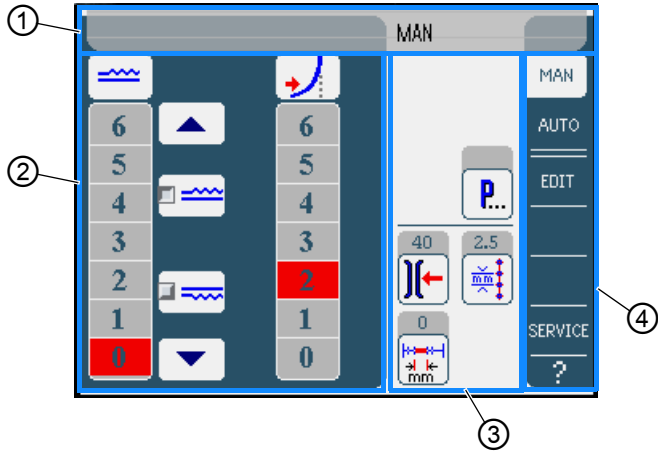

(1) - Header
 (2) - Left pane

(3) - Middle pane
 (4) - Right pane

Header (1)

The **MAN** operating mode is displayed.

Left pane (2)

Buttons for manually inputting the fullness are displayed here.

Middle pane (3)







The symbols for all the parameters that can be set in **MAN** operating mode are displayed here. The gray fields above the parameter symbols show the respective current values.

Right pane (4)

Another user interface or another operating mode can be selected here.

6.3.1 Parameters that can be set

The following table lists the parameters that can be set in **MAN** operating mode..

Symbol/Button	Meaning
	Setting the fullness,  p. 75
	Setting the curve support.
	Other program parameters in manual mode MAN ,  p. 76
	Setting the needle thread tension
	Setting the stitch length in mm



To set a parameter:

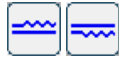

1. Tap the desired button.
- ↳ The user interface for setting the desired parameter is displayed.

For some parameters the setting is more than just a numerical value. These parameters are described below.



Setting the fullness

The following table lists the symbols and buttons for manually setting the fullness.

Symbol/Button	Meaning
	Inputting the fullness. The fullness setting is displayed by a button highlighted in red.
	Select the type of fullness: <ul style="list-style-type: none"> • Upper (upper transport) • Lower (lower transport) The fullness selected is displayed in an activated control field.
	Display of further buttons for inputting the fullness. The buttons 0 to 16 are available for input.



To set the fullness:

1. Select the type of fullness.
 - ↳ The type of fullness selected is displayed in an activated control field within the symbol.
2. If a higher or lower degree of fullness is required, use the arrow keys to display more buttons.
3. Input the fullness using the buttons **0** to **16**.



Setting the curve support

The following table lists the symbols and buttons for manually setting the curve support.
The default setting is a value of 2.

Symbol/Button	Meaning
	Inputting the curve support. The curve support is displayed by a button highlighted in red.



To set the curve support:

1. Input the curve support using the buttons **0** to **6**.



Other program parameters

A tap on the **Other program parameters** button will bring up an overview of all available parameters.

Fig. 46: Other program parameters

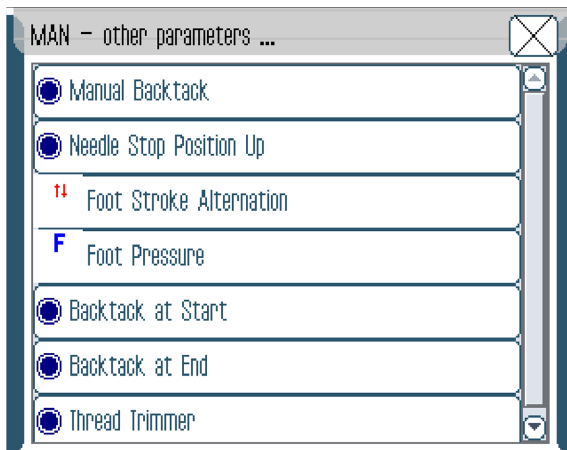

Parameters	Meaning
Manual Backtack	Manual bartack
Needle Stop Position Up	Needle position up when sewing stops Value range: 1 (= on) or 0 (= off)
Foot Stroke Alternation	Sewing foot alternation whilst the needle is in the sewing material Value range: 0 – 2.5 mm
Foot Pressure	Sewing foot pressure Value range: 1 – 10
Backtack at Start	Bartack at seam beginning Value range: 1 (= on) or 0 (= off)
Backtack at End	Bartack at seam end Value range: 1 (= on) or 0 (= off)
Thread Trimmer	Thread trimmer Value range: 1 (= on) or 0 (= off)

6.3.2 Sewing process

Sewing without fullness



To sew without fullness:

1. Set all fullness values to **0** ( p. 74).
2. Input the values for **needle thread tension** and **stitch length**.



3. Press the pedal forwards and sew.

↳ The length in mm sewn in the seam is displayed: 
When the thread is cut, the display is reset.

Sewing with fullness



To sew with fullness:

1. Change the desired fullness ( p. 74).
2. Push the pedal forwards and sew.

↳ The length in mm sewn in the seam is displayed: 
When the thread is cut, the display is reset.

Changing parameters in the middle of a seam



To change parameters in the middle of a seam:

1. Press Pedal to position **0**.
 2. Change the desired parameter on the control panel ( p. 74).
 3. Press the pedal forwards again and sew.
- ↳ The seam will be sewn using the altered parameter value.

6.4 Automatic mode AUTO

Fig. 47: Automatic mode AUTO

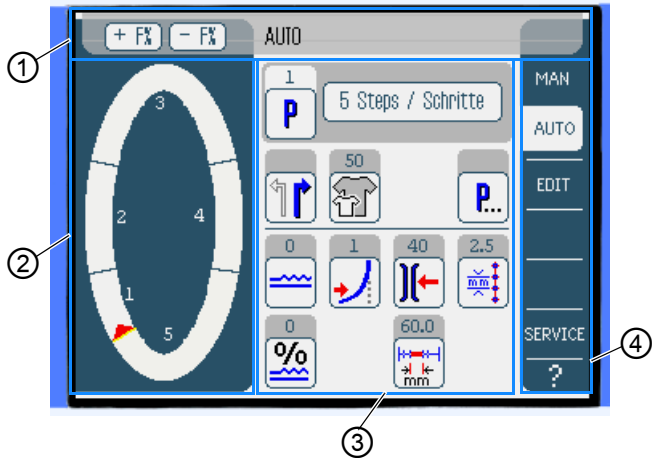

(1) - Header
 (2) - Left pane

(3) - Middle pane
 (4) - Right pane

Header (1)

The **AUTO** operating mode is displayed. The buttons **+ F%** and **- F%** offer quick access for setting the fullness values in %.

Left pane (2)

The graphical representation of the entire seam, divided into the number of programmed sewing steps, is displayed here. A red bar with an arrowhead indicates the direction of sewing and progress of the sewn seam.

Middle pane (3)













The number and the name of the selected sewing program are displayed here, together with the symbols for all the parameters that can be set. The gray fields above the parameter symbols show the respective current values.

Right pane (4)

Another user interface or another operating mode can be selected here.

6.4.1 Parameters that can be set

The following table lists the parameters that can be set in **AUTO** operating mode..

Symbol/Button	Meaning
	Program selection,  p. 81
	Select the right or left piece to be sewn
	Set the sewing material size,  p. 82
	Other program parameters in manula mode AUTO ,  p. 85
	Temporarily setting the fullness value until the next sewing step,  p. 83
	Applying a % correction to the fullness values of all sewing steps,  p. 84
	Setting the needle thread tension. If changed in AUTO operating mode, the value is permanently saved in the sewing program.
	Setting the stitch length in mm. If changed in AUTO operating mode, the value is permanently saved in the sewing program.



To set a parameter:

1. Tap the desired button.
 The user interface for setting the desired parameter is displayed.

For some parameters the setting is more than just a numerical value. These more complex parameters are described in detail below.

P **Selecting the sewing program**

Fig. 48: Selecting the sewing program

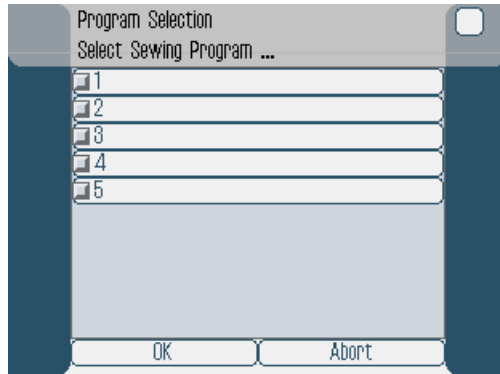

To select a sewing program:

1. Tap the desired sewing program.
 - ↳ The selected sewing program is displayed in an activated control field within the line.
2. Tap the **OK** button.
 - ↳ The selected sewing program is loaded in **AUTO** operating mode.

You can tap the **Abort** button to cancel the selection of the program.

- ↳ If necessary the selected sewing program is discarded, and the user interface for **AUTO** operating mode is displayed.



Setting the sewing material size

Fig. 49: Setting the sewing material size

Size [22 ... 142]			Germany Men		
52	62	72	102	122	142
56	60	70	80	118	138
48	58	68	94	114	134
46	56	66	90	110	130
44	54	64	86	106	>> 126
58	68	78	26	31	36
51	61	71	35	30	35
49	59	69	24	29	34
47	57	67	23	28	33
45	55	65	22	27	32

The following information is displayed:

- The currently selected size is indicated by a double arrow (>>).
- The sizes highlighted in red represent the reference sizes for the graduation logic.



To set the sewing material size:

1. Tap the desired sewing material size.
- ↳ The user interface for **AUTO** operating mode is displayed.





 **Temporarily correcting the fullness value until the next sewing step**

Fig. 50: Temporarily correcting the fullness value until the next sewing step

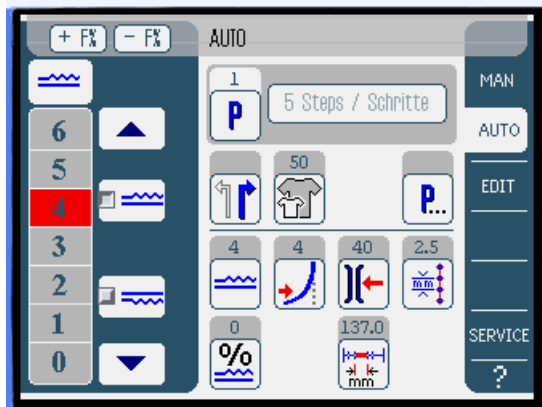

Buttons for manually inputting the fullness are displayed in the left pane.

Symbol/Button	Meaning
	Input the fullness. The fullness setting is displayed by a button highlighted in red.
	Select the type of fullness: • Upper (upper transport) • Lower (lower transport) The fullness selected is displayed in an activated control field within the symbol.
	Display of further buttons for inputting the fullness. The buttons 0 to 16 are available for input.



To set the fullness:

1. Select the type of fullness.
-  The type of fullness selected is displayed in an activated control field within the symbol.

2. If a higher or lower degree of fullness is required, use the arrow keys to display more buttons.
3. Input the fullness using the buttons **0** to **16**.



Information

The fullness value remains active until the next sewing step.



Correcting the fullness value

The fullness value can be corrected either by the buttons **+ F%** and **- F%** or the fullness correction parameter.

Fig. 51: Correcting the fullness value

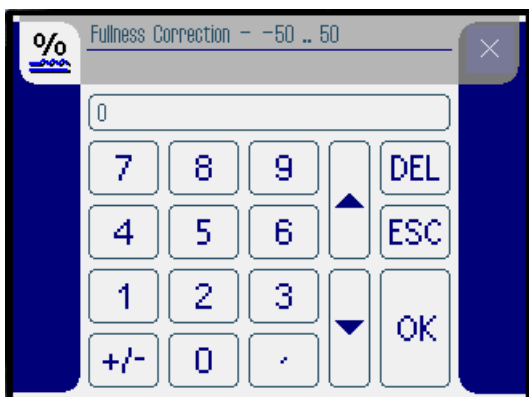

To correct the fullness value:

1. Input the correction value for the fullness in percent.
Information for inputting numeric values: p. 68.
2. Tap the **OK** button.
- ↳ The correction value is saved, and the previous user interface is displayed again.



Information

If changed in **AUTO** operating mode, the new correction value remains active until the control changes to the next program.



Other program parameters

A tap on the **Other program parameters** button will bring up an overview of all available parameters.

Fig. 52: Other program parameters

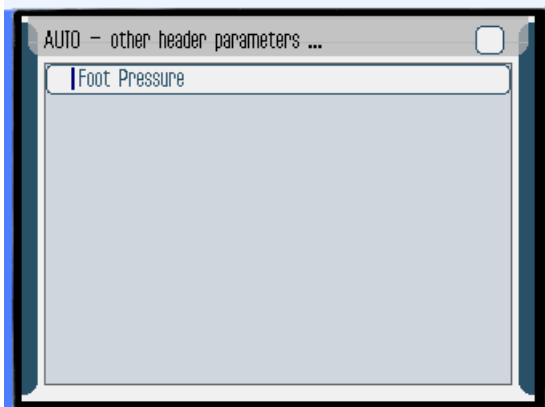

Parameters	Meaning
Foot Pressure	Sewing foot pressure Value range: 1 – 10

6.4.2 Sewing process



To sew:



1. Select a sewing program (📖 p. 81).
 ↳ The program number and name of the sewing program are displayed on the user interface. If no name has been saved for the selected sewing program, <No Name> is displayed.
2. Select the right or left piece to be sewn by tapping .
3. Select sewing material size (📖 p. 82).
4. Push the pedal forwards and sew the seam.
 ↳ The sewing progress is displayed graphically in the left pane as a red bar.



Fig. 53: Sewing process

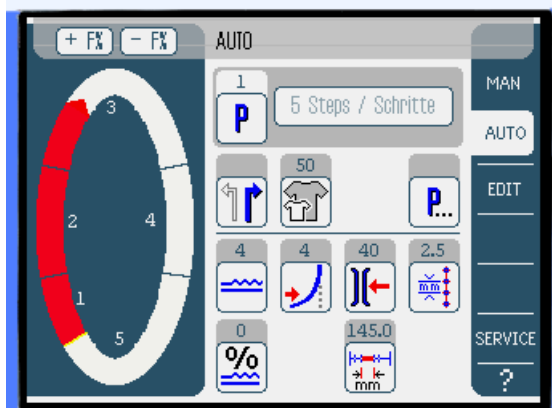

- ↳ The remaining sewing length per sewing step is displayed: .

Correcting the fullness before or during the seam



To correct the fullness before or during the seam:

1. Press Pedal to position **0**.



2. Change the fullness correction using the buttons **+F%** or **-F%**.



3. Push the pedal forwards and sew.

↳ The changed fullness value is applied and displayed.

Changing parameters during the seam



To change parameters during the seam:

1. Press pedal to position **0**.



2. Change the desired parameter on the control panel.



3. Push the pedal forwards and sew.

↳ The seam will be sewn using the altered parameter value.

Cancel sewing program



To cancel a sewing program:

1. Press the pedal fully back.

↳ The sewing program is canceled.

6.5 Programming mode EDIT

Fig. 54: Programming mode EDIT

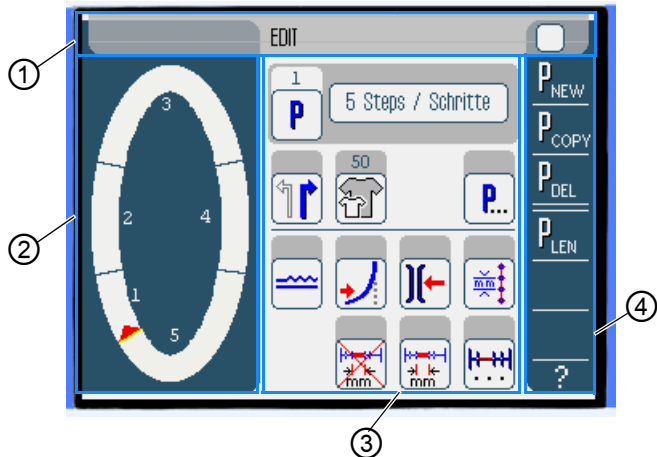

(1) - Header
(2) - Left pane

(3) - Middle pane
(4) - Right pane

Header (1)

The **EDIT** operating mode is displayed.

Left pane (2)

The graphical representation of the entire seam, divided into the number of programmed sewing steps, is displayed here.

Middle pane (3)















Existing sewing programs can be edited here (📖 p. 89). The number and the name of the selected sewing program are displayed, together with the symbols for all the parameters that can be set. The gray fields above the parameter symbols show the respective current values.

Right pane (4)

Here, sewing programs can be created (📖 p. 94), deleted (📖 p. 103), copied (📖 p. 103) and optimized (📖 p. 104).

6.5.1 Parameters that can be set

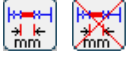
The following table lists the parameters that can be set in **EDIT** operating mode.

Symbol/Button	Meaning
	Changing the program name
	There is only one display in EDIT operating mode. A new sewing program is automatically assigned the next free program slot.
	Select the right or left piece to be sewn
	Set the sewing material size,  p. 90
	Other program parameters in operating mode EDIT ,  p. 92
	Set the fullness in the current sewing step,  p. 100
	Set the curve support in the current sewing step
	Set the needle thread tension in the current sewing step
	Set the stitch length in mm in the current sewing step
	Switch the seam length measurement in the current sewing step on or off
	Other sewing step parameters in operating mode EDIT ,  p. 93



To set a parameter:

1. Tap the desired button.
- ↳ The user interface for setting the desired parameter is displayed.

For some parameters the setting is more than just a numerical value. These more complex parameters are described in detail below.



Setting the sewing material size

Fig. 55: Setting the sewing material size

Size [22 ... 142]			Germany Men		
52	62	72	102	122	142
50	60	70	80	118	138
48	58	68	94	114	134
46	56	66	90	110	130
44	54	64	86	106	>> 126
58	68	78	26	31	36
51	61	71	25	30	35
49	59	69	24	29	34
47	57	67	23	28	33
45	55	65	22	27	32

The following information is displayed:

- The currently selected size is indicated by a double arrow (>>).
- The sizes highlighted in red represent the reference sizes for the graduation logic.



To set the sewing material size:

1. Tap the desired sewing material size.
- ↳ User interface **EDIT** is displayed.





 **Setting the fullness in the current sewing step**

Fig. 56: Setting the fullness in the current sewing step

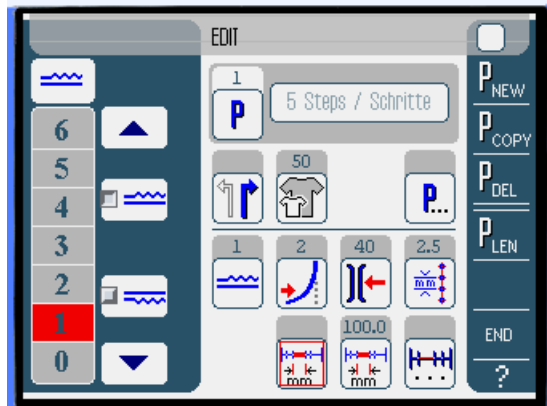

Buttons for manually inputting the fullness are displayed in the left pane.

Symbol/Button	Meaning
	Input the fullness. The fullness setting is displayed by a button highlighted in red.
	Select the type of fullness: • Upper (upper transport) • Lower (lower transport) The fullness selected is displayed in an activated control field.
	Display of further buttons for inputting the fullness. The buttons 0 to 16 are available for input.



To set the fullness:

1. Select the type of fullness.
 - ↳ The type of fullness selected is displayed in an activated control field within the symbol.

2. If a higher or lower degree of fullness is required, use the arrow keys to display more buttons.
3. Input the fullness using the buttons **0** to **16**.

P... **Other program parameters**

A tap on the **Other program parameters** button will bring up an overview of all parameters available in **EDIT** operating mode.

Fig. 57: Other program parameters

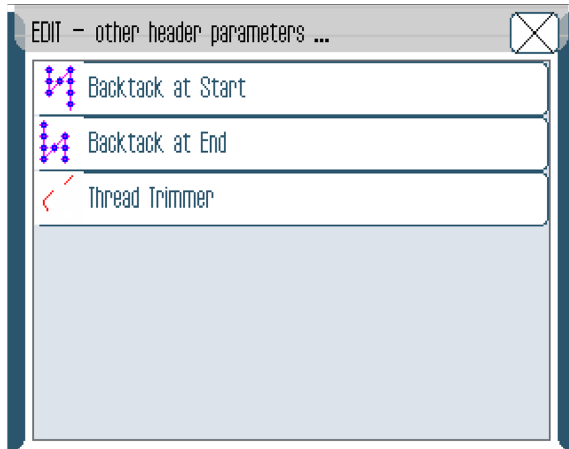

Parameters	Meaning
Backtack at Start	Bartack at seam beginning Value range: 1 (= on) or 0 (= off)
Backtack at End	Bartack at seam end Value range: 1 (= on) or 0 (= off)
Thread Trimmer	Thread trimmer Value range: 1 (= on) or 0 (= off)



Other sewing step parameters

A tap on the **Other sewing step parameters** button will bring up an overview of all available parameters.

Fig. 58: Other sewing step parameters

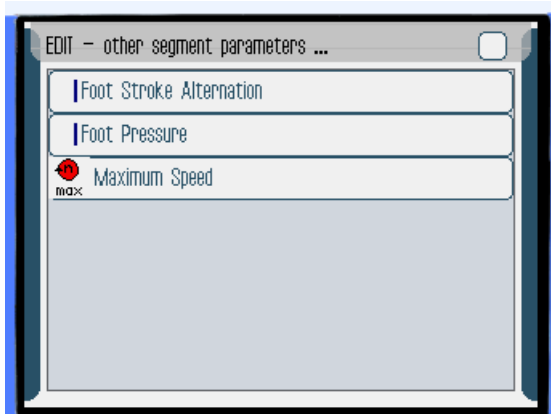

Parameters	Meaning
Foot Stroke Alternation	Sewing foot alternation whilst the needle is in the sewing material Value range: 0 – 2.5 mm
Foot Pressure	Sewing foot pressure Value range: 1 – 10
Maximum Speed	Max. sewing speed/speed Value range: 100 – 4000

6.5.2 Creating a new sewing program (PROGRAMMING)

Prerequisite:

- Operating mode **EDIT** is displayed.



To create a new sewing program:

1. Tap the **P_{NEW}** button.
- ↳ The **PROGRAMMING** user interface is displayed. Pressing the **P** button displays the number of the next free program slot.

Fig. 59: Creating a new seam program (1)

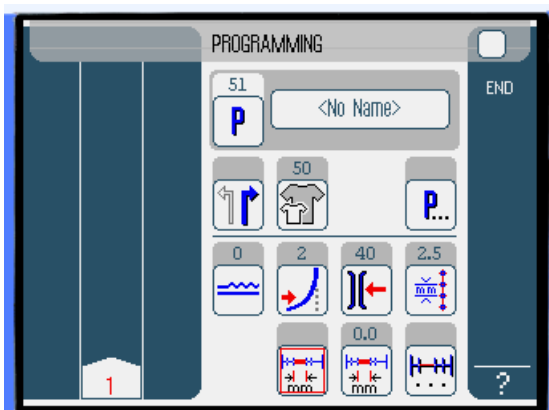

2. Tap **<No Name>** and input a name.
Information for inputting text: (📖 p. 70).



Information

If no name is input for the sewing program, **<No Name>** continues to be displayed.

- ↳ The first sewing step is displayed with its number in the left pane.
3. Input all the parameters for the first sewing step.

- 

4. Sew the first sewing step, or manually input the length of the sewing step using the **seam length measurement** parameter.
- 

5. Switch to the next sewing step by tapping on the number of the first sewing step or by using the knee lever.

 - 

The second sewing step is displayed with its number in the left pane.

Fig. 60: Creating a new seam program (2)

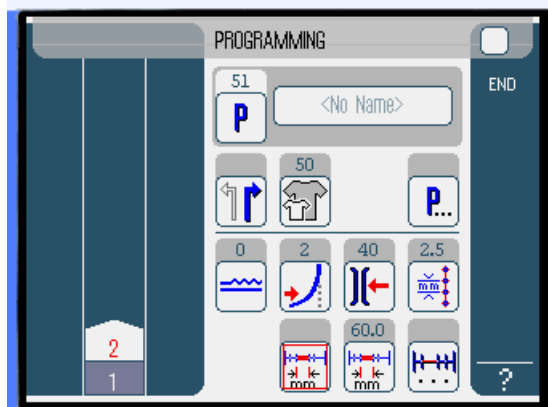

- 

6. Repeat sewing step 2 until all the sewing steps have been programmed.



7. Tap the **END** button or cut the threads.

↳ There are 3 variants for the sewing program response - depending on the user's input method:

Variant	Program display
The last programmed sewing step was sewn but not cut off, then ended with END .	continue with step 8
The last programmed sewing step was sewn and threads cut off.	continue with step 9
All sewing steps were input manually and ended with END .	continue with step 9

↳ If the threads were not cut after sewing, the message *Cut off thread* appears. The message is cleared, and the following selection window appears:

Fig. 61: Creating a new seam program (3)

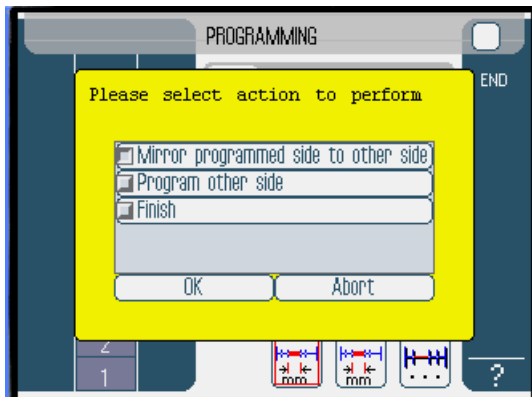

8. Select whether the new sewing program should be mirrored for the other side of the sewing material (*Mirror programmed side to other side*), the other side of the sewing material should be programmed (*Program other side*) or the programming should be ended (*Finish*).

↳ The selected function is indicated by an activated control field.











9. Tap the **OK** button.
 - ↳ The sewing program is saved. Depending on which function is selected, different buttons are displayed:





Function	Button
Mirror programmed side to other side	AUTO
Program other side	PROGRAMMING
Finish	AUTO

Tapping the **Abort** button closes the selection window and brings up the **AUTO** user interface. All previously entered data is deleted!

Parameters that can be set

The following table describes the parameters that can be set on the **PROGRAMMING** user interface.

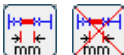
Symbol/Button	Meaning
	Input the program name
	There is only one display under PROGRAMMING . A new sewing program is automatically assigned the next free program slot.
	Select the right or left piece to be sewn
	Setting the sewing material size,  p. 99
	Other program parameters under PROGRAMMING ,  p. 101
	Setting the fullness in the current sewing step,  p. 100
	Setting the curve support in the current sewing step

Symbol/Button	Meaning
	Setting the needle thread tension in the current sewing step
	Setting the stitch length in mm in the current sewing step
	Switch the seam length measurement in the current sewing step on or off
	Other sewing step parameters under PROGRAMMING ,  p. 102



To set a parameter:

1. Tap the desired button.
 - ↳ The user interface for setting the desired parameter is displayed.

For some parameters the setting is more than just a numerical value. These more complex parameters are described in detail below.

Setting the sewing material size

Fig. 62: Setting the sewing material size

Size (22 ... 142)			Germany Men		
52	62	72	102	122	142
50	60	70	90	118	138
48	58	68	94	114	134
46	56	66	90	110	130
44	54	64	86	106	>> 126
58	68	78	26	31	36
53	61	71	55	30	35
49	59	69	24	29	34
47	57	67	23	28	33
45	55	65	22	27	32



- The currently selected size is indicated by a double arrow (>>).
- The sizes highlighted in red represent the reference sizes for the graduation logic.

 **Setting the fullness**

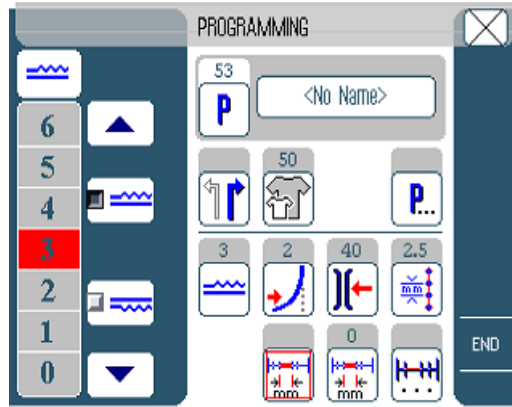
Fig. 63: Setting the fullness



Buttons for manually inputting the fullness are displayed in the left pane.

Symbol/Button	Meaning
	Input the fullness. The fullness setting is displayed by a button highlighted in red.
	Select the type of fullness: • Upper (upper transport) • Lower (lower transport) The fullness selected is displayed in an activated control field.
	Display of further buttons for inputting the fullness. The buttons 0 to 16 are available for input.



To set the fullness:

1. Select the type of fullness.
-  The type of fullness selected is displayed in an activated control field within the symbol.

2. If a higher or lower degree of fullness is required, use the arrow keys to display more buttons.
3. Input the fullness using the buttons **0** to **16**.

P... **Other program parameters**

A tap on the **Other program parameters** button will bring up an overview of all available parameters.

Fig. 64: Other program parameters

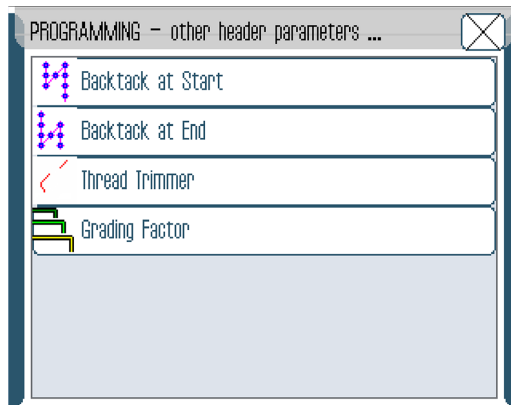

Parameters	Meaning
Backtack at Start	Bartack at seam beginning Value range: 1 (= on) or 0 (= off)
Backtack at End	Bartack at seam end Value range: 1 (= on) or 0 (= off)
Thread Trimmer	Thread trimmer Value range: 1 (= on) or 0 (= off)
Grading Factor	Grading factor Value range: 0.0 – 6.0 (% per size)



Other sewing step parameters

A tap on the **Other sewing step parameters** button will bring up an overview of all available parameters.

Fig. 65: Other sewing step parameters

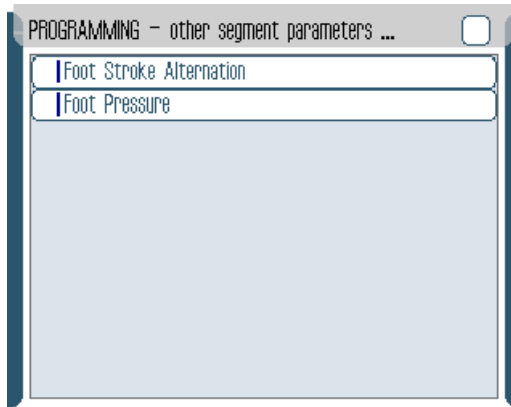

Parameters	Meaning
Foot Stroke Alternation	Sewing foot alternation whilst the needle is in the sewing material Value range: 0 – 2.5 mm
Foot Pressure	Sewing foot pressure Value range: 1 – 10



6.5.3 Copying the sewing program

Prerequisite:

- Operating mode **EDIT** is displayed.



To copy an existing sewing program:

1. Select a sewing program ( p. 81).
2. Tap the  button.
 - ↳ The sewing program is copied and saved in the next free program slot. An appropriate message is displayed.



6.5.4 Deleting the sewing program

Prerequisite:

- Operating mode **EDIT** is displayed.



To delete an existing sewing program:

1. Select a sewing program ( p. 81).
2. Tap the  button.
 - ↳ A message is displayed asking whether you really wish to delete the active sewing program.
3. To delete the program, confirm by tapping the **Yes** button.
 - ↳ The sewing program is deleted. An appropriate message is displayed.

6.5.5 Length correction (LENGTH CORRECTION)

All the sewing steps are graded with the same factor.
In some sewing steps it is important for the quality of the result that the grading is greater or less than this.
You can use the length correction to achieve these local adjustments.

Prerequisite:

- Operating mode **EDIT** is displayed.



To use the length correction:

1. Tap the **P_{LEN}** button.
- ↳ The **LENGTH CORRECTION** user interface is displayed.

Fig. 66: Length correction (LENGTH CORRECTION) (1)

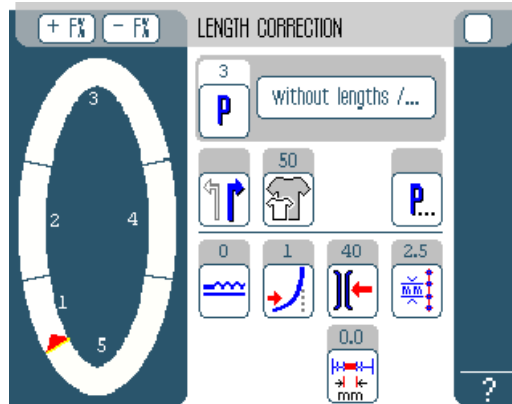

2. Sew the sewing step.



3. Switch to the next sewing step by tapping on the number of the first sewing step or by using the knee lever.

↳ The sewing progress is displayed graphically.

Fig. 67: Length correction (LENGTH CORRECTION) (2)

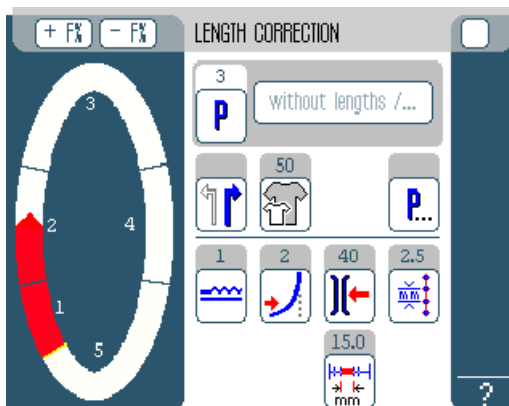

4. Do the same with all further sewing steps.



5. After the last sewing step tap the **END** button.

↳ This closes the length correction, and the operating mode **EDIT** (📖 p. 88) opens.

6.6 Displaying the software version



To display the software version:

1. Switch on and off the machine.
- ↳ The following appears on the display:
 - On the left, the class
 - On the right, the firmware
 - ↳ The machine performs a reference run.
The control starts in the operating mode that was active when it was switched off - **MAN** or **AUTO**.

6.7 Operating mode SERVICE

More information on the contents of Service mode can be found in the  *Service Instructions*.

6.8 Update machine software



Information

In machines with software version up to and including A.3.27 a bootloader update must be performed. In machines with software version from A.3.29 the software update can be performed immediately.

1. Download the bootloader software from the Dürkopp Adler website (<https://software.duerkopp-adler.com/maschinen-programme.html>).
2. Unpack the file on a USB key.
 - ↳ 2 folders are created: *bootscr* and *update*.
3. Insert the USB key (2) in the USB port (3) at the control (1).
4. Switch on the machine.
 - ↳ The update starts. The LEDs (4) light up.
The update is finished when only the POWER LED glows.

Fig. 68: Update machine software (1)

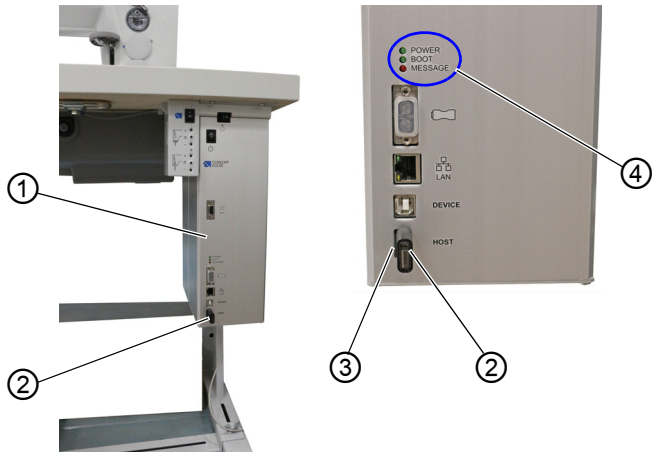

(1) - Control
(2) - USB key

(3) - USB-Port
(4) - LEDs



To perform the software update:

1. Download the update file from the Dürkopp Adler website.
The file is named
9899_65500_700_A03.61_2016-08-15.jcbl
2. Copy the update file on a Dürkopp Adler USB key (part number 9835 301003).

Fig. 69: Update machine software (2)

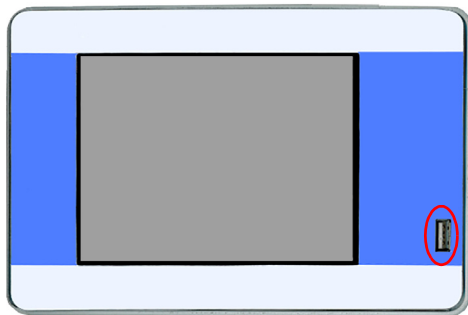

3. Switch off the machine and wait and wait for approx. 15 seconds.
4. Connect the Dürkopp Adler USB key to the OP7000.

5. Restart the machine.
- ↳ The OP7000 detects the USB key and updates the software.

Fig. 70: Update machine software (3)

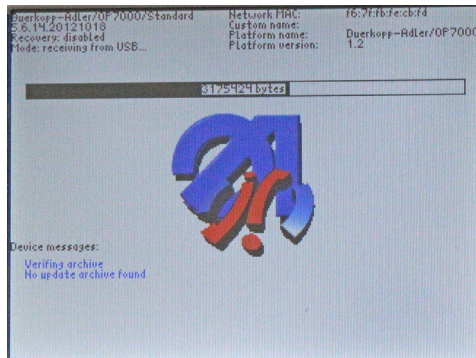

- ↳ The update will take approx. 2 minutes.



Important

Do not switch off the machine during the update!

- ↳ Remove the USB key when prompted to do so.

Fig. 71: Update machine software (4)

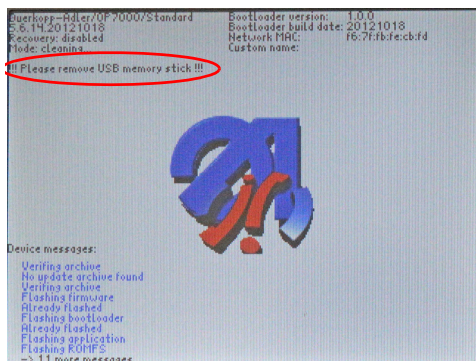

- ↪ The machine restarts automatically.
The machine shows notice 8403: *Machine has an out-dated program. Should a new program be transmitted?*

Fig. 72: Update machine software (5)

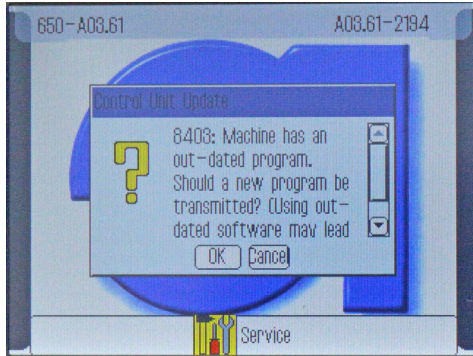

6. Confirm with **OK**.
- ↪ The update is carried out.

Fig. 73: Update machine software (6)

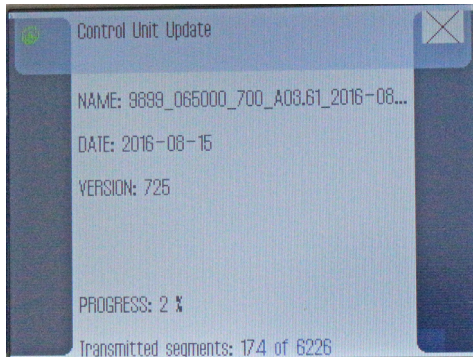

Important

- Do not switch off the machine during the update!
- ↪ The display shows notice 8408: *Waiting for reset by machine ...*

Fig. 74: Update machine software (7)

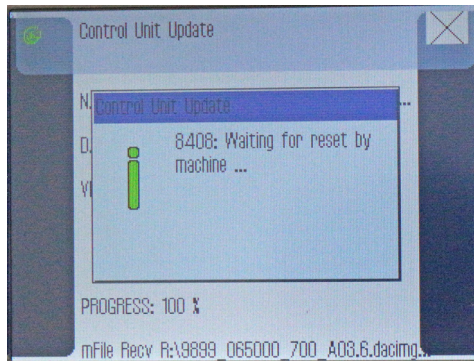

- ↪ The machine restarts automatically.
After restarting, the machine loads the start screen.



Information

If the machine does not restart automatically, you have to restart it via the service menu (📖 *Service Instructions*).



Important

7. Calibrate the electronic thread tension.
(📖 *Service Instructions*).

OR



8. Press **CANCEL** to cancel the update.

↪ The following warning appears:

Fig. 75: Update machine software (8)

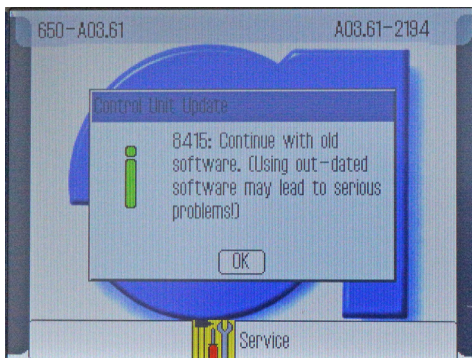

- After confirming with **OK**, you can continue working with the old machine software.

**Important**

Working with outdated software can lead to serious problems because the control software and the operating software do not fit together.

7 Maintenance

WARNING



Risk of injury from sharp parts!

Punctures and cutting possible.

Prior to any maintenance work, switch off the machine or set the machine to threading mode.

WARNING



Risk of injury from moving parts!

Crushing possible.

Prior to any maintenance work, switch off the machine or set the machine to threading mode.

This chapter describes maintenance work that needs to be carried out on a regular basis to extend the service life of the machine and achieve the desired seam quality.

Advanced maintenance work may only be carried out by qualified specialists ( *Service Instructions*).

Maintenance intervals

Work to be carried out	Operating hours			
	8	40	160	500
Machine head				
Removing lint and thread remnants	●			
Clean engine fan filter	●			
Check the upper and lower conveyor belts for wear		●		
Check sewing foot for wear		●		
Lubricate the joints on the gear				●
Lubricating the needle bar				●

7.1 Cleaning

WARNING



Risk of injury from flying particles!

Flying particles can enter the eyes, causing injury.

Wear safety goggles.

Hold the compressed air gun so that the particles do not fly close to people.

Make sure no particles fly into the oil pan.

NOTICE

Property damage from soiling!

Lint and thread remnants can impair the operation of the machine.

Clean the machine as described.

NOTICE

Property damage from solvent-based cleaners!

Solvent-based cleaners will damage paintwork.

Use only solvent-free substances for cleaning.

The following areas must be cleaned with a compressed air pistol or a brush:

- Throat plate
- Hook
- Bobbin case and interior
- Thread trimmer
- Needle
- Engine fan filter
- Conveyor belts
- Sewing feet
- Belt tensioner



To clean the machine:

1. Remove any lint and thread remnants using a compressed air pistol or a brush.

7.2 Lubricating

CAUTION



Risk of injury from contact with oil!

Oil can cause a rash if it comes into contact with skin.

Avoid skin contact with oil.

If oil has come into contact with your skin, wash the affected areas thoroughly.

NOTICE

Property damage from incorrect oil!

Incorrect oil types can result in damage to the machine.

Only use oil that complies with the data in the instructions.

CAUTION



Risk of environmental damage from oil!

Oil is a pollutant and must not enter the sewage system or the soil.

Carefully collect up used oil.

Dispose of used oil and oily machine parts in accordance with national regulations.

Lubricate the machine as follows:



1. Lubricate the following areas on the machine head with lubricating grease:
 - Joints on the gear
 - Needle bar

Fig. 76: Lubricating

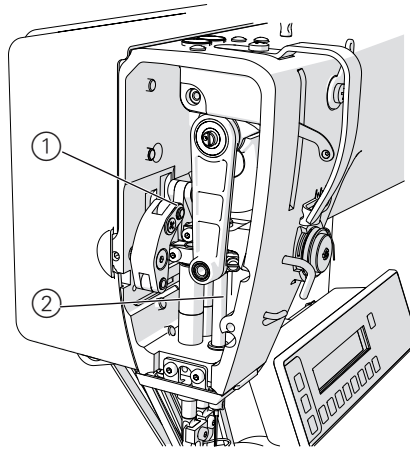

(1) - Joints on the gear

(2) - Needle bar

7.3 Parts list

A parts list can be ordered from Dürkopp Adler. Or visit our website for further information at:

www.duerkopp-adler.com



8 Setup

WARNING



Risk of injury from cutting parts!

Cutting is possible.

Only qualified personnel is allowed to set up the machine.

Wear safety gloves

WARNING



Risk of injury from moving parts!

Crushing is possible.

Only qualified personnel is allowed to set up the machine.

Wear safety gloves .

8.1 Check the scope of delivery

The scope of delivery depends on your specific order.

Check that all parts required are present before installing the machine.

8.2 Removing the transport locks

When you have installed the machine which you bought, you must remove the following transport locks:

- Lashing straps and wooden blocks from the machine head, the tabletop and the stand
- Restrain block and lashing straps from the sewing drive

8.3 Assembling the stand

Fig. 77: Assembling the stand

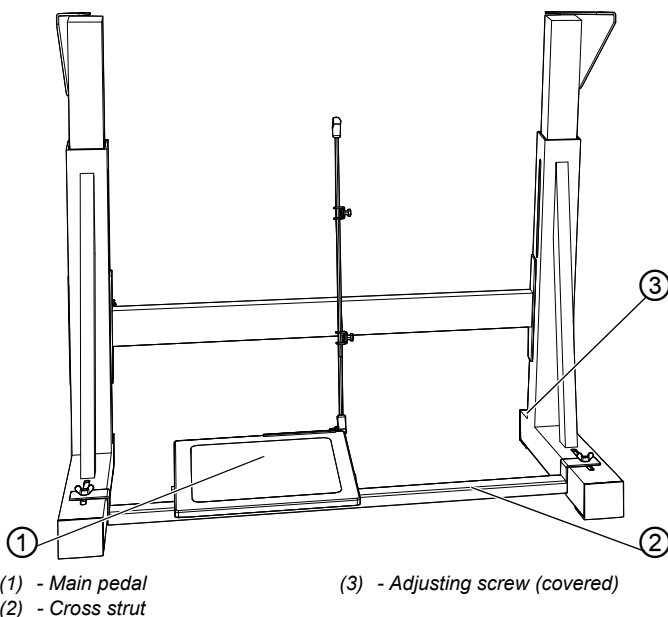

To assemble the stand:

1. Attach the main pedal (1) to the cross strut (2).
2. Attach the additional pedal (optional) to the cross strut (2).
3. Attach the cross strut (2) to the stand.
4. After the machine has been fully assembled, align the pedals (📖 p. 123).
5. Turn the adjusting screw (3) to ensure that the stand is positioned securely. All 4 feet of the stand must be in contact with the floor.

8.4 Pre-assembling the tabletop

Fig. 78: Pre-assembling the tabletop

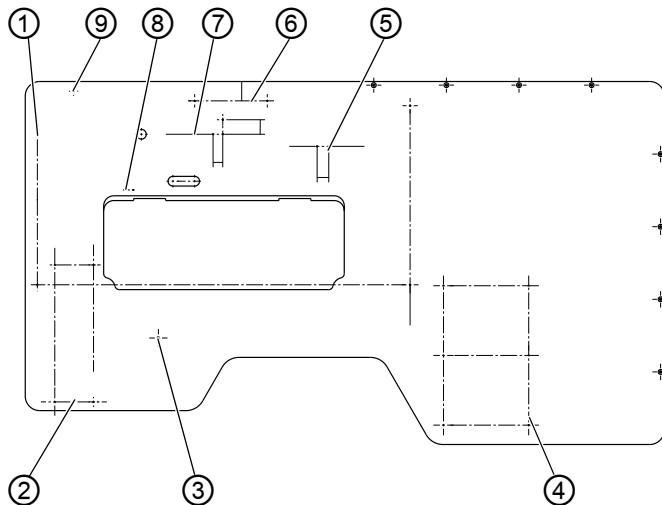

- | | |
|--|--|
| (1) - Stand | (6) - Cable duct |
| (2) - Control | (7) - Sollwertgeber Setpoint device for main pedal |
| (3) - Knee lever | (8) - Tilt sensor |
| (4) - Strain relief mechanism | (9) - Drawer |
| (5) - Setpoint device for additional pedal | |



To pre-assemble the tabletop:

1. Turn the tabletop over so that its bottom side is facing up.
2. Tighten the control at (2) (chipboard screws 5 x 30).
3. Use screws to tighten the permanent magnets of the tilt sensor (8) for the machine head (accessory pack) on the underside of the tabletop.
4. Tighten the drawer and its brackets at (9) (chipboard screws 3.5 x 17).
5. Tighten the knee lever at (3).
6. Tighten the strain relief mechanism at (4) (chipboard screws 3.5 x 17).
7. Tighten the cable duct (40 x 40 x 250 mm long) at (6) (chipboard screws 3.5 x 17).

8. Tighten the setpoint device for the main pedal at (7)
(chipboard screws 4 x 20).
9. Tighten the setpoint device for the additional pedal at (5)
(chipboard screws 4 x 20).

Larger scale diagrams can be found in the **Appendix** (📖 p. 163).

8.5 Completing the tabletop

Fig. 79: Completing the tabletop

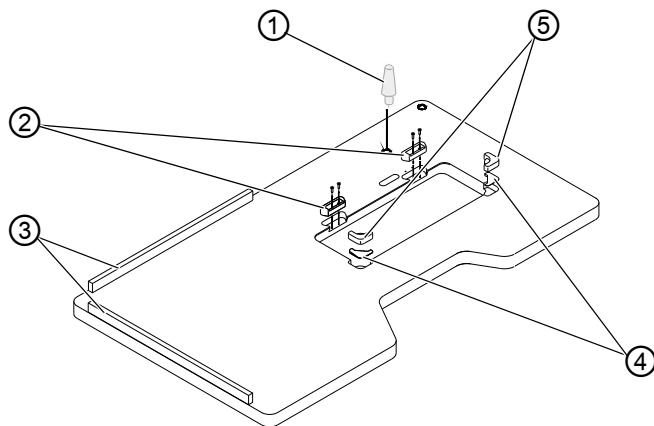

- | | |
|----------------------------|------------------------|
| (1) - Machine head support | (4) - Oblique fittings |
| (2) - Hinge mountings | (5) - Rubber corners |
| (3) - Edge strips | |



To complete the tabletop:

1. Insert the oblique fittings (4).
2. Insert the rubber corners (5) into the tabletop.
3. Using 4.5 x 15 (4x) screws, tighten the hinge mountings (2).
4. Using 4.5 x 55 (8x) screws, screw the edge strips (3) to the tabletop.
5. Insert the machine head support (1).

8.6 Attaching the tabletop and pedals to the stand

Fig. 80: Attaching the tabletop and pedals to the stand

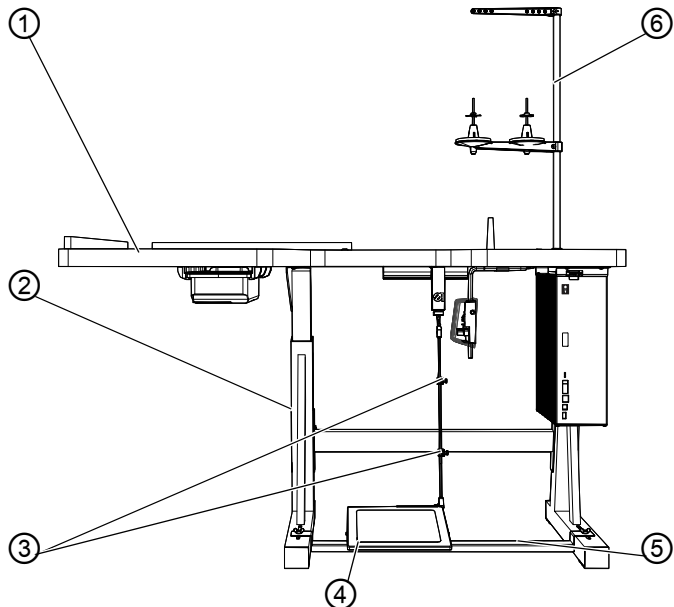

- | | |
|----------------|--------------------------|
| (1) - tabletop | (4) - Main pedal |
| (2) - Stand | (5) - Stand strut |
| (3) - Screws | (6) - Thread reel holder |



To attach the tabletop and the pedals to the stand:

1. Using wood screws (6 x 30), attach the stand (2) to the tabletop (1). Drill pilot holes for the wood screws.
2. Observe the center marks for the stand.
3. Turn the stand (2) the right way up.
4. Align the pedals.
5. For ergonomic reasons, align the pedals laterally so that the center of the main pedal (4) is directly beneath the needle.
The stand strut (5) is provided with slotted holes to allow alignment of the pedal.
6. Loosen the screws (3).

7. Adjust the height of the Pedal rods so that in the home position the pedal slope is about 10°.
8. Tighten the screws (3).
9. Insert the thread reel holder (6) into the hole in the tabletop (1) and secure it with a nut and washer.
10. Align thread reel holder and thread guide.



Important

The thread guide must be positioned vertically above the thread reel holder.

8.7 Setting the working height

WARNING



Risk of injury from moving parts!

When loosening the screws at the frame braces the tabletop can sink down by its weight. Crushing is possible.

Take care not to crush your hands when loosening the screws.

CAUTION



Risk of impairment of the musculoskeletal system from wrong adjustment!

The musculoskeletal system of the operator can be damaged by noncompliance of the ergonomic requirements.

Adjust the working height to the body dimension of the person who will operate the machine.

The working height can be adjusted between 780 and 900 mm (measured to the upper edge of the table plate).

Fig. 81: Setting the working height

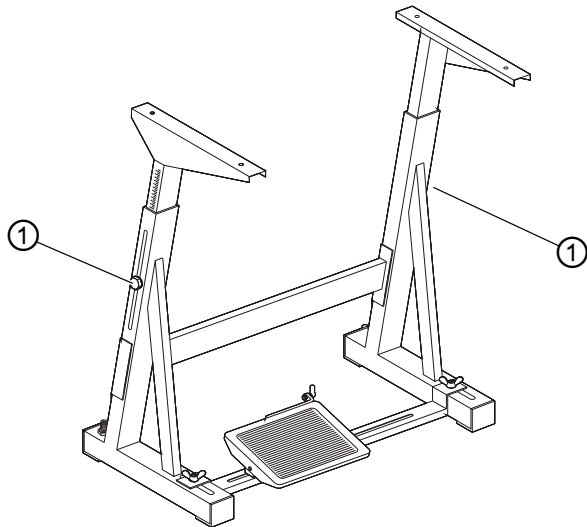

(1) - Screws



To set the working height:

1. Slacken the screws (1) on the frame bars.
2. Set the tabletop to the desired working height.
3. To avoid jamming, slide the tabletop in or out evenly at both sides.
4. Tighten the screws (1).

8.8 Inserting the machine head

WARNING



Risk of injury from tipping machine upper part!

Crushing is possible.

Secure the machine upper part against tipping when you transport the machine.

Fig. 82: Inserting the machine head

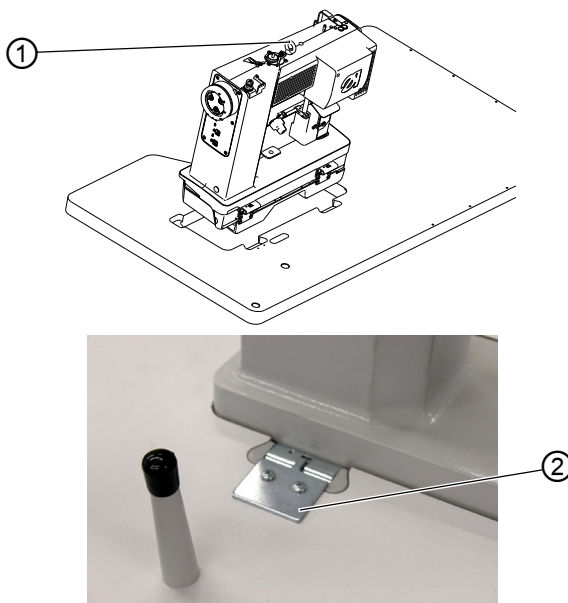

(1) - Ring bolt

(2) - Clamping plate



To insert the machine head:

1. Using the ring bolt (1), lift the machine upper part and insert it into the cut-out on the tabletop.
2. After the upper part has been placed in position, immediately connect the bracket (2) which prevents the upper part coming loose if the tabletop is tipped.

The bracket is included in the accessories pack for the upper part.

If the machine is supplied ready assembled, the ring bolt is included in the accessories pack.

8.9 Electrical connection

DANGER



Risk of death from live components!

Severe injury to life and limb from electric shock can occur.

The machine may ONLY be connected by qualified specialists.

Disconnect the power plug before carrying out work on the electrical equipment.

Make sure the machine cannot be accidentally switched back on.

8.9.1 Connecting the cables to the machine head

Fig. 83: Connecting the cables to the machine head (1)

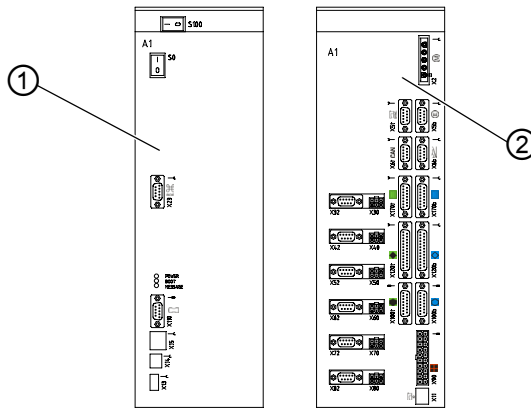

(1) - Front side

(2) - Rear side

All cables are color coded.



To connect the machine head cables:

1. Lay the cables to the control and fix them in place with cable ties.
2. Insert the plug following the marking on the rear (2) of the control.

8.9.2 Connecting the LED sewing lamp

Fig. 84: Connecting the LED sewing lamp

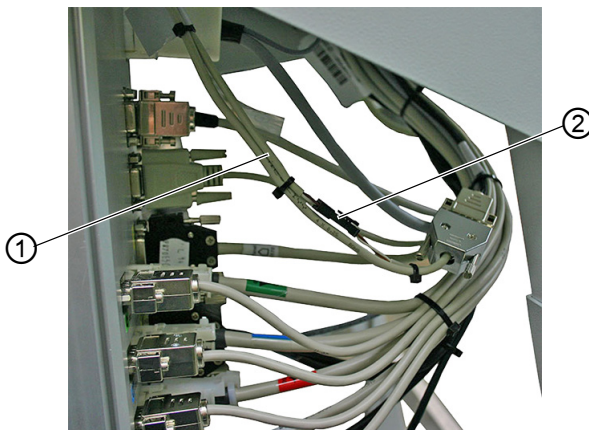

(1) - Cable

(2) - 2-pin plug



To connect the LED sewing lamp:

1. Connect the cable (1) of the LED sewing lamp with the 2-pin plug (2).
2. Connect the machine ID following the labeling on the rear of the control

8.9.3 Connecting the setpoint device to the control

Fig. 85: Connecting the setpoint device to the control

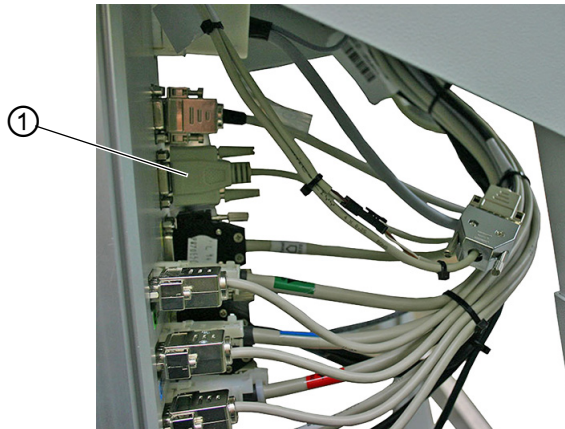

(1) - Setpoint device for main pedal



To connect the setpoint device to the control:

1. Connect the setpoint device for the main pedal to connector X5b .
2. If present, connect the setpoint device of the additional pedal to connector X440; the cable hangs freely in the cable harness.

8.9.4 Establishing equipotential bonding



Important

Before putting the machine into operation, you must establish equipotential bonding in all necessary places.



Establish equipotential bonding as follows:

1. Establish equipotential bonding as specified in the wiring diagram ( p. 163).

8.9.5 Connecting the knee lever

Fig. 86: Connecting the knee lever

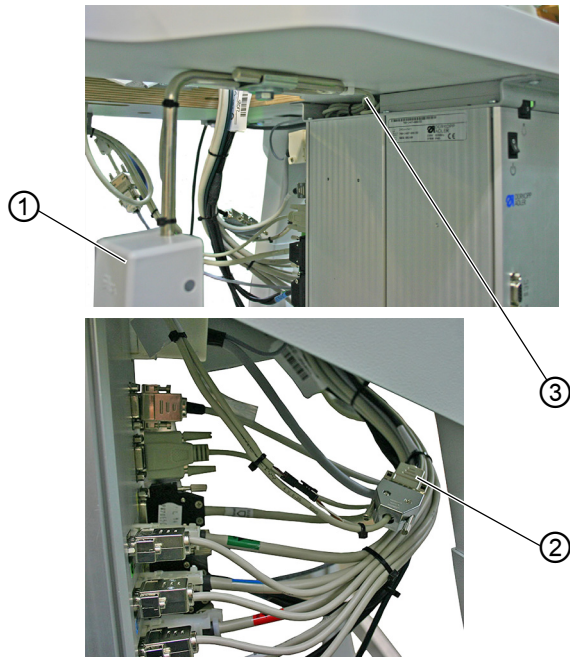

(1) - Knee lever

(2) - Plug

(3) - Cable



To connect the knee lever:

1. Lay the cable (3) from the knee lever (1) to the control and connect it to the plug (2).

8.9.6 Connecting the control panel

Connecting the control panel OP3000

Fig. 87: Connecting the control panel OP3000

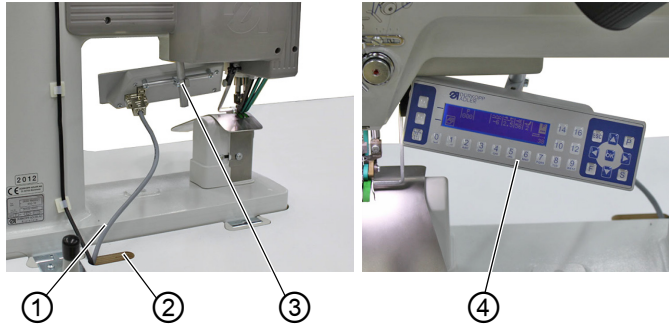

(1) - Cable
(2) - tabletop opening

(3) - Retainer
(4) - Control panel



To connect the control panel **OP3000**:

1. Screw the control panel (4) on the bracket (3) and align it.
2. Plug the plug for the cable (1) on to the control panel, through the tabletop opening (2) to the control cabinet, and connect it to the socket (X170 Panel).

Connecting the control panel OP7000

Fig. 88: Connecting the control panel OP7000

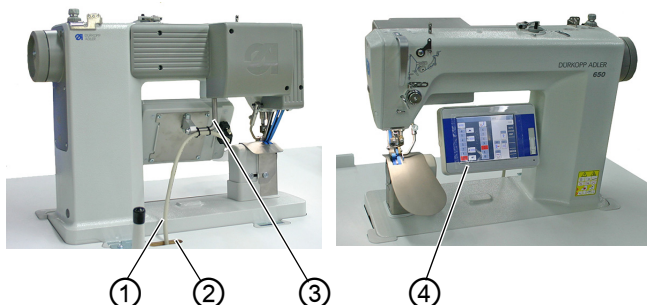

- | | |
|------------------------|---------------------|
| (1) - Cable | (3) - Retainer |
| (2) - tabletop opening | (4) - Control panel |



To connect the control panel **OP7000**:

1. Tighten the control panel (8) to the bracket (7) and align it.
2. Insert the plug for the cable (6) at the control panel, guide it through the tabletop opening (5) to the control, and connect it to the socket (X170b).

8.10 Carrying out a test run

CAUTION



Risk of injury from sharp parts!





Punctures possible.

Switch off the machine before threading the needle or hook thread.

Perform a test run when setup is complete.



To perform a test run:

1. Insert the power plug.
2. Wind on the hook thread ( p. 32).
3. Switch on the machine.
4. Fill the bobbin at medium speed.
5. Switch off the machine.
6. Thread the needle and hook threads ( p. 22) and ( p. 25).
7. Switch on the machine.
8. Position the sewing material.
9. Perform a test run, first at low speed and then at continually increasing speeds.
10. Check that the seams conform to the desired requirements.
11. If the requirements are not satisfied:
Alter the thread tension ( p. 27) and ( p. 32).

If necessary, also check the settings listed in the  *Service Instructions* and correct them as required.

9 Decommissioning

WARNING



Risk of injury from a lack of care!

Serious injuries may occur.

ONLY clean the machine when it is switched off.
Allow ONLY trained personnel to disconnect the machine.

CAUTION



Risk of injury from contact with oil!

Oil can cause a rash if it comes into contact with skin.

Avoid skin contact with oil.

If oil has come into contact with your skin, wash the affected areas thoroughly.



To decommission the machine:

1. Switch off the machine.
2. Unplug the power plug.
3. If applicable, disconnect the machine from the compressed air supply.
4. Remove residual oil from the oil pan using a cloth.
5. Cover the control panel to protect it from soiling.
6. Cover the control to protect it from soiling.
7. Cover the entire machine if possible to protect it from contamination and damage.

10 Disposal

CAUTION



Risk of environmental damage from improper disposal!

Improper disposal of the machine can result in serious environmental damage.

ALWAYS comply with the national regulations regarding disposal.

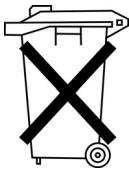

The machine must not be disposed of in the normal household waste.

The machine must be disposed of in a suitable manner in accordance with all applicable national regulations.

When disposing of the machine, be aware that it consists of a range of different materials (steel, plastic, electronic components, etc.). Follow the national regulations when disposing these materials.

11 Troubleshooting

11.1 Customer Service

Contact for repairs and issues with the machine:

Dürkopp Adler GmbH

Potsdamer Str. 190
33719 Bielefeld, Germany

Tel. +49 (0) 180 5 383 756

Fax +49 (0) 521 925 2594

Email: service@duerkopp-adler.com

Internet: www.duerkopp-adler.com



11.2 Messages of the software

Please contact customer service if an error occurs that is not described here. Do not attempt to correct the error yourself!

Table of software messages

Code	Type	Possible causes	Remedial action
1000	Error	Sewing motor error: <ul style="list-style-type: none"> Encoder plug (Sub-D, 9-pin) not connected or defective Encoder defective 	<ul style="list-style-type: none"> Check the connection of the encoder cable and replace, if necessary
1001	Error	Sewing motor error: <ul style="list-style-type: none"> Sewing motor plug not connected or defective 	<ul style="list-style-type: none"> Check the connection of the sewing motor cable Test sewing motor phases (R = 2.8Ω, high impedance to PE) Replace the encoder Replace the sewing motor Replace the control
1002	Error	Sewing motor insulation error	<ul style="list-style-type: none"> Check motor phase and PE for low-impedance connection Replace the encoder Replace the sewing motor
1004	Error	Sewing motor error: <ul style="list-style-type: none"> Incorrect direction of rotation 	<ul style="list-style-type: none"> Replace the encoder Check plug assignment and change, if necessary Check wiring in machine distributor and change it, if necessary Test motor phases and check for correct value
1005	Error	Sewing motor current error: <ul style="list-style-type: none"> Sewing motor blocked Encoder cable not connected or defective Encoder defective 	<ul style="list-style-type: none"> Remove the blockage Check the encoder cable and replace, if necessary Replace the sewing motor

Code	Type	Possible causes	Remedial action
1006	Error	Sewing motor error: <ul style="list-style-type: none"> • Max. speed exceeded • Sewing motor cable defective • Sewing motor defective 	<ul style="list-style-type: none"> • Switch the machine off and on again • Replace the encoder • Perform reset • Replace the sewing motor • Contact customer service
1007	Error	Error in the reference run	<ul style="list-style-type: none"> • Replace the encoder • Eliminate stiff movement in the machine
1008	Error	Sewing motor encoder error	<ul style="list-style-type: none"> • Replace the encoder
1010	Error	Sewing motor synchronization error: <ul style="list-style-type: none"> • External synchronizer plug (Sub-D, 9-pin) not connected 	<ul style="list-style-type: none"> • Connect plug of external synchronizer to control, use correct connection (Sync) • Replace the reference switch or synchronizer • Only required for machines with transmission!
1011	Error	Sewing motor synchronization error (Z pulse)	<ul style="list-style-type: none"> • Switch off the control, use handwheel to turn and switch on the control again • If error is not corrected, check encoder
1012	Error	Sewing motor synchronization error	<ul style="list-style-type: none"> • Replace the synchronizer
1051	Error	Sewing motor timeout: <ul style="list-style-type: none"> • Cable to sewing motor • Reference switch defective • Reference switch defective 	<ul style="list-style-type: none"> • Replace the cable • Replace the reference switch
1052	Error	Sewing motor overcurrent: <ul style="list-style-type: none"> • Sewing motor cable defective • Sewing motor defective • control defective 	<ul style="list-style-type: none"> • Replace the sewing motor cable • Replace the sewing motor • Replace the control
1053	Error	Sewing motor overvoltage	<ul style="list-style-type: none"> • Check the mains voltage
1054	Error	Internal short circuit	<ul style="list-style-type: none"> • Replace the control

Code	Type	Possible causes	Remedial action
1055	Error	Sewing motor overload (I ² T): <ul style="list-style-type: none"> • Sewing motor not moving freely or blocked • Sewing motor defective • control defective 	<ul style="list-style-type: none"> • Remove the cause of the stiff movement or blockage • Replace the sewing motor • Replace the control
1056	Error	Sewing motor overtemperature: <ul style="list-style-type: none"> • Sewing motor not moving freely • Sewing motor defective • control defective 	<ul style="list-style-type: none"> • Correct the cause of not moving freely • Replace the sewing motor • Replace the control
1058	Error	Sewing motor speed greater than setpoint: <ul style="list-style-type: none"> • Reference switch defective • Sewing motor defective 	<ul style="list-style-type: none"> • Replace the reference switch • Replace the sewing motor
1060	Error	PowerParts	<ul style="list-style-type: none"> • Replace the control
1061	Error	Sewing motor disturbance: <ul style="list-style-type: none"> • Encoder defective • Sewing motor defective 	<ul style="list-style-type: none"> • Switch the machine off and on again • Replace the encoder • Replace the sewing motor • Contact customer service
1062	Error	Sewing motor disturbance (IDMA auto increment)	<ul style="list-style-type: none"> • Switch the machine off and on again
1120	Error	Software error: <ul style="list-style-type: none"> • Parameter not initialized 	<ul style="list-style-type: none"> • Perform a software update
1203	Information	Sewing motor: Position not reached	<ul style="list-style-type: none"> • Switch the machine off and on again • Perform a software update • Contact customer service
1302	Error	Sewing motor current error: <ul style="list-style-type: none"> • Sewing motor blocked • Encoder cable not connected or defective • Encoder defective 	<ul style="list-style-type: none"> • Remove the blockage • Check the encoder cable and replace, if necessary • Replace the sewing motor
1330	Error	Sewing motor not responding	<ul style="list-style-type: none"> • Switch the machine off and on again • Perform a software update • Contact customer service

Code	Type	Possible causes	Remedial action
2102	Error	X-axis stepper motor: <ul style="list-style-type: none"> • Stepper motor not moving freely or blocked • Encoder cable not connected or defective • Stepper motor cable not connected or defective • Encoder defective • Stepper motor defective 	<ul style="list-style-type: none"> • Remove the cause of the stiff movement or blockage • Check the encoder cable and replace, if necessary • Replace the encoder If the stepper motor is not supplied with current: <ul style="list-style-type: none"> • Check the stepper motor cable and replace, if necessary • Replace the stepper motor
2103	Error	X-axis stepper motor step losses: <ul style="list-style-type: none"> • Stiff mechanical movement or blockage 	<ul style="list-style-type: none"> • Remove the cause of the stiff mechanical movement or blockage
2121	Error	X-axis stepper motor: <ul style="list-style-type: none"> • Encoder plug (Sub-D, 9-pin) not connected or defective • Encoder defective 	<ul style="list-style-type: none"> • Check the connection of the encoder cable and replace, if necessary
2122	Information	Magnet wheel search timeout	<ul style="list-style-type: none"> • Check connection cables • Check stepper motor for stiff movement
2130	Error	X-axis stepper motor not responding	<ul style="list-style-type: none"> • Perform a software update • Replace the control
2152	Error	X-axis stepper motor over-current	<ul style="list-style-type: none"> • Replace the stepper motor
2153	Error	Excess voltage	<ul style="list-style-type: none"> • Check the mains voltage
2155	Error	X-axis stepper motor overload (I ² T): <ul style="list-style-type: none"> • Stepper motor not moving freely or blocked • Stepper motor defective • control defective 	<ul style="list-style-type: none"> • Remove the blockage or the cause of the stiff movement • Replace the stepper motor • Replace the control
2156	Error	X-axis stepper motor: <ul style="list-style-type: none"> • Stepper motor not moving freely • Stepper motor defective • control defective 	<ul style="list-style-type: none"> • Correct the cause of not moving freely • Replace the stepper motor • Replace the control

Code	Type	Possible causes	Remedial action
2162	Error	X-axis stepper motor disturbance (IDMA auto increment)	<ul style="list-style-type: none"> • Switch the machine off and on again
2171	Error	Watchdog	<ul style="list-style-type: none"> • Switch the machine off and on again • Perform a software update • Contact customer service
2172	Error	Stepper motor overvoltage: <ul style="list-style-type: none"> • Stepper motor card defective 	<ul style="list-style-type: none"> • Replace the control
2173	Error	X-axis stepper motor error	<ul style="list-style-type: none"> • Check the connection • Test stepper motor phases (R = 2.8Ω, high impedance to PE) • Replace the encoder • Replace the stepper motor • Replace the control
2174	Error	Software error	<ul style="list-style-type: none"> • Perform reset • Perform a software update • Contact customer service
2175	Error	Magnet wheel search	<ul style="list-style-type: none"> • Check the connection • Test stepper motor phases (R = 2.8Ω, high impedance to PE) • Replace the encoder • Replace the stepper motor • Replace the control
2177	Error	Stepper motor overload (I ² T)	<ul style="list-style-type: none"> • Remove the cause of the stiff movement or blockage • Replace the stepper motor • Replace the control
2178	Error	Encoder error	<ul style="list-style-type: none"> • Check the connection of the encoder cable and replace, if necessary • Replace the control
2179	Error	Current sensor: <ul style="list-style-type: none"> • Stepper motor card defective • control defective 	<ul style="list-style-type: none"> • Replace the control

Code	Type	Possible causes	Remedial action
2180	Error	Direction of rotation	<ul style="list-style-type: none"> • Replace the encoder • Check plug assignment and change, if necessary • Check wiring in machine distributor and change it, if necessary • Test stepper motor phases and check for correct value
2181	Error	Error in the reference run	<ul style="list-style-type: none"> • Replace the reference switch
2182	Error	Stepper motor current error	<ul style="list-style-type: none"> • Remove the blockage • Check the encoder cable and replace, if necessary • Replace the stepper motor
2183	Error	Stepper motor overcurrent	<ul style="list-style-type: none"> • Replace the sewing motor cable • Replace the stepper motor • Replace the control
2184	Error	Software error	<ul style="list-style-type: none"> • Perform reset • Perform a software update • Contact customer service
2185	Error	Stepper motor insulation error	<ul style="list-style-type: none"> • Check motor phase and PE for low-impedance connection • Replace the encoder • Replace the stepper motor
2186	Error	Software error	<ul style="list-style-type: none"> • Perform reset • Perform a software update • Contact customer service
2187	Error	Software error	<ul style="list-style-type: none"> • Perform reset • Perform a software update • Contact customer service
2188	Error	Software error	<ul style="list-style-type: none"> • Perform reset • Perform a software update • Contact customer service

Code	Type	Possible causes	Remedial action
2202	Error	Y-axis stepper motor: <ul style="list-style-type: none"> • Stepper motor not moving freely or blocked • Encoder cable not connected or defective • Stepper motor cable not connected or defective • Encoder defective • Stepper motor defective 	<ul style="list-style-type: none"> • Remove the cause of the stiff movement or blockage • Check the encoder cable and replace, if necessary • Replace the encoder <p>If the stepper motor is not supplied with current:</p> <ul style="list-style-type: none"> • Check the stepper motor cable and replace, if necessary • Replace the stepper motor
2203	Error	Y-axis stepper motor step losses: <ul style="list-style-type: none"> • Stiff mechanical movement or blockage 	<ul style="list-style-type: none"> • Remove the cause of the stiff mechanical movement or blockage
2221	Error	Y-axis stepper motor: <ul style="list-style-type: none"> • Encoder plug (Sub-D, 9-pin) not connected or defective • Encoder defective 	<ul style="list-style-type: none"> • Check the connection of the encoder cable and replace, if necessary
2222	Information	Magnet wheel search timeout	<ul style="list-style-type: none"> • Check connection cables • Check stepper motor for stiff movement
2230	Error	Y-axis stepper motor not responding	<ul style="list-style-type: none"> • Perform a software update • Replace the control
2252	Error	Y-axis stepper motor overcurrent	<ul style="list-style-type: none"> • Replace the stepper motor
2253	Error	Excess voltage	<ul style="list-style-type: none"> • Check the mains voltage
2255	Error	Y-axis stepper motor overload (I^2T): <ul style="list-style-type: none"> • Stepper motor not moving freely or blocked • Stepper motor defective • control defective 	<ul style="list-style-type: none"> • Remove the blockage or the cause of the stiff movement • Replace the stepper motor • Replace the control
2256	Error	Y-axis stepper motor: <ul style="list-style-type: none"> • Stepper motor not moving freely • Stepper motor defective • control defective 	<ul style="list-style-type: none"> • Correct the cause of not moving freely • Replace the stepper motor • Replace the control

Code	Type	Possible causes	Remedial action
2262	Error	Y-axis stepper motor disturbance (IDMA auto increment)	<ul style="list-style-type: none"> • Switch the machine off and on again
2271	Error	Watchdog	<ul style="list-style-type: none"> • Switch the machine off and on again • Perform a software update • Contact customer service
2272	Error	Stepper motor overvoltage: <ul style="list-style-type: none"> • Stepper motor card defective 	<ul style="list-style-type: none"> • Replace the control
2273	Error	Y-axis stepper motor error	<ul style="list-style-type: none"> • Check the connection • Test stepper motor phases (R = 2.8Ω, high impedance to PE) • Replace the encoder • Replace the stepper motor • Replace the control
2274	Error	Software error	<ul style="list-style-type: none"> • Perform reset • Perform a software update • Contact customer service
2275	Error	Magnet wheel search	<ul style="list-style-type: none"> • Check the connection • Test stepper motor phases (R = 2.8Ω, high impedance to PE) • Replace the encoder • Replace the stepper motor • Replace the control
2277	Error	Stepper motor overload (I ² T)	<ul style="list-style-type: none"> • Remove the cause of the stiff movement or blockage • Replace the stepper motor • Replace the control
2278	Error	Encoder error	<ul style="list-style-type: none"> • Check the connection of the encoder cable and replace, if necessary • Replace the control
2279	Error	Current sensor: <ul style="list-style-type: none"> • Stepper motor card defective • control defective 	<ul style="list-style-type: none"> • Replace the control

Code	Type	Possible causes	Remedial action
2280	Error	Direction of rotation	<ul style="list-style-type: none"> • Replace the encoder • Check plug assignment and change, if necessary • Check wiring in machine distributor and change it, if necessary • Test stepper motor phases and check for correct value
2281	Error	Error in the reference run	<ul style="list-style-type: none"> • Replace the reference switch
2282	Error	Stepper motor current error	<ul style="list-style-type: none"> • Remove the blockage • Check the encoder cable and replace, if necessary • Replace the stepper motor
2283	Error	Stepper motor overcurrent	<ul style="list-style-type: none"> • Replace the sewing motor cable • Replace the stepper motor • Replace the control
2284	Error	Software error	<ul style="list-style-type: none"> • Perform reset • Perform a software update • Contact customer service
2285	Error	Stepper motor insulation error	<ul style="list-style-type: none"> • Check motor phase and PE for low-impedance connection • Replace the encoder • Replace the stepper motor
2286	Error	Software error	<ul style="list-style-type: none"> • Perform reset • Perform a software update • Contact customer service
2287	Error	Software error	<ul style="list-style-type: none"> • Perform reset • Perform a software update • Contact customer service
2288	Error	Software error	<ul style="list-style-type: none"> • Perform reset • Perform a software update • Contact customer service

Code	Type	Possible causes	Remedial action
2302	Error	Z-axis stepper motor: <ul style="list-style-type: none"> • Stepper motor not moving freely or blocked • Encoder cable not connected or defective • Stepper motor cable not connected or defective • Encoder defective • Stepper motor defective 	<ul style="list-style-type: none"> • Remove the cause of the stiff movement or blockage • Check the encoder cable and replace, if necessary • Replace the encoder If the stepper motor is not supplied with current: <ul style="list-style-type: none"> • Check the stepper motor cable and replace, if necessary • Replace the stepper motor
2303	Error	Z-axis stepper motor step losses: <ul style="list-style-type: none"> • Stiff mechanical movement or blockage 	<ul style="list-style-type: none"> • Remove the cause of the stiff mechanical movement or blockage
2321	Error	Z-axis stepper motor: <ul style="list-style-type: none"> • Encoder plug (Sub-D, 9-pin) not connected or defective • Encoder defective 	<ul style="list-style-type: none"> • Check the connection of the encoder cable and replace, if necessary
2322	Information	Magnet wheel search timeout	<ul style="list-style-type: none"> • Check connection cables • Check stepper motor for stiff movement
2330	Error	Z-axis stepper motor not responding	<ul style="list-style-type: none"> • Perform a software update • Replace the control
2352	Error	Z-axis stepper motor overcurrent	<ul style="list-style-type: none"> • Replace the stepper motor
2353	Error	Excess voltage	<ul style="list-style-type: none"> • Check the mains voltage
2355	Error	Z-axis stepper motor overload (I ² T): <ul style="list-style-type: none"> • Stepper motor not moving freely or blocked • Stepper motor defective • control defective 	<ul style="list-style-type: none"> • Remove the blockage or the cause of the stiff movement • Replace the stepper motor • Replace the control
2356	Error	Z-axis stepper motor: <ul style="list-style-type: none"> • Stepper motor not moving freely • Stepper motor defective • control defective 	<ul style="list-style-type: none"> • Correct the cause of not moving freely • Replace the stepper motor • Replace the control

Code	Type	Possible causes	Remedial action
2362	Error	Z-axis stepper motor disturbance (IDMA auto increment)	<ul style="list-style-type: none"> • Switch the machine off and on again
2371	Error	Watchdog	<ul style="list-style-type: none"> • Switch the machine off and on again • Perform a software update • Contact customer service
2372	Error	Stepper motor overvoltage: <ul style="list-style-type: none"> • Stepper motor card defective 	<ul style="list-style-type: none"> • Replace the control
2373	Error	Z-axis stepper motor error	<ul style="list-style-type: none"> • Check the connection • Test stepper motor phases (R = 2.8Ω, high impedance to PE) • Replace the encoder • Replace the stepper motor • Replace the control
2374	Error	Software error	<ul style="list-style-type: none"> • Perform reset • Perform a software update • Contact customer service
2375	Error	Magnet wheel search	<ul style="list-style-type: none"> • Check the connection • Test stepper motor phases (R = 2.8Ω, high impedance to PE) • Replace the encoder • Replace the stepper motor • Replace the control
2377	Error	Stepper motor overload (I ² T)	<ul style="list-style-type: none"> • Remove the cause of the stiff movement or blockage • Replace the stepper motor • Replace the control
2378	Error	Encoder error	<ul style="list-style-type: none"> • Check the connection of the encoder cable and replace, if necessary • Replace the control
2379	Error	Current sensor: <ul style="list-style-type: none"> • Stepper motor card defective • control defective 	<ul style="list-style-type: none"> • Replace the control

Code	Type	Possible causes	Remedial action
2380	Error	Direction of rotation	<ul style="list-style-type: none"> • Replace the encoder • Check plug assignment and change, if necessary • Check wiring in machine distributor and change it, if necessary • Test stepper motor phases and check for correct value
2381	Error	Error in the reference run	<ul style="list-style-type: none"> • Replace the reference switch
2382	Error	Stepper motor current error	<ul style="list-style-type: none"> • Remove the blockage • Check the encoder cable and replace, if necessary • Replace the stepper motor
2383	Error	Stepper motor overcurrent	<ul style="list-style-type: none"> • Replace the sewing motor cable • Replace the stepper motor • Replace the control
2384	Error	Software error	<ul style="list-style-type: none"> • Perform reset • Perform a software update • Contact customer service
2385	Error	Stepper motor insulation error	<ul style="list-style-type: none"> • Check motor phase and PE for low-impedance connection • Replace the encoder • Replace the stepper motor
2386	Error	Software error	<ul style="list-style-type: none"> • Perform reset • Perform a software update • Contact customer service
2387	Error	Software error	<ul style="list-style-type: none"> • Perform reset • Perform a software update • Contact customer service
2388	Error	Software error	<ul style="list-style-type: none"> • Perform reset • Perform a software update • Contact customer service

Code	Type	Possible causes	Remedial action
2402	Error	U-axis stepper motor: <ul style="list-style-type: none"> • Stepper motor not moving freely or blocked • Encoder cable not connected or defective • Stepper motor cable not connected or defective • Encoder defective • Stepper motor defective 	<ul style="list-style-type: none"> • Remove the cause of the stiff movement or blockage • Check the encoder cable and replace, if necessary • Replace the encoder If the stepper motor is not supplied with current: <ul style="list-style-type: none"> • Check the stepper motor cable and replace, if necessary • Replace the stepper motor
2403	Error	U-axis stepper motor step losses: <ul style="list-style-type: none"> • Stiff mechanical movement or blockage 	<ul style="list-style-type: none"> • Remove the cause of the stiff mechanical movement or blockage
2421	Error	U-axis stepper motor: <ul style="list-style-type: none"> • Encoder plug (Sub-D, 9-pin) not connected or defective • Encoder defective 	<ul style="list-style-type: none"> • Check the connection of the encoder cable and replace, if necessary
2422	Information	Magnet wheel search timeout	<ul style="list-style-type: none"> • Check connection cables • Check stepper motor for stiff movement
2430	Error	U-axis stepper motor not responding	<ul style="list-style-type: none"> • Perform a software update • Replace the control
2452	Error	U-axis stepper motor over current	<ul style="list-style-type: none"> • Replace the stepper motor
2453	Error	Excess voltage	<ul style="list-style-type: none"> • Check the mains voltage
2455	Error	U-axis stepper motor overload (I ² T): <ul style="list-style-type: none"> • Stepper motor not moving freely or blocked • Stepper motor defective • control defective 	<ul style="list-style-type: none"> • Remove the blockage or the cause of the stiff movement • Replace the stepper motor • Replace the control
2456	Error	U-axis stepper motor: <ul style="list-style-type: none"> • Stepper motor not moving freely • Stepper motor defective • control defective 	<ul style="list-style-type: none"> • Correct the cause of not moving freely • Replace the stepper motor • Replace the control



Code	Type	Possible causes	Remedial action
2462	Error	<ul style="list-style-type: none"> U-axis stepper motor disturbance (IDMA auto increment) 	<ul style="list-style-type: none"> Switch the machine off and on again
2471	Error	<ul style="list-style-type: none"> Watchdog 	<ul style="list-style-type: none"> Switch the machine off and on again Perform a software update Contact customer service
2472	Error	Stepper motor overvoltage: <ul style="list-style-type: none"> Stepper motor card defective 	<ul style="list-style-type: none"> Replace the control
2473	Error	U-axis stepper motor over current error	<ul style="list-style-type: none"> Check the connection Test stepper motor phases (R = 2.8Ω, high impedance to PE) Replace the encoder Replace the stepper motor Replace the control
2474	Error	Software error	<ul style="list-style-type: none"> Perform reset Perform a software update Contact customer service
2475	Error	Magnet wheel search	<ul style="list-style-type: none"> Check the connection Test stepper motor phases (R = 2.8Ω, high impedance to PE) Replace the encoder Replace the stepper motor Replace the control
2477	Error	Stepper motor overload (I ² T)	<ul style="list-style-type: none"> Remove the cause of the stiff movement or blockage Replace the stepper motor Replace the control
2478	Error	Encoder error	<ul style="list-style-type: none"> Check the connection of the encoder cable and replace, if necessary Replace the control
2479	Error	Current sensor: <ul style="list-style-type: none"> Stepper motor card defective control defective 	<ul style="list-style-type: none"> Replace the control







Code	Type	Possible causes	Remedial action
2480	Error	Direction of rotation	<ul style="list-style-type: none"> • Replace the encoder • Check plug assignment and change, if necessary • Check wiring in machine distributor and change it, if necessary • Test stepper motor phases and check for correct value
2481	Error	Error in the reference run	<ul style="list-style-type: none"> • Replace the reference switch
2482	Error	Stepper motor current error	<ul style="list-style-type: none"> • Remove the blockage • Check the encoder cable and replace, if necessary • Replace the stepper motor
2483	Error	Stepper motor overcurrent	<ul style="list-style-type: none"> • Replace the sewing motor cable • Replace the stepper motor • Replace the control
2484	Error	Software error	<ul style="list-style-type: none"> • Perform reset • Perform a software update • Contact customer service
2485	Error	Stepper motor insulation error	<ul style="list-style-type: none"> • Check motor phase and PE for low-impedance connection • Replace the encoder • Replace the stepper motor
2486	Error	Software error	<ul style="list-style-type: none"> • Perform reset • Perform a software update • Contact customer service
2487	Error	Software error	<ul style="list-style-type: none"> • Perform reset • Perform a software update • Contact customer service
2488	Error	Software error	<ul style="list-style-type: none"> • Perform reset • Perform a software update • Contact customer service

Code	Type	Possible causes	Remedial action
2901	Error	Referencing timeout	<ul style="list-style-type: none"> • Switch the machine off and on again • Check the clamping of the stepper motor
3010	Error	control: 100 V voltage error	<ul style="list-style-type: none"> • Check the connections • Replace the control
3011	Error	control: 100 V voltage error	<ul style="list-style-type: none"> • Check the connections • Replace the control
3012	Error	control: 100 V voltage error (I ² T)	<ul style="list-style-type: none"> • Switch the machine off and on again • Check the connections • Replace the control
3020	Error	Short circuit in 24 V input or output	<ul style="list-style-type: none"> • Check the connections • Replace the control
3021	Error	Short circuit in 24 V input or output	<ul style="list-style-type: none"> • Check the connections • Replace the control
3022	Error	Short circuit in 24 V input or output (I ² T)	<ul style="list-style-type: none"> • Switch the machine off and on again • Check the connections • Replace the control
3030	Error	Sewing motor phase error	<ul style="list-style-type: none"> • Test sewing motor phases (R = 2.8Ω, high impedance to PE) • Replace the encoder • Replace the sewing motor • Replace the control
3104	Warning	<ul style="list-style-type: none"> • Pedal not in rest position • Setpoint device defective 	<ul style="list-style-type: none"> • Do not step on the Pedal when starting up the machine • Replace the setpoint device
4440 – 4459	Error	OP3000 control panel: Internal error	<ul style="list-style-type: none"> • Switch the machine off and on again • Perform a software update • Replace the control panel
5503	Error	Software too old	<ul style="list-style-type: none"> • Perform a software update, then perform a reset (📖 S. 64), (📖 S. 106)

Code	Type	Possible causes	Remedial action
6000 – 6299	Error	Internal error	<ul style="list-style-type: none"> • Switch the machine off and on again • Perform a software update • Contact customer service
6351 – 6354	Error	control defective (I ² C)	<ul style="list-style-type: none"> • Replace the control
6360 – 6367	Error	Machine ID error	<ul style="list-style-type: none"> • Check the machine ID plug • If necessary, replace the machine ID
6400 – 6999	Error	Internal error	<ul style="list-style-type: none"> • Switch the machine off and on again • Perform a software update • Contact customer service
7551 – 7659	Error	<ul style="list-style-type: none"> • Internal error • Cable disturbance • Cables to the control panel Interface defective 	<ul style="list-style-type: none"> • Switch the machine off and on again • Eliminate source of disturbance • Perform a software update • Replace the cable • Contact customer service
9910	Error	Tilt sensor: <ul style="list-style-type: none"> • Machine head is tilted over • Tilt sensor not fitted or defective 	<ul style="list-style-type: none"> • Erecting the machine head • Fit or replace tilt sensor

11.3 Errors in sewing process

Meaning	Possible causes	Remedial action
Thread breakage	<ul style="list-style-type: none"> The needle and hook threads are not threaded correctly 	<ul style="list-style-type: none"> Check threading path ( <i>Operating Instructions, Operation</i>)
	<ul style="list-style-type: none"> Needle is bent or sharp-edged Needle is not inserted correctly into the needle bar 	<ul style="list-style-type: none"> Replace the needle Insert the needle into the needle bar
	<ul style="list-style-type: none"> The needle used is unsuitable 	<ul style="list-style-type: none"> Use recommended thread ( <i>Operating Instructions</i>)
	<ul style="list-style-type: none"> Thread tensions are too tight for the thread used 	<ul style="list-style-type: none"> Check thread tensions ( <i>Operating Instructions, Operation</i>)
	<ul style="list-style-type: none"> Thread-guiding parts such as thread tube, thread guide or thread-takeup disk are sharp-edged 	<ul style="list-style-type: none"> Check the thread path
	<ul style="list-style-type: none"> Throat plate, hook or spread have been damaged by the needle 	<ul style="list-style-type: none"> Have parts reworked by qualified specialists

Meaning	Possible causes	Remedial action
Missing stitches	<ul style="list-style-type: none"> • The needle and hook threads are not threaded correctly 	<ul style="list-style-type: none"> • Check threading path ( <i>Operating Instructions, Operation</i>)
	<ul style="list-style-type: none"> • Needle is blunt or bent • Needle is not inserted correctly into the needle bar 	<ul style="list-style-type: none"> • Replace the needle • Insert the needle into the needle bar
	<ul style="list-style-type: none"> • The needle thickness used is unsuitable 	<ul style="list-style-type: none"> • Use recommended needle thickness ( <i>S. 161</i>)
	<ul style="list-style-type: none"> • The thread reel holder is installed incorrectly 	<ul style="list-style-type: none"> • Check thread reel holder ( <i>Operating Instructions, Operation</i>)
	<ul style="list-style-type: none"> • Thread tensions are too tight 	<ul style="list-style-type: none"> • Check thread tensions ( <i>Operating Instructions, Operation</i>)
	<ul style="list-style-type: none"> • Sewing material is not held correctly 	<ul style="list-style-type: none"> • Check clamping pressure ( <i>Service Instructions</i>)
	<ul style="list-style-type: none"> • The loop stroke was not corrected when changing the zigzag stitch width 	<ul style="list-style-type: none"> • Adjust the loop stroke ( <i>Service Instructions</i>)
	<ul style="list-style-type: none"> • Incorrect parts used for the desired sewing equipment 	<ul style="list-style-type: none"> • Check the parts based on the equipment sheet
	<ul style="list-style-type: none"> • Throat plate, hook or spread have been damaged by the needle 	<ul style="list-style-type: none"> • Have parts reworked by qualified specialists

Meaning	Possible causes	Remedial action
Loose stitches	<ul style="list-style-type: none"> • Thread tensions are not adjusted to the sewing material, the sewing material thickness or the thread used 	<ul style="list-style-type: none"> • Check thread tensions
	<ul style="list-style-type: none"> • The needle and hook threads are not threaded correctly 	<ul style="list-style-type: none"> • Check threading path ( <i>Operating Instructions, Operation</i>)
Needle breakage	<ul style="list-style-type: none"> • Needle thickness is unsuitable for the sewing material or the thread 	<ul style="list-style-type: none"> • Use recommended needle
Seam beginning not secure	<ul style="list-style-type: none"> • Residual tension is too tight for the needle thread 	<ul style="list-style-type: none"> • Adjust residual tension

12 Technical data

Noise emission

Workplace-specific emission value as per DIN EN ISO 10821:

$L_C = 79$ dB (A) at

- Stitch length: 3.0 mm
- Number of stitches: 2900 rpm
- Sewing material: 2-layer material G1 DIN 23328

12.1 Data and parameters

Technical data	Unit	650-10
Machine type		Special sewing machine
Stitch type		Lockstitch 301
Hook type		Horizontal hook, oil-free
Number of needles		1
Needle system		134-35
Needle thickness	[Nm]	70 – 100
Thread strength	[Nm]	max. 50 / 3
Stitch length	[mm]	1.0 – 4.0
Max. speed	[min ⁻¹]	4000
Clearance under the raised sewing foot	[mm]	max. 12
Sewing Material Thickness	[mm]	max. 4
Mains voltage	[V]	230
Mains frequency	[Hz]	50
Table height	[mm]	750 – 900
Length, width, height	[mm]	750/1320/1490
Weight	[kg]	95

12.2 Requirements for trouble-free operation

Compressed air quality must be ensured in accordance with ISO 8573-1: 2010 [7:4:4].

Fig. 92: Dimensions for manufacturing a table top

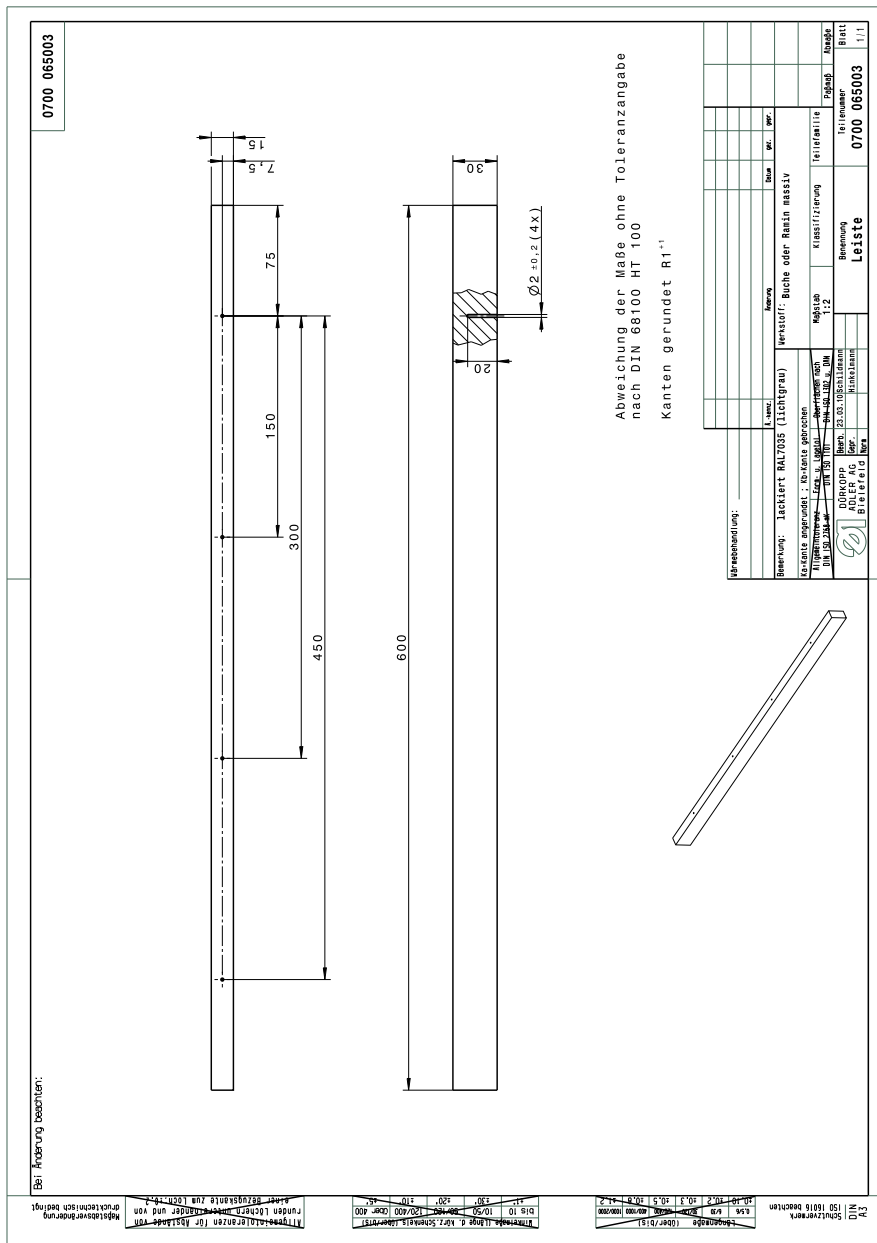

13.2 Wiring diagram

Fig. 93: Wiring diagram

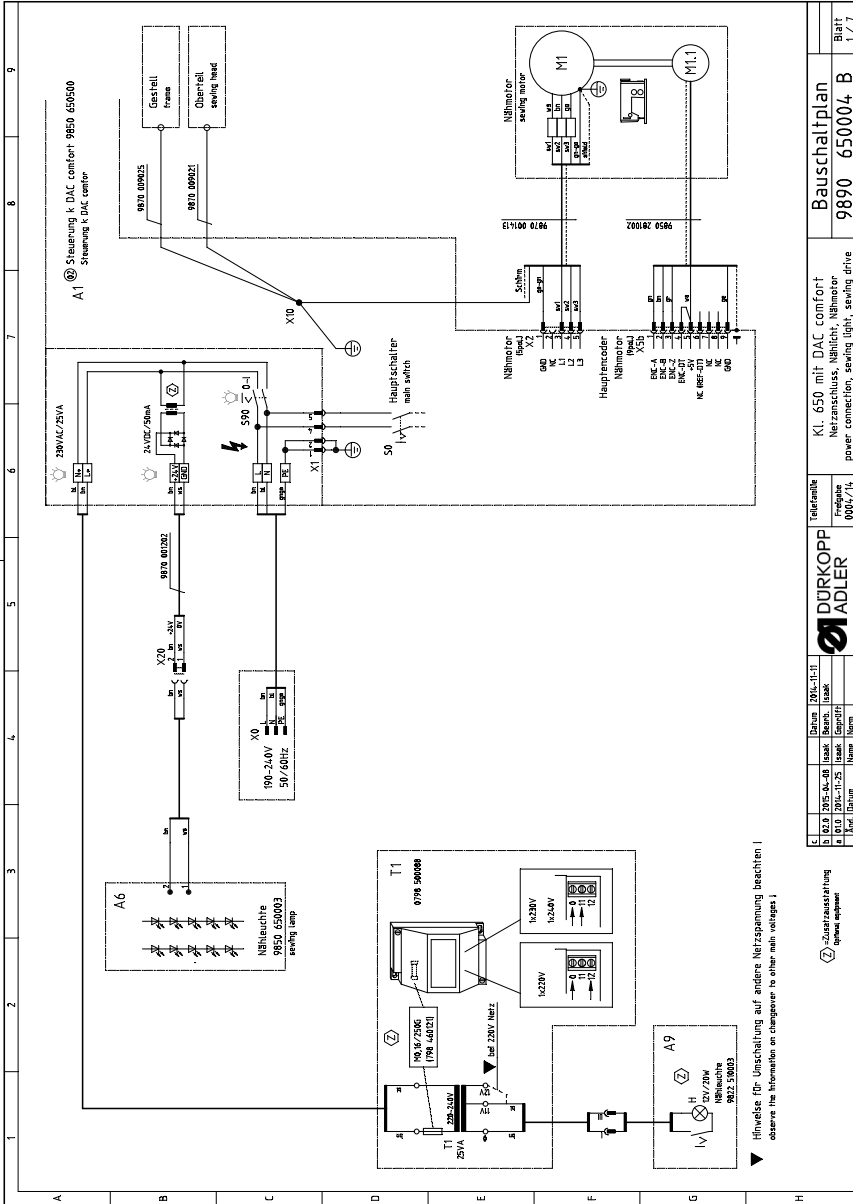

▼ Hinweise für Umschaltung auf andere Netzspannung beachten!
observe the information on changeover for other main voltages!

1	2	3	4	5	6	7	8	9
<p>DÜRKOPP ADLER</p> <p>Kl. 650 mit DAC comfort Netzanschluss, Nähnicht, Nähmotor power connection, sewing light, sewing drive</p> <p>Bauschaltplan 9890 650004 B Blatt 1 / 7</p>								

Fig. 94: Wiring diagram

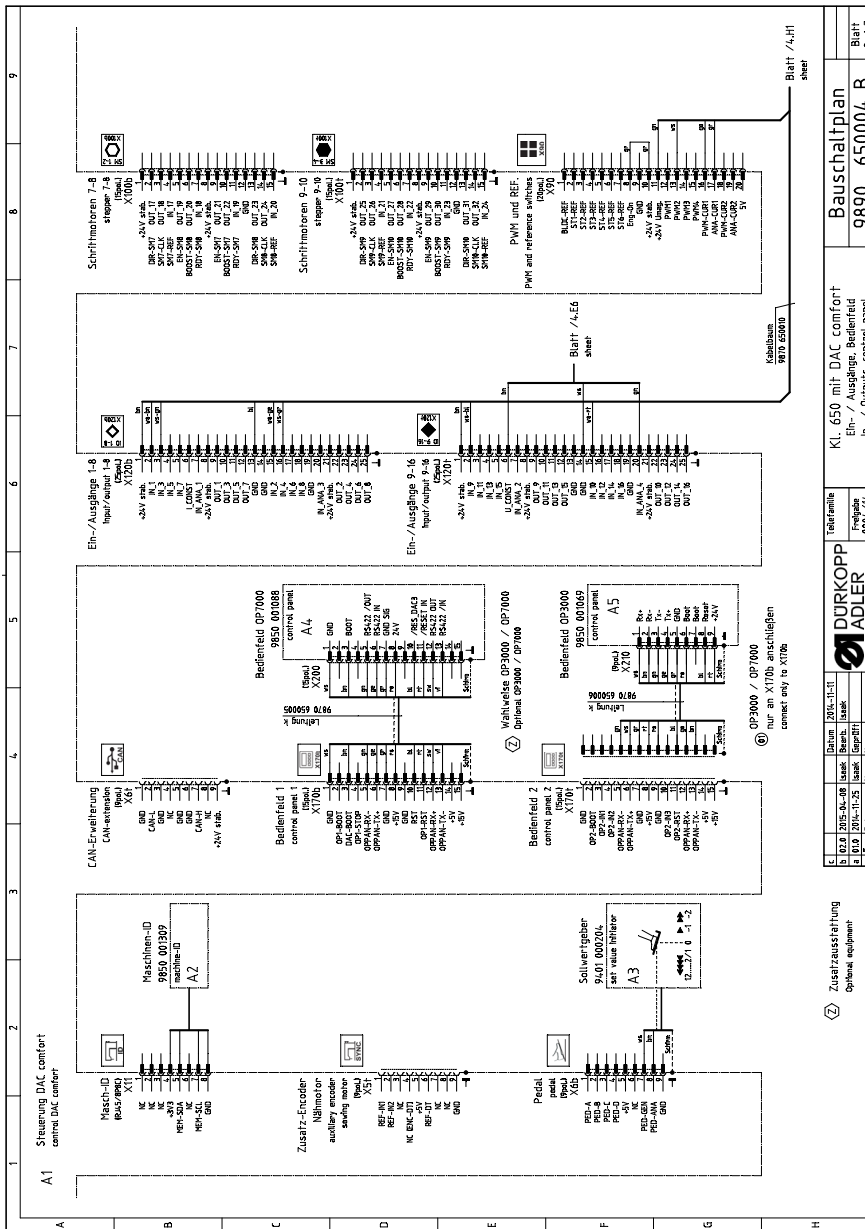

Blatt /4.H1 sheet		Blatt 2 / 7	
Bauschaltplan 9890 650004 B		Blatt 2 / 7	
Ein- / Ausgänge, Bedienfeld In- / Outputs, control panel		Blatt 2 / 7	
Freigabe 000k/7k		Blatt 2 / 7	
DÜRKOPP ADLER		Blatt 2 / 7	
Teilname 9850 001069		Blatt 2 / 7	
Name		Blatt 2 / 7	
Date		Blatt 2 / 7	
Rev		Blatt 2 / 7	
Zusatzanfertigung Optional equipment		Blatt 2 / 7	

Fig. 95: Wiring diagram

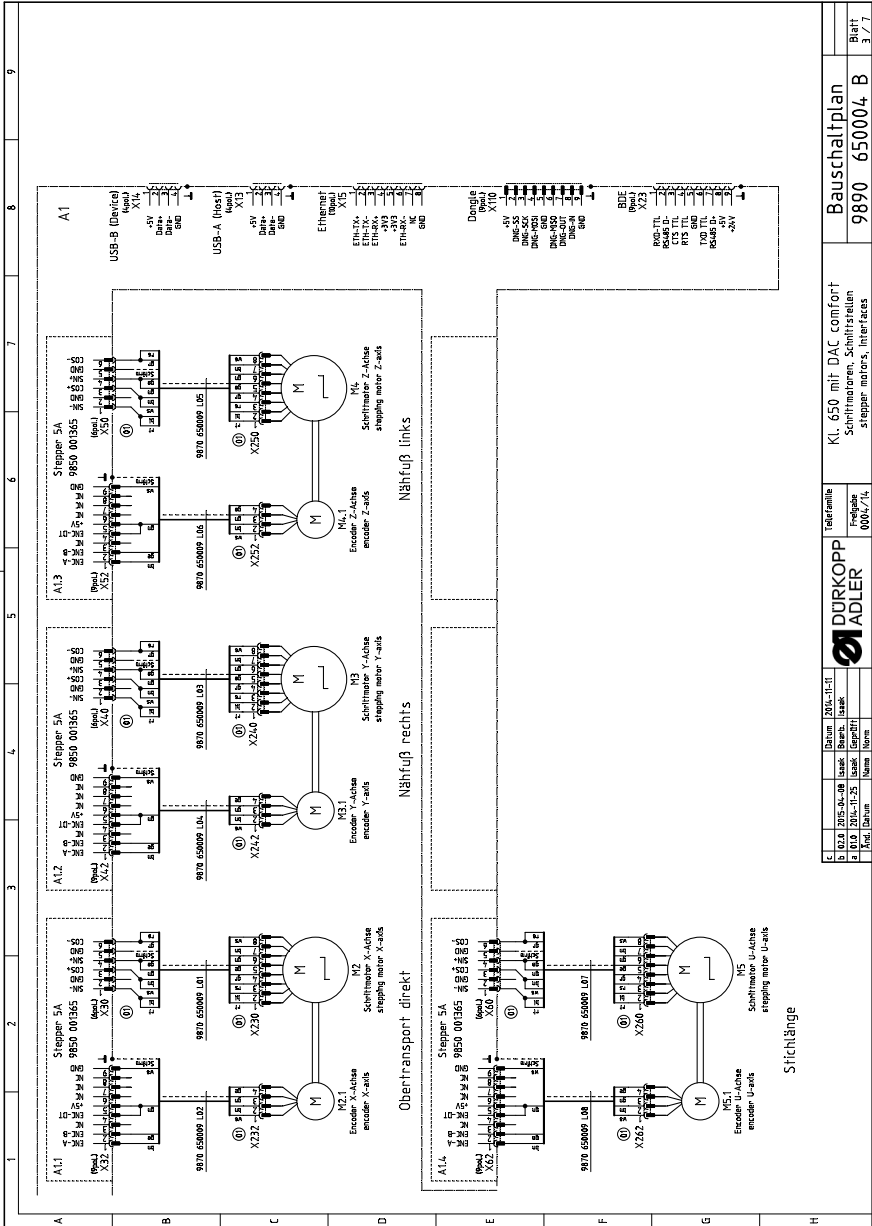

Datei		Datum		Zurück		10/11-11		Telefon		Bauschaltplan		Blatt	
1	02.0	2015-04-09	10:00	10:00	10:00	10:00	10:00	10:00	10:00	10:00	9890_650004_B	3/7	7
2	03.0	2015-04-09	10:00	10:00	10:00	10:00	10:00	10:00	10:00	10:00	Kl. 650 mit DAC comfort	3/7	7
3	04.0	2015-11-25	10:00	10:00	10:00	10:00	10:00	10:00	10:00	10:00	Schrittmotoren, Schnittstellen	3/7	7
4	05.0	2015-11-25	10:00	10:00	10:00	10:00	10:00	10:00	10:00	10:00	stepper motors, interfaces	3/7	7
5	06.0	2015-11-25	10:00	10:00	10:00	10:00	10:00	10:00	10:00	10:00	stepper motors, interfaces	3/7	7

Fig. 96: Wiring diagram

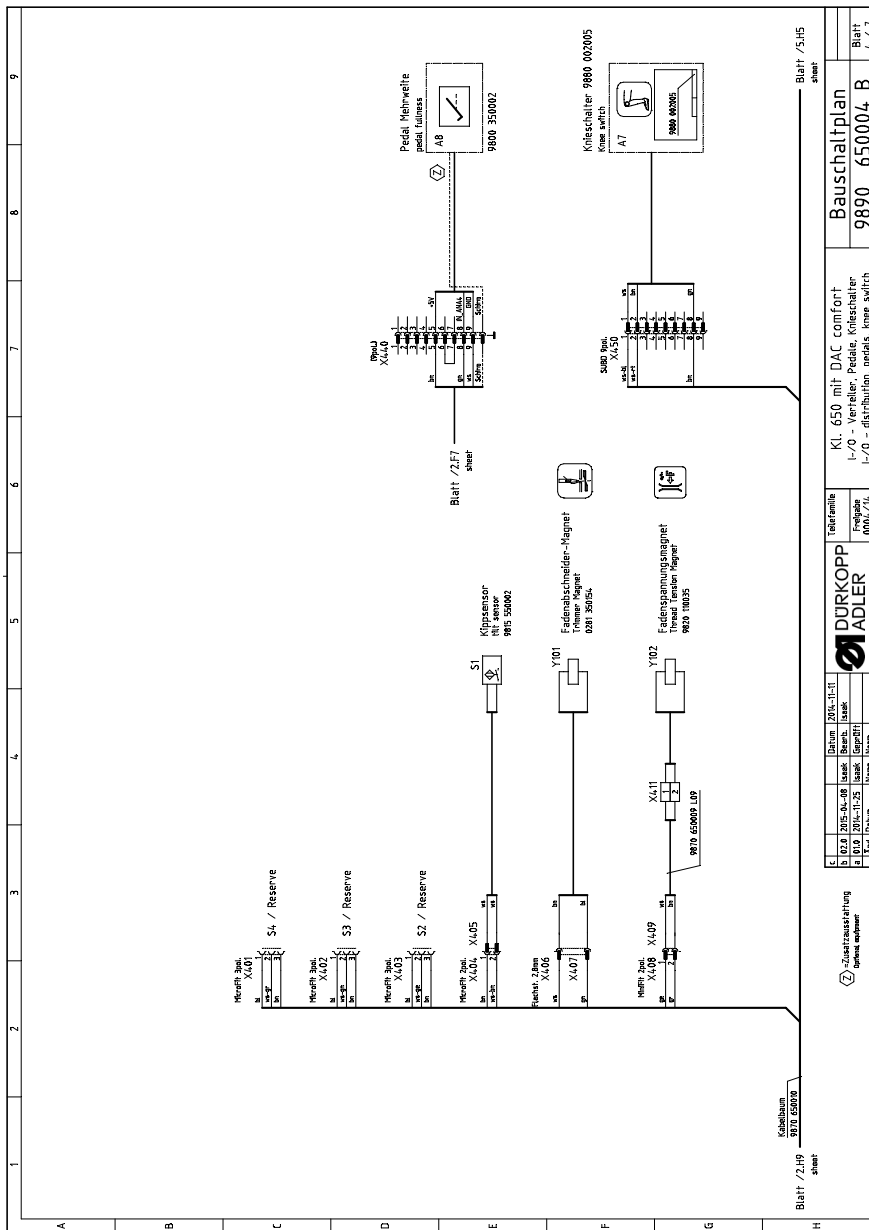

Blatt / 2/19 sheet		Blatt / 3/15 sheet		Blatt / 4/17 sheet	
Scheibbaum 9870 650070		Klappenschalter 986 002005		Bauschaltplan 9890 650004 B	
Zusammenhang siehe oben		Teilermäße Freigabe 000L/1L		Blatt / 4/17	
DÜRKOPP ADLER		KL. 650 mit DAC comfort l-/o - Verteiler, Pedale, Klappenschalter l-/o - distribution, pedals, knee switch			
2000-11-11 2005-01-09 2010-11-25 2012-01-25 Name: _____ Unters: _____					

Fig. 98: Wiring diagram

1	2	3	4	5	6	7	8	9
A	B	C	D	E	F	G	H	
kurzzeichen	Teilenummer	Benennung	denomination	Typ	Bemerkung			
A1	9850 650500	Steuerung k	control	COMFORT; TYP: 11100				
A2	9850 001355	USB-Speicherstick	USB memory stick	Softw. DAC comfort				
A3	9850 001309	Maschinen ID	machine ID					
A4	9850 001088	Sollwertgeber	actuator					
A5	9850 001069	Bedienfeld k	control panel	OP7000				
A6	9850 650003	Bedienfeld k	control panel	OP3000				
A7	9880 002005	Leiterplatte k	PCB cpl.	15-LED Nähleuchte				
A8	9880 350002	Knieschalter	knee switch	SWG-2	Pedal Mehrweite			
A9	9822 510003	Sollwertgeber	actuator	12V/ZOW Halogen	(on request / auf Wunsch)			
M1.1	9850 281002	Nähleuchte	sewing light					
M2	9800 580033	Encoder k	encoder cpl.					
M2.1	0580 490194	Stepper X-Achse	stepper x-axis	Obertransport	(nur montiert lieferbar / only mounted available)			
M3	9800 580042	Encoder X-Achse	encoder cpl.					
M3.1	0580 490194	Stepper Y-Achse	stepper x-axis	Nähfuß rechts	(nur montiert lieferbar / only mounted available)			
M4	9800 580042	Encoder Y-Achse	encoder cpl.					
M4.1	0580 490194	Stepper Z-Achse	stepper x-axis	Nähfuß links	(nur montiert lieferbar / only mounted available)			
M5	9800 580033	Encoder Z-Achse	encoder cpl.					
M5.1	0580 490194	Stepper U-Achse	stepper x-axis	Obertransport	(nur montiert lieferbar / only mounted available)			
S1	9815 550002	Encoder U-Achse	encoder cpl.					
T1	0798 500088	Schalter, Magnet k	magnetic switch		Kippensor			
X0	9825 190104	Trafo, Nählicht	transf. sewing light					
Y101	0281 350154	Netzstecker	mains plug	230V AC / 12V AC	(on request / auf Wunsch)			
Y102	9820 110035	FA-Magnet	trimmer solenoid	Schuko (DE)	(on request / auf Wunsch)			
		FS-Magnet	thread tension solenoid					
			Teilenummer	Kl. 650 mit DAC comfort		Bauschaltplan		Blatt
Datum: 2006-10-11 Zeichner: M... Bearbeiter: M...			Freigabe	Teilerteile		9890 650004 B		6 / 7
Name: M... Nachname: M...			0006,7/14	partis list				

DÜRKOPP ADLER GmbH

Potsdamer Straße 190

33719 Bielefeld

GERMANY

Phone +49 (0) 521 / 925-00

E-mail service@duerkopp-adler.com

www.duerkopp-adler.com

