

650-10

Service Instructions



**IMPORTANT**  
**READ CAREFULLY BEFORE USE**  
**KEEP FOR FUTURE REFERENCE**

All rights reserved.

Property of Dürkopp Adler GmbH and protected by copyright. Any reuse of these contents, including extracts, is prohibited without the prior written approval of Dürkopp Adler GmbH.

Copyright © Dürkopp Adler GmbH 2023

<b>1</b>	<b>About these instructions .....</b>	<b>5</b>
1.1	For whom are these instructions intended?.....	5
1.2	Representation conventions – symbols and characters .....	5
1.3	Other documents .....	7
1.4	Liability.....	7
<b>2</b>	<b>Safety .....</b>	<b>9</b>
2.1	Basic safety instructions .....	9
2.2	Signal words and symbols used in warnings.....	10
<b>3</b>	<b>Working basis .....</b>	<b>13</b>
3.1	Order of the adjustments .....	13
3.2	Laying the cables.....	13
3.3	Disassembling the covers.....	14
3.3.1	Tilting and re-erecting the machine head .....	15
3.3.2	Disassembling and assembling the head cover .....	16
3.3.3	Disassembling and assembling the rear machine arm cover .....	17
3.3.4	Disassembling and assembling the sewing material support surface and column cover .....	18
3.3.5	Disassembling and assembling the throat plate .....	19
3.4	Flats on shafts .....	20
3.5	Locking the machine in place .....	20
<b>4</b>	<b>Position of the hook and needle .....</b>	<b>23</b>
4.1	Adjusting looping stroke and hook side clearance .....	24
4.2	Adjusting the needle bar height .....	25
4.3	Adjusting the thread passage on the middle section holder .....	26
4.4	Adjusting the throat plate .....	27
<b>5</b>	<b>Adjusting the thread trimmer .....</b>	<b>28</b>
5.1	Adjusting the control cam .....	28
5.1.1	Adjusting the control cam position.....	28
5.1.2	Adjusting the distance between control cam and roller .....	29
5.2	Replacing and adjusting the thread-pulling knife .....	31
5.3	Changing the counter blade .....	32
5.4	Adjusting the counter blade and cutting pressure .....	32
5.5	Adjusting the path of the thread-pulling knife .....	34
<b>6</b>	<b>Adjusting the presser foot.....</b>	<b>35</b>
<b>7</b>	<b>Toothed belt.....</b>	<b>36</b>
7.1	Adjusting the toothed belt between upper and lower shaft.....	36
7.2	Adjusting the toothed belt for the hook drive .....	37
<b>8</b>	<b>Upper conveyor belts (old system).....</b>	<b>39</b>
8.1	Replacing the top conveyor belts .....	39
8.2	Adjusting the top conveyor belts.....	40
<b>9</b>	<b>Upper conveyor belts (new system) .....</b>	<b>42</b>
9.1	Replacing the top conveyor belts .....	42
9.2	Adjusting the top conveyor belts.....	43

<b>10</b>	<b>Bottom conveyor belts.....</b>	<b>46</b>
10.1	Replacing the bottom conveyor belts .....	46
10.2	Adjusting the bottom conveyor belts.....	47
10.3	Replacing the gear rims.....	48
<b>11</b>	<b>Checking the sewing foot lifting gear.....</b>	<b>49</b>
<b>12</b>	<b>Disassembling and assembling the electric thread tension</b>	<b>52</b>
12.1	Changing the thread tensioning spring.....	54
12.2	Adjusting the spring tension .....	57
12.3	Adjusting the spring travel .....	58
12.4	Adjusting the needle thread regulator.....	59
<b>13</b>	<b>Winder .....</b>	<b>60</b>
13.1	Adjusting the bobbin filling quantity .....	60
13.2	Adjusting the winding form .....	61
13.3	Adjusting the winding tension .....	62
<b>14</b>	<b>Programming (OP3000).....</b>	<b>63</b>
14.1	Calling up the Technician level.....	63
14.2	Menu items at the Technician level .....	65
14.3	Menu item <i>Default Program</i> .....	69
14.4	Menu item <i>Machine config</i> .....	71
14.4.1	Sub-item <i>Start Tack</i> .....	71
14.4.2	Sub-item <i>End Tack</i> .....	71
14.4.3	Sub-item <i>Thread Trim</i> .....	72
14.4.4	Sub-item <i>Speed</i> .....	72
14.4.5	Sub-item <i>Stop Positions</i> .....	73
14.4.6	Sub-item <i>Foot</i> .....	74
14.4.7	Sub-item <i>Thr. Tens.</i> .....	74
14.4.8	Sub-item <i>Pedal</i> .....	75
14.5	Menu item <i>User config</i> .....	75
14.6	Menu item <i>Service</i> .....	76
14.6.1	Sub-item <i>Multitest</i> .....	76
14.6.2	Menu item <i>Calibration</i> .....	80
14.6.3	Sub-item <i>Reset</i> .....	85
14.6.4	Sub-item <i>Data Transfer</i> .....	86
14.7	Testing the functionality of the keys on the control panel.....	87
14.8	Performing a software update .....	88
<b>15</b>	<b>Programming (OP7000).....</b>	<b>91</b>
15.1	Calling up the Technician level.....	91
15.2	Menu items at the Technician level .....	92
15.3	Menu item <i>Default Program Parameters</i> .....	96
15.4	Menu item <i>Machine Configuration</i> .....	98
15.4.1	Sub-items <i>Backtack At Start/End</i> .....	98
15.4.2	Sub-item <i>Thread Trimmer</i> .....	99
15.4.3	Sub-item <i>Speed</i> .....	99
15.4.4	Sub-item <i>Stop Positions</i> .....	100
15.4.5	Sub-item <i>Foot</i> .....	100
15.5	Menu item <i>User configuration</i> .....	101
15.6	Menu item <i>USB Operations</i> .....	102


---

15.7	Menu item <i>Calibration</i> .....	103
15.7.1	Sub-item <i>Adjust Flat Sewing Top</i> .....	103
15.7.2	Sub-item <i>Feet Difference Calibration</i> .....	104
15.7.3	Sub-item <i>Thread Tension Calibration</i> .....	104
15.8	Menu item <i>Reset Operations</i> .....	107
15.8.1	Sub-item <i>Reset All</i> .....	107
15.8.2	Sub-item <i>Reset Sewing Programs</i> .....	108
15.9	Menu item <i>Test Input / Output</i> .....	108
15.10	Performing a software update .....	109
<b>16</b>	<b>Maintenance</b> .....	<b>115</b>
16.1	Cleaning .....	116
16.2	Lubricating .....	117
16.3	Parts list.....	118
<b>17</b>	<b>Decommissioning</b> .....	<b>119</b>
<b>18</b>	<b>Disposal</b> .....	<b>121</b>
<b>19</b>	<b>Troubleshooting</b> .....	<b>123</b>
19.1	Customer Service .....	123
19.2	Messages of the software.....	124
19.3	Errors in sewing process .....	136
<b>20</b>	<b>Technical data</b> .....	<b>139</b>
20.1	Data and characteristic values .....	139
20.2	Requirements for fault-free operation.....	139
<b>21</b>	<b>Appendix</b> .....	<b>141</b>



## 1 About these instructions

These instructions have been prepared with utmost care. They contain information and notes intended to ensure long-term and reliable operation.


Should you notice any discrepancies or if you have improvement requests, then we would be glad to receive your feedback through **Customer Service** ( p. 123).

Consider these instructions as part of the product and keep it easily accessible.

### 1.1 For whom are these instructions intended?

These instructions are intended for:

- **Specialists:**  
This group has the appropriate technical training for performing maintenance or repairing malfunctions.

With regard to minimum qualification and other requirements to be met by personnel, please also follow the chapter **Safety** ( p. 9).

### 1.2 Representation conventions – symbols and characters

Various information in these instructions is represented or highlighted by the following characters in order to facilitate easy and quick understanding:



#### **Proper setting**

Specifies proper setting.



#### **Disturbances**

Specifies the disturbances that can occur from an incorrect adjustment.



#### **Cover**

Specifies which covers must be disassembled in order to access the components to be set.



**Steps to be performed when operating the machine (sewing and equipping)**



**Steps to be performed for service, maintenance, and installation**



**Steps to be performed via the software control panel**

**The individual steps are numbered:**

1. First step
  2. Second step
  - ...
- The steps must always be followed in the specified order.
- Lists are marked by bullet points.



**Result of performing an operation**

Change to the machine or on the display/control panel.



**Important**

Special attention must be paid to this point when performing a step.



**Information**

Additional information, e.g. on alternative operating options.



**Order**


Specifies the work to be performed before or after an adjustment.

**References**



Reference to another section in these instructions.

**Safety**

Important warnings for the user of the machine are specifically marked. Since safety is of particular importance, hazard symbols, levels of danger and their signal words are described separately in the chapter **Safety** ( p. 9).

**Location information**

If no other clear location information is used in a figure, indications of **right** or **left** are always from the user's point of view.



### 1.3 Other documents

The machine includes components from other manufacturers. Each manufacturer has performed a hazard assessment for these purchased parts and confirmed their design compliance with applicable European and national regulations. The proper use of the built-in components is described in the corresponding manufacturer's instructions.

### 1.4 Liability

All information and notes in these instructions have been compiled in accordance with the latest technology and the applicable standards and regulations.

Dürkopp Adler cannot be held liable for any damage resulting from:

- Breakage and transport damages
- Failure to observe these instructions
- Improper use
- Unauthorized modifications to the machine
- Use of untrained personnel
- Use of unapproved parts

#### Transport

Dürkopp Adler cannot be held liable for breakage and transport damages. Inspect the delivery immediately upon receiving it. Report any damage to the last transport manager. This also applies if the packaging is not damaged.

Leave machines, equipment and packaging material in the condition in which they were found when the damage was discovered. This will ensure any claims against the transport company.

Report all other complaints to Dürkopp Adler immediately after receiving the product.



## 2 Safety

This chapter contains basic information for your safety. Read the instructions carefully before setting up or operating the machine. Make sure to follow the information included in the safety instructions. Failure to do so can result in serious injury and property damage.



### 2.1 Basic safety instructions

The machine may only be used as described in these instructions.

These instructions must be available at the machine's location at all times.

Work on live components and equipment is prohibited. Exceptions are defined in the DIN VDE 0105.

For the following work, switch off the machine at the main switch or disconnect the power plug:

- Replacing the needle or other sewing tools
- Leaving the workstation
- Performing maintenance work and repairs
- Threading

Missing or faulty parts could impair safety and damage the machine. Only use original parts from the manufacturer.

**Transport** Use a lifting carriage or stacker to transport the machine. Raise the machine max. 20 mm and secure it to prevent it from slipping off.

**Setup** The connection cable must have a power plug approved in the relevant country. The power plug may only be assembled to the connection cable by qualified specialists.

**Obligations of the operator** Follow the country-specific safety and accident prevention regulations and the legal regulations concerning industrial safety and the protection of the environment.

All the warnings and safety signs on the machine must always be in legible condition. Do not remove!

Missing or damaged warnings and safety signs must be replaced immediately.

**Requirements to be met by the personnel**

Only qualified specialists may:

- Setting up the machine/putting the machine into operation
- Performing maintenance work and repairs
- Performing work on electrical equipment

Only authorized persons may work on the machine and must first have understood these instructions.

- Operation** Check the machine during operating for any externally visible damage. Stop working if you notice any changes to the machine. Report any changes to your supervisor. Do not use a damaged machine any further.
- Safety equipment** Safety equipment should not be disassembled or deactivated. If it is essential to disassemble or deactivate safety equipment for a repair operation, it must be assembled and put back into operation immediately afterward.



## 2.2 Signal words and symbols used in warnings




Warnings in the text are distinguished by color bars. The color scheme is based on the severity of the danger. Signal words indicate the severity of the danger.

**Signal words** Signal words and the hazard they describe:

Signal word	Meaning
<b>DANGER</b>	(with hazard symbol) If ignored, fatal or serious injury will result
<b>WARNING</b>	(with hazard symbol) If ignored, fatal or serious injury can result
<b>CAUTION</b>	(with hazard symbol) If ignored, moderate or minor injury can result
<b>CAUTION</b>	(with hazard symbol) If ignored, environmental damage can result
<b>NOTICE</b>	(without hazard symbol) If ignored, property damage can result

**Symbols** The following symbols indicate the type of danger to personnel:

Symbol	Type of danger
	General
	Electric shock

Symbol	Type of danger
	Puncture
	Crushing
	Environmental damage

**Examples** Examples of the layout of warnings in the text:

**DANGER**



**Type and source of danger!**

Consequences of non-compliance.

Measures for avoiding the danger.

↪ This is what a warning looks like for a hazard that will result in serious injury or even death if ignored.

**WARNING**



**Type and source of danger!**

Consequences of non-compliance.

Measures for avoiding the danger.

↪ This is what a warning looks like for a hazard that could result in serious or even fatal injury if ignored.

**CAUTION**



**Type and source of danger!**

Consequences of non-compliance.

Measures for avoiding the danger.

↪ This is what a warning looks like for a hazard that could result in moderate or minor injury if the warning is ignored.

## CAUTION



### **Type and source of danger!**

Consequences of non-compliance.

Measures for avoiding the danger.

- 
- ↪ This is what a warning looks like for a hazard that could result in environmental damage if ignored.

## NOTICE

### **Type and source of danger!**

Consequences of non-compliance.

Measures for avoiding the danger.

- 
- ↪ This is what a warning looks like for a hazard that could result in property damage if ignored.

## 3 Working basis


### 3.1 Order of the adjustments



#### Order

The adjustment positions for the machine are interdependent.

Always comply with the order of individual adjustment steps as specified.

It is absolutely essential that you follow all notices regarding prerequisites and subsequent settings that are marked with  in the margin.

#### NOTICE

##### Property damage may occur!

Risk of machine damage from incorrect order.

It is essential to follow the working order specified in these instructions.

### 3.2 Laying the cables

#### NOTICE

##### Property damage may occur!

Excess cables can impair the functioning of moving machine parts. This impairs the sewing function and can result in damage.

Lay excess cable as described above.

Ensure that all cables are laid in the machine such that the function of moving parts is not hampered.



To lay the cables:

1. Lay any excess cabling neatly in proper cable snakes.
2. Bind together the cable loops with cable ties.



#### Important

Tie loops wherever possible to fixed parts. The cables must be secured firmly.

3. Cut off any overlapping cable ties.

### 3.3 Disassembling the covers

**WARNING****Risk of injury from moving parts!**

Crushing possible.

Switch off the machine before removing covers.

**WARNING****Risk of injury from sharp parts!**

Puncture possible.

Switch off the machine before removing covers.

For many adjustments, you will have to disassemble the machine covers first in order to access the components.

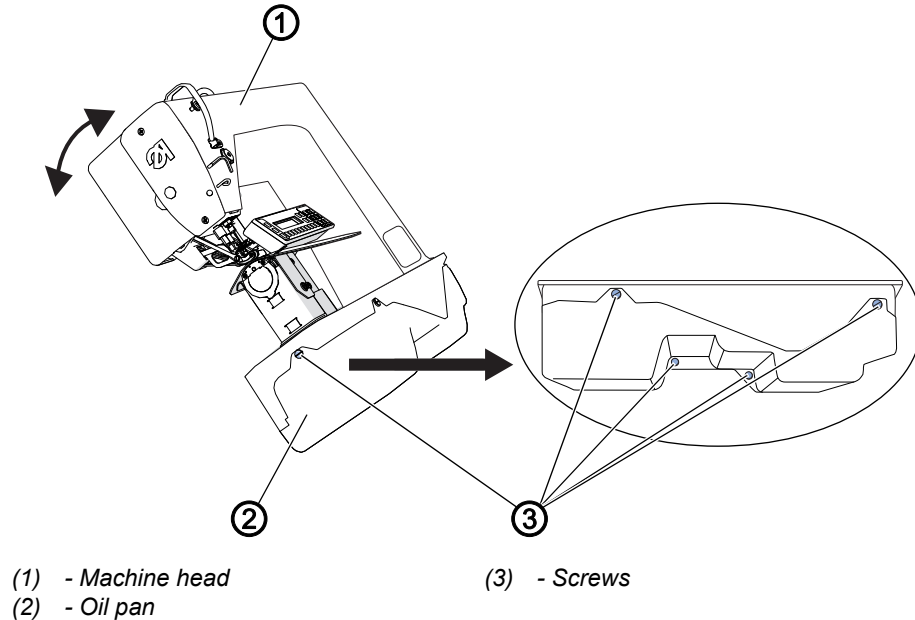
This chapter describes how to disassemble and then assemble the individual covers. The text for each type of adjustment work then specifies only the cover that needs to be disassembled at that particular time.



### 3.3.1 Tilting and re-erecting the machine head

To access the components on the underside of the machine, swivel up the machine head.

Fig. 1: Tilting and re-erecting the machine head



#### Tilting the machine head



To tilt the machine head:

1. Tilt the machine head (1) as far as it will go.
2. Loosen the screws (3).
3. Remove the oil pan (2) downwards.

#### Erecting the machine head

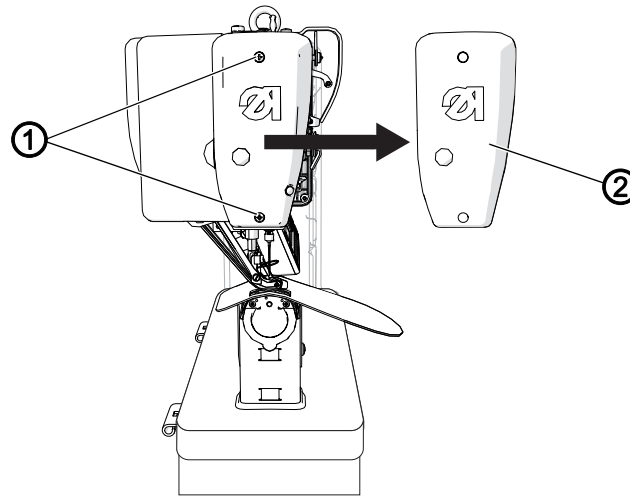


To erect the machine head:

1. Assemble the oil pan (2).
2. Tighten the screws (3).
3. Erect the machine head (1).

### 3.3.2 Disassembling and assembling the head cover

Fig. 2: Disassembling and assembling the head cover



(1) - Screws

(2) - Head cover

#### Disassembling the head cover



To disassemble the head cover:

1. Loosen the screws (1).
2. Disassemble the head cover (2).

#### Assembling the head cover

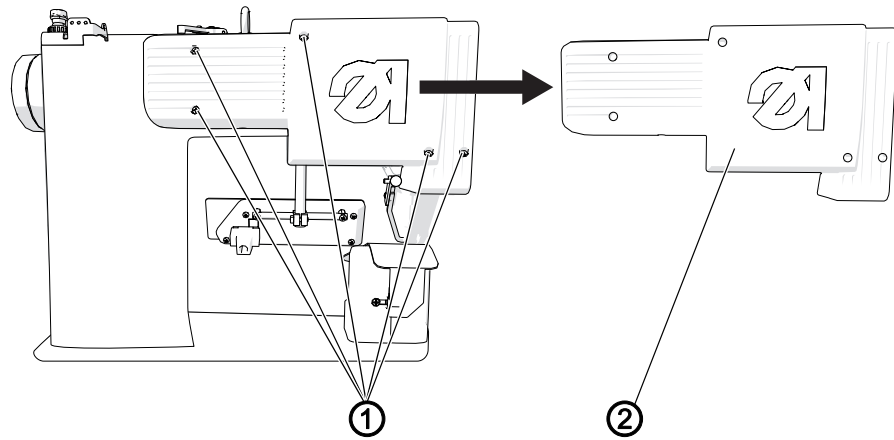


To assemble the head cover:

1. Assemble the head cover (2).
2. Tighten the screws (1).

### 3.3.3 Disassembling and assembling the rear machine arm cover

Fig. 3: Disassembling and assembling the rear machine arm cover



(1) - Screws

(2) - Rear machine arm cover

#### Disassembling the rear machine arm cover



To disassemble the rear machine arm cover:

1. Loosen the screws (1).
2. Disassemble the rear machine arm cover (2).

#### Assembling the rear machine arm cover

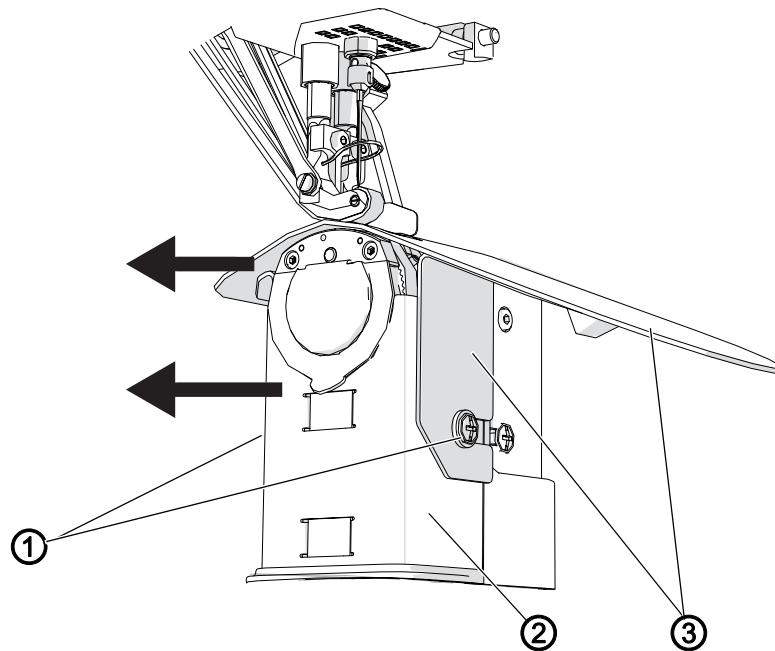


To place the rear machine arm cover:

1. Place the rear machine arm cover (2).
2. Tighten the screws (1).

### 3.3.4 Disassembling and assembling the sewing material support surface and column cover

Fig. 4: Disassembling and assembling the sewing material support surface and column cover



(1) - Screws  
(2) - Column cover

(3) - Sewing material support surface

#### Disassembling the sewing material support surface and column cover



To disassemble the sewing material support surface and column cover:

1. Loosen the screws (1).
2. Lift the sewing material support surface (3) slightly and remove it to the left.
3. Lift the column cover (2) slightly and remove it to the left.

#### Assembling the sewing material support surface and column cover

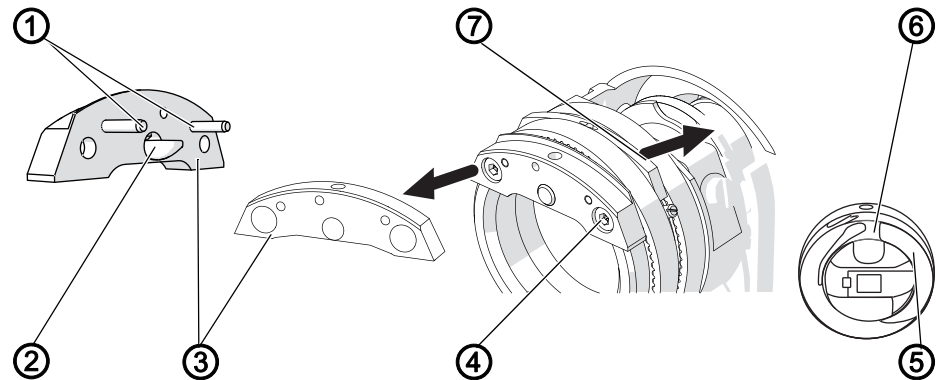


To assemble the sewing material support surface and column cover:

1. Place the column cover (2) from the top left.
2. Place the sewing material support surface (3) from the top left.
3. Tighten the screws (1).

### 3.3.5 Disassembling and assembling the throat plate

Fig. 5: Disassembling and assembling the throat plate




(1) - Pins  
 (2) - Middle section holder  
 (3) - Guide piece  
 (4) - Screws

(5) - Hook  
 (6) - Recess  
 (7) - Throat plate

#### Disassembling the throat plate




To disassemble the throat plate:

1. Disassemble the sewing material support surface and column cover ( p. 18).
2. Loosen the screws (4).
3. Remove the guide piece (3).
4. Remove the throat plate (7) upwards.

#### Assembling the throat plate

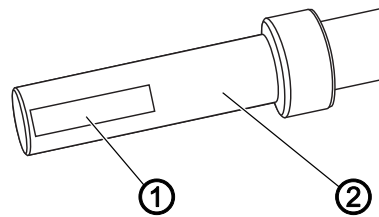


To assemble the throat plate:

1. Insert the throat plate (7) from above.
2. Insert the guide piece (3) such that the pins (1) engage in the throat plate (7) and the middle section holder (2) fits into the recess (6) for the hook (5).
3. Tighten the guide piece (3) using the screws (4).
4. Assemble the sewing material support surface and column cover ( p. 18).

### 3.4 Flats on shafts

Fig. 6: Flats on shafts



(1) - Flat

(2) - Shaft

Some shafts have flat surfaces at the points where the components are screwed on. This stabilizes the connection and makes adjusting easier. For all adjustments on the surface, the first screw in the direction of rotation is screwed onto the surface.



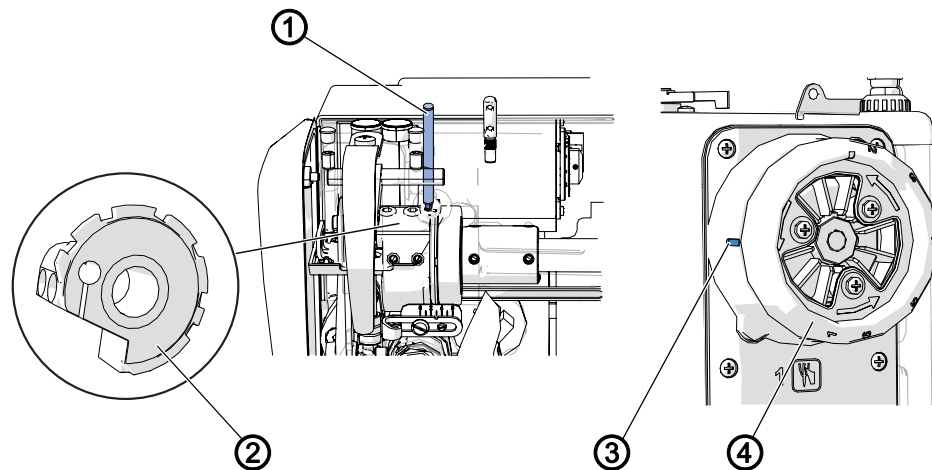
#### Important

Always ensure that the screw faces are completely flush with the surface.

### 3.5 Locking the machine in place

For some adjustments, the machine must be locked in place. To do this, the locking peg (1) from the accessories is inserted into a slot on the arm shaft crank (2), blocking the arm shaft.

Fig. 7: Locking the machine in place (1)



(1) - Locking peg

(2) - Arm shaft crank with arresting grooves

(3) - Marking

(4) - Handwheel

For orientation purposes, there are numbers on the handwheel (4). If you turn the handwheel with one of the numbers aligned to the marking (3), the appropriate groove of the arm shaft crank (2) will be underneath the opening for the locking peg (1).

There are 3 locking positions for the following settings:

- **Position 1**

- Looping stroke position
- Hook side clearance to the needle

- **Position 4**

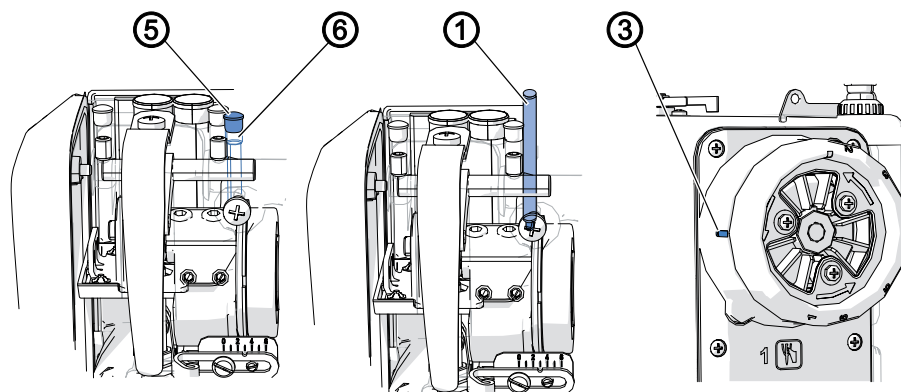
- Control cam for the thread trimmer

- **Position 6**

- Reference position for the control when the needle is in the lower dead center

Positions 2, 3, and 5 are not allocated.

Fig. 8: Locking the machine in place (2)



(1) - Locking peg

(3) - Marking

(5) - Plug

(6) - Locking opening

### Locking the machine in place



To lock the machine in place:

1. Remove the plug (5) from the locking opening (6).
2. Turn the handwheel until the number for the required locking position is next to the marking (3).
3. Insert the locking peg (1) through the locking opening (6) and into the groove of the arm shaft crank.



### Important

The numbers on the handwheel are used for rough orientation. If necessary, you may still have to turn the handwheel slightly in order to meet the groove exactly.

### Removing the lock



To remove the lock:

1. Pull out the locking peg (1).
2. Insert the plug (5) into the locking opening (6).





## 4 Position of the hook and needle

The following 3 settings must be coordinated with each other:

- Timing
- Hook side clearance to the needle
- Needle bar height

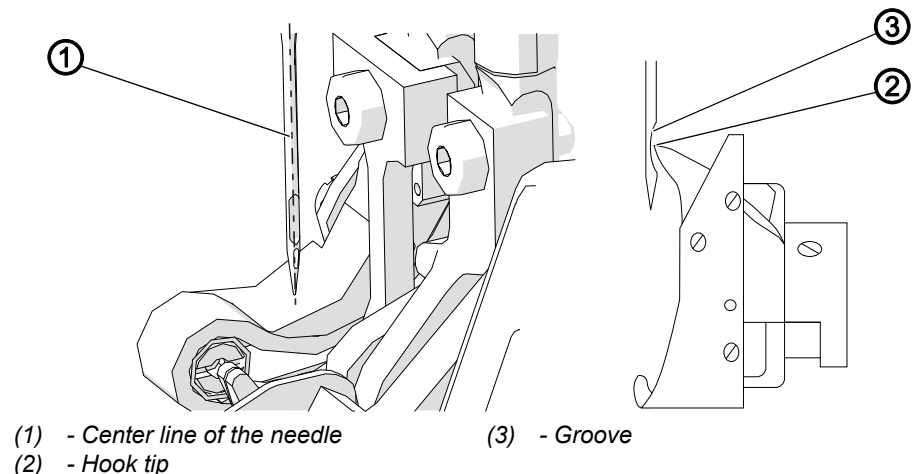


### Information

The **looping stroke position** is the position of the hook in which the hook tip points precisely at the center line of the needle.

The **looping stroke** is the path length from the bottom dead center of the needle bar up to the height where the hook is in the looping stroke position. The looping stroke is 1.8 mm.

Fig. 9: Position of the hook and needle



### Proper setting

When the machine is locked in the looping stroke position (*position 1*), the hook tip (2) should be precisely at the center line of the needle (1). The needle must be aligned such that the surface of the groove (3) is parallel to the sewing direction of the hook tip. From that height, the hook tip (2) should be in the lower third of the groove (3).



### Disturbance

- Damage to the hook
- Damage to the needle
- Skip stitches
- Thread breaking

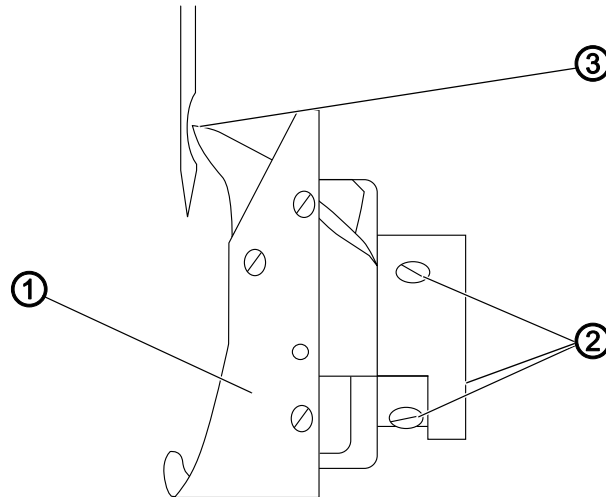
## 4.1 Adjusting looping stroke and hook side clearance



### Cover

- Disassemble the sewing material support surface and column cover (📖 p. 18)
- Disassemble the throat plate (📖 p. 19)

Fig. 10: Adjusting looping stroke and hook side clearance



- (1) - Hook  
(2) - Screws

(3) - Hook tip



To adjust the looping stroke and the hook side clearance:

1. Lock the machine in place at **position 1** (📖 p. 21).
2. Loosen the screws (2) of the hook.
3. Adjusting the looping stroke:  
Turn the hook (1) such that the hook tip (3) points exactly to the center line of the needle.
4. Adjusting the hook side clearance:  
Move the hook sideways such that the distance between the hook tip (3) and the groove of the needle is 0.05 – 0.1 mm.
5. Tighten the screws (2) of the hook without changing the looping stroke position or the hook side clearance.



### Order

After correcting the looping stroke position or the hook side clearance, check the needle bar height (📖 p. 25).

6. Remove the lock (📖 p. 21).

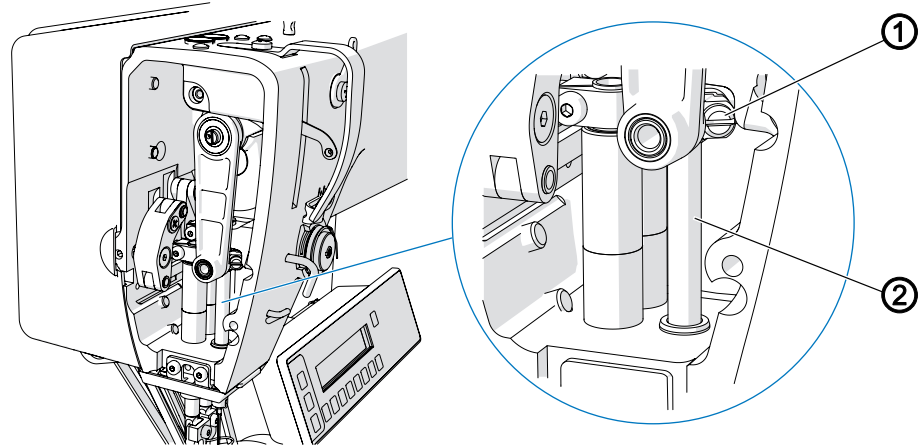
## 4.2 Adjusting the needle bar height



### Cover

- Disassemble the head cover (📖 p. 16)

Fig. 11: Adjusting the needle bar height



(1) - Screw

(2) - Needle bar



To adjust the needle bar height:

1. Lock the machine in place at **position 1** (📖 p. 21).
2. Loosen the screw (1).
3. Move the height of the needle bar (2) such that the hook tip is in the lower third of the groove for the needle.



### Important

When doing this, take care not to twist the needle bar to one side!

4. Tighten the screw (1).



### Order

After changing the needle bar height, check the looping stroke position and the hook side clearance as well (📖 p. 24).

### 4.3 Adjusting the thread passage on the middle section holder



#### Proper setting

The middle section holder (3) must only be inserted in the middle part of the hook deep enough that the thread can slip through the middle section holder (3) and the recess (5) for the hook (4) without problem.



#### Disturbance caused by an incorrect setting

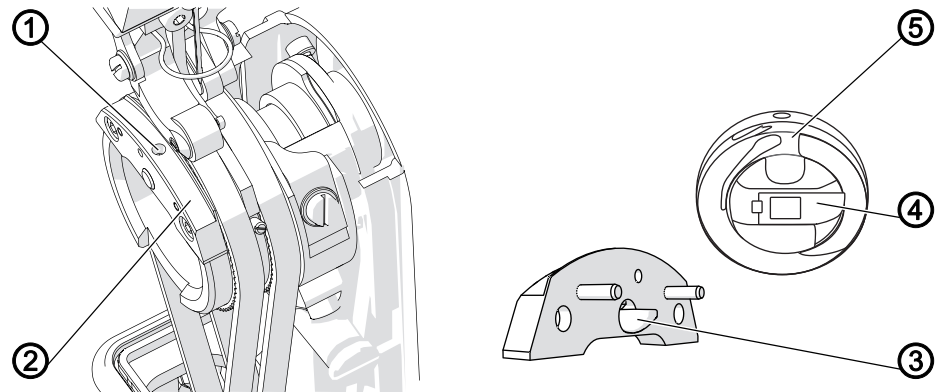
- Thread breaking
- Formation of loops



#### Cover

- Disassemble the sewing material support surface and column cover (p. 18)

Fig. 12: Adjusting the thread passage on the middle section holder



- (1) - Threaded pin  
 (2) - Guide piece  
 (3) - Middle section holder

- (4) - Hook  
 (5) - Recess



To adjust the thread passage on the middle section holder:

1. Turn the handwheel and check the passage of the thread.
2. Loosen the threaded pin (1).
3. Screw in or pull out the middle section holder (3).  
The distance from the hook must not become unnecessarily large.
4. Tighten the threaded pin (1).

#### 4.4 Adjusting the throat plate



##### Proper setting

The needle must enter the needle hole on the throat plate precisely in the center.



##### Disturbance

- Incorrect stitch formation



##### Cover


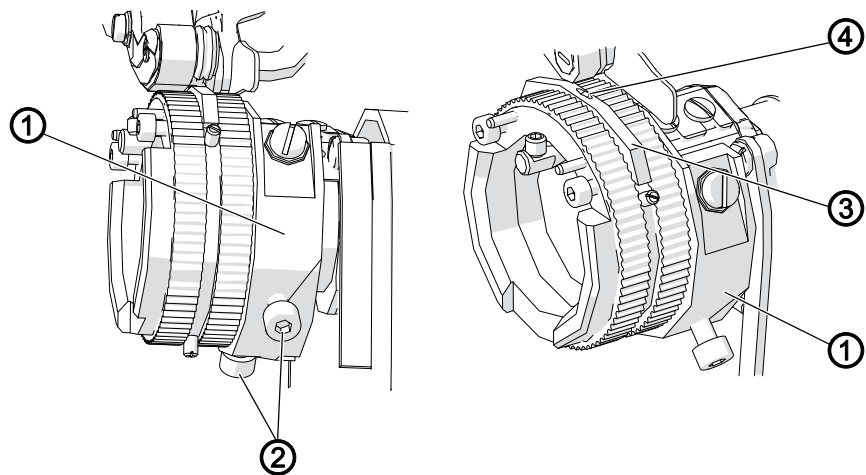
- Disassemble the sewing material support surface and column cover (  p. 18)

Fig. 13: Adjusting the throat plate




(1) - Column head  
(2) - Screws

(3) - Throat plate  
(4) - Needle hole



To adjust the throat plate:

1. Remove the lower conveyor belts in order to be able to turn the column head (1) (  p. 46).
2. Loosen the screws (2).
3. Use the hand wheel to turn the needle so far that insertion into the throat plate can be checked.
4. Turn the column head (1) and move it sideways such that the needle pierces exactly in the center of the needle hole (4) on the throat plate (3).
5. Tighten the screws (2) without changing the position of the column head (1).

## 5 Adjusting the thread trimmer

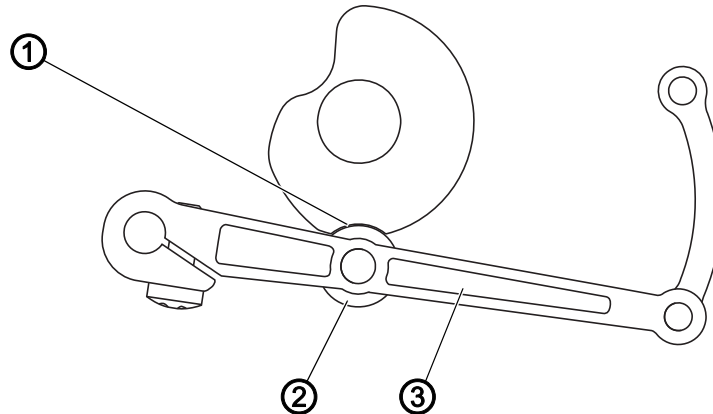
To ensure that the thread trimmer functions correctly, you need to adjust the control cam as well as the thread-pulling knife and the counter blade.

### 5.1 Adjusting the control cam

The control cam determines the path and timing of the cutter movement and adjusts the cutter movement to the needle movement. To ensure a correct setting, the position of the control cam and the distance between the control cam and the roller must be set.

#### 5.1.1 Adjusting the control cam position

Fig. 14: Adjusting the control cam position (1)



(1) - Small recess  
(2) - Roller

(3) - Thread trimmer lever



#### Proper setting

Lock the machine in place at **position 4** (📖 p. 21).

👉 When you push the thread trimmer lever (3) upwards, the roller (2) latches into place exactly in the small recess (1) of the control cam.



#### Disturbance

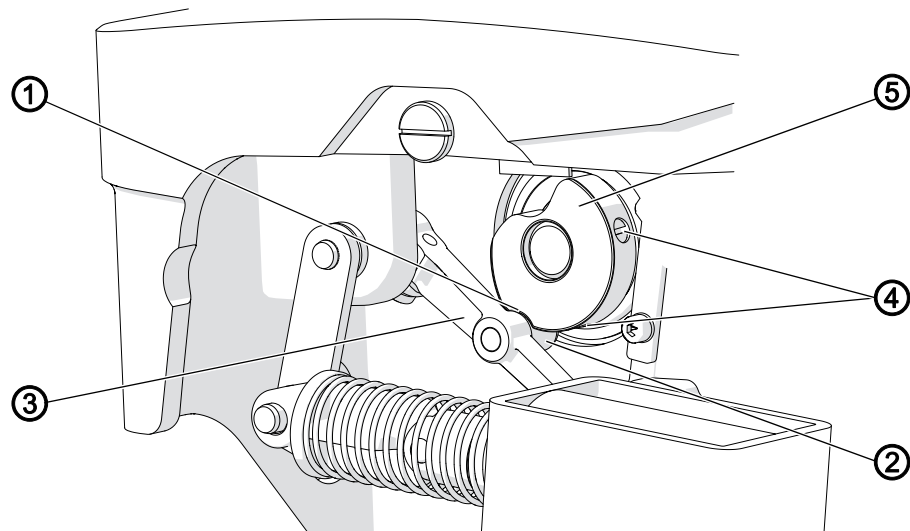
- Damage to the needle
- Threads are not cut



#### Cover

- Tilt the machine head (📖 p. 15)

Fig. 15: Adjusting the control cam position (2)





(1) - Small recess  
 (2) - Roller  
 (3) - Thread trimmer lever

(4) - Threaded pins  
 (5) - Control cam



To adjust the position of the control cam:

1. Lock the machine in place at **position 4** ( p. 21).
2. Loosen the threaded pins (4).
3. Push the thread trimmer lever (3) upwards and turn the control cam (5) such that the roller (2) latches into place exactly in the small recess (1).
4. Tighten the threaded pins (4) without changing the position of the control cam.
5. Remove the lock ( p. 21).

### 5.1.2 Adjusting the distance between control cam and roller



#### Proper setting

When the thread trimmer is at rest, the distance between the roller and the control cam at its maximum diameter is 0.2 mm.



#### Important

Do not measure the distance at one of the recesses! To check and set the control cam, turn it so that the recesses do not point towards the roller.



#### Disturbance

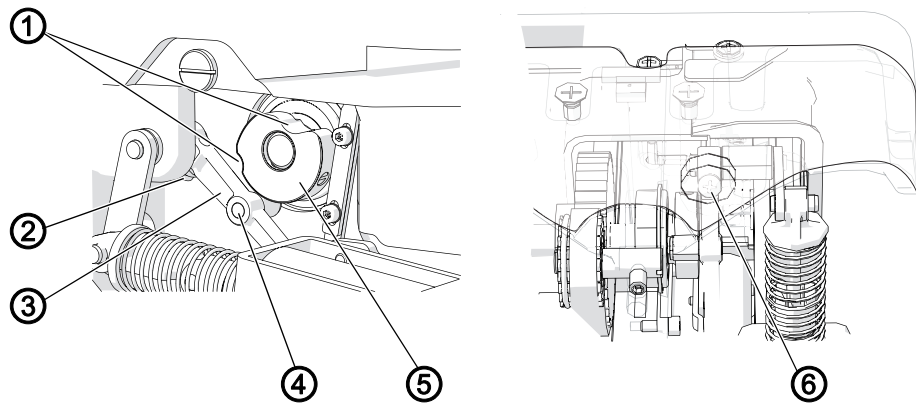
- Thread-pulling knife jammed with counter blade



#### Cover

- Tilt the machine head ( p. 15)

Fig. 16: Adjusting the distance between control cam and roller



- |                            |                     |
|----------------------------|---------------------|
| (1) - Recesses             | (4) - Roller        |
| (2) - Screw                | (5) - Control cam   |
| (3) - Thread trimmer lever | (6) - Screw opening |



To adjust the distance between the control cam and the roller:

1. Turn the handwheel such that the recesses (1) on the control cam (5) do not point towards the roller (4).
2. Tighten the screw (2) of the thread trimmer level (3) through the screw opening (6) in the housing.
3. Push the thread trimmer lever (3) so far up or down that the distance between the roller (4) and the control cam (5) at its maximum diameter is 0.2 mm.



**Important**

The armature of the thread trimmer magnet must be completely extended!

4. Tighten the screw (2) of the thread trimmer level (3) through the screw opening (6) in the housing without changing the position of the lever.



## 5.2 Replacing and adjusting the thread-pulling knife



### Proper setting

The cutouts in the thread-pulling knife are pushed onto the screws as far as they can go.



### Disturbance

- Threads are not cut
- Threads are cut too long



### Cover




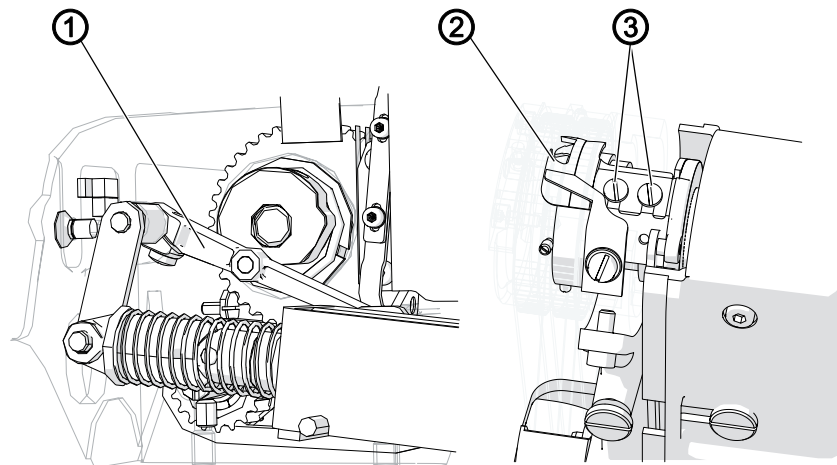
- Tilt the machine head ( p. 15)
- Disassemble the sewing material support surface and column cover ( p. 18)
- Disassemble the throat plate ( p. 19)

Fig. 17: Replacing and adjusting the thread-pulling knife



(1) - Thread trimmer lever

(2) - Thread-pulling knife

(3) - Screws



To change and adjust the thread-pulling knife:

1. Push the thread trimmer lever (1) upwards and turn the handwheel until the thread-pulling knife (2) swivels forward and the screws (3) are accessible.
2. Loosen the screws (3).
3. Remove the old thread-pulling knife backwards whilst releasing the thread trimmer lever (1) downwards.
4. Insert the new thread-pulling knife.
5. Push the thread-pulling knife (2) forward onto the screws (3) as far as it will go.
6. Tighten the screws (3).

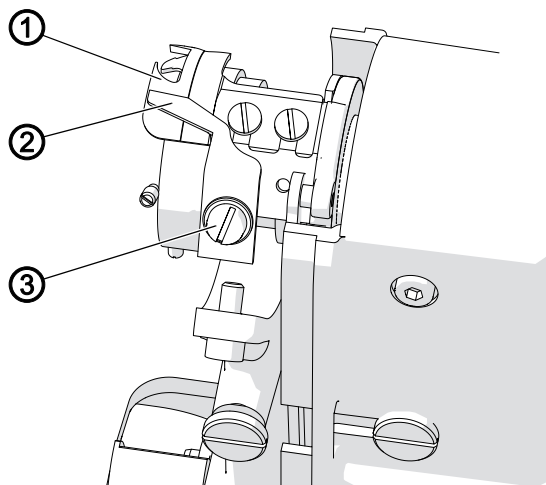
### 5.3 Changing the counter blade



#### Cover

- Disassemble the sewing material support surface and column cover (📖 p. 18)

Fig. 18: Changing the counter blade



- (1) - Thread-pulling knife  
(2) - Counter blade

- (3) - Screw



To replace the counter blade:

1. Loosen the screw (3).
2. Remove the old counter blade.
3. Insert the new counter blade.
4. Tighten the screw (3).

### 5.4 Adjusting the counter blade and cutting pressure

The shape of the thread-pulling knife and the counter blade creates a scissor effect. The threads must be cut using as little pressure as possible. Do not set the pressure higher than necessary. The higher the pressure, the more the knife wears.



#### Proper setting

Any 2 threads with the greatest strength used for sewing can be neatly cut simultaneously.



#### Disturbance

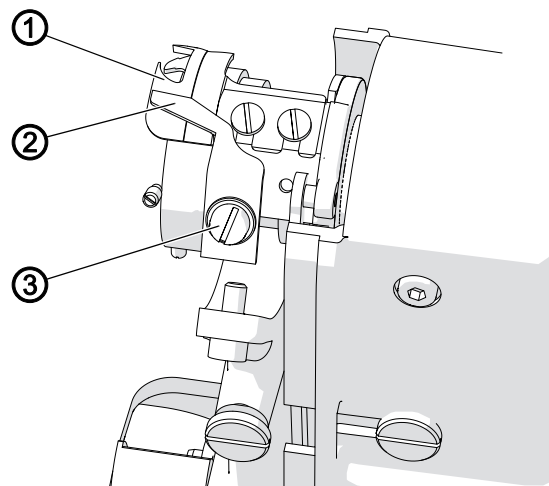
- Increased knife wear
- Threads are not cut
- Threads are cut too long



#### Cover

- Tilt the machine head (📖 p. 15)
- Disassemble the sewing material support surface and column cover (📖 p. 18)
- Disassemble the throat plate (📖 p. 19)

Fig. 19: Adjusting the counter blade and cutting pressure



(1) - Thread-pulling knife  
(2) - Counter blade

(3) - Screw



To adjust the counter blade and cutting pressure:

1. Push the thread trimmer lever upwards and turn the handwheel until the thread-pulling knife (1) swivels forward.
2. Loosen the screw (3).
3. Push the counter blade (2) upwards or downwards such that the cutting edges of the thread-pulling knife (1) and the counter blade (2) touch without snagging.
4. Tighten the screw (3).
5. Perform a cutting test and make adjustments as necessary.

## 5.5 Adjusting the path of the thread-pulling knife



### Proper setting

If the thread-pulling knife is not swung out, the tips of the thread-pulling knife and the counter blade are exactly flush on top of each other.



### Disturbance

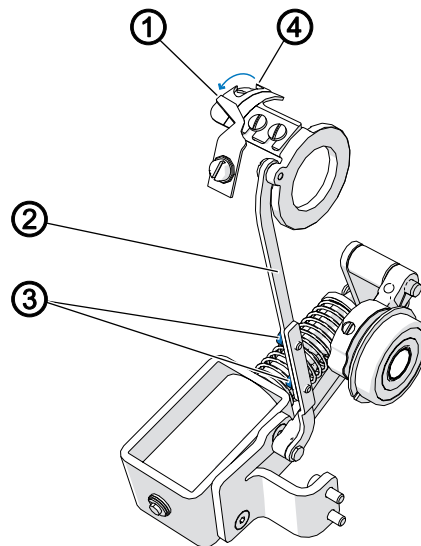
- Threads are not cut
- Threads are cut too long



### Cover

- Tilt the machine head (📖 p. 15)
- Disassemble the sewing material support surface and column cover (📖 p. 18)
- Disassemble the throat plate (📖 p. 19)

Fig. 20: Adjusting the path of the thread-pulling knife



- (1) - Tip of the counter blade edge  
 (2) - Blade lever  
 (3) - Screws

- (4) - Tip of the thread-pulling knife blade



To adjust the path of the thread-pulling knife:

1. Loosen the screws (3).
2. Push the blade lever (2) upwards or downwards such that the tip of the thread-pulling knife edge (4) is exactly flush with the tip of the counter blade edge (1).
3. Tighten the screws (3).
4. Perform a cutting test and make adjustments as necessary.



If the threads are **cut too long**:

1. Push the thread-pulling knife further back.



If the threads are **not cut**:

1. Push the thread-pulling knife further forward.

## 6 Adjusting the presser foot

In its delivery state, the distance between the throat plate and the presser foot is exactly 0.6 mm.



### Proper setting

The correct height of the presser foot depends on the thickness of the sewing material:

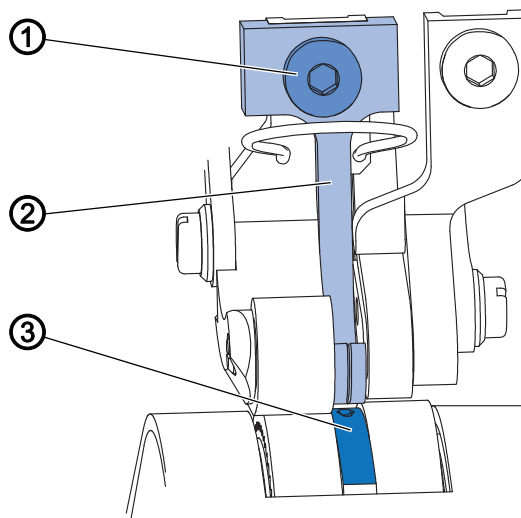
- Thick sewing material: Set the presser foot higher
- Thin sewing material: Set the presser foot lower



### Disturbances caused by an incorrect setting

- Presser foot too low for thick sewing material:
  - Incorrect curve support
  - Fullness incorporated incorrectly
  - Ruffling on the seam
  - Unsuitable stitch length
- Presser foot too high for thin sewing material:
  - Ruffling on the seam

Fig. 21: Adjusting the presser foot



(1) - Screw

(2) - Presser foot

(3) - Throat plate



To adjust the presser foot:

1. Remove the needle.
2. Loosen the screw (1).
3. Push the presser foot (2) up or down until the height matches the thickness of the sewing material.
4. Tighten the screw (1).
5. Insert the needle again.

## 7 Toothed belt

### 7.1 Adjusting the toothed belt between upper and lower shaft



#### Proper setting

At the front strand, the tension of the toothed belt is 60 – 80 Hz.



#### Cover


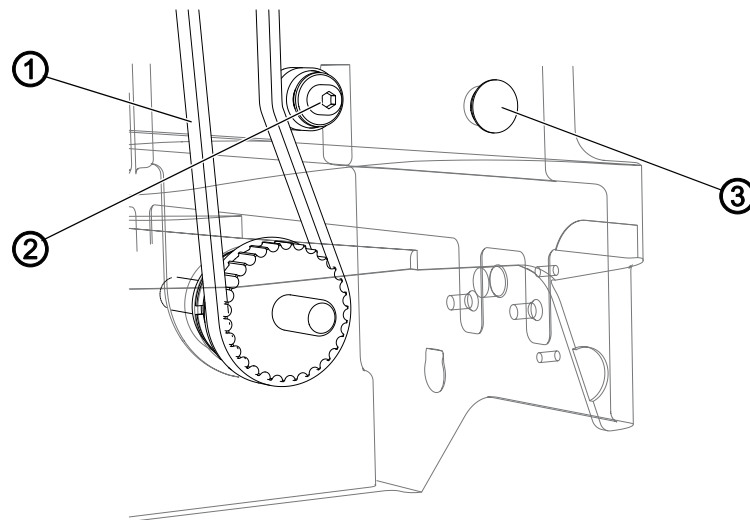
- Tilt the machine head ( p. 15)

Fig. 22: Adjusting the toothed belt between upper and lower shaft

#### Side view



(1) - Toothed belt (front strand)  
(2) - Screw

(3) - Plug




To adjust the toothed belt between the upper and lower shaft:

1. Remove the plug (3).
2. Insert the wrench from the right through the housing opening into the screw (2).
3. Loosen the screw (2).
4. Change the tension using the tension pulley:
  - **increased tension:** Place the pulley nearer to the toothed belt
  - **decreased tension:** Place the pulley further from the toothed belt
5. Tighten the screw (2).



#### Order

Make the following adjustment after completely re-assembling the toothed belt between the upper and lower shaft:

- Position of the hook ( p. 24)

## 7.2 Adjusting the toothed belt for the hook drive



### Proper setting

At the front strand, the tension of the toothed belt is 65 Hz.  
The toothed belt is centered on the upper toothed belt wheel and on the large toothed belt wheel.  
The toothed belt has a clearance of 1 mm from the retaining rings on the lower toothed belt wheels.



### Cover



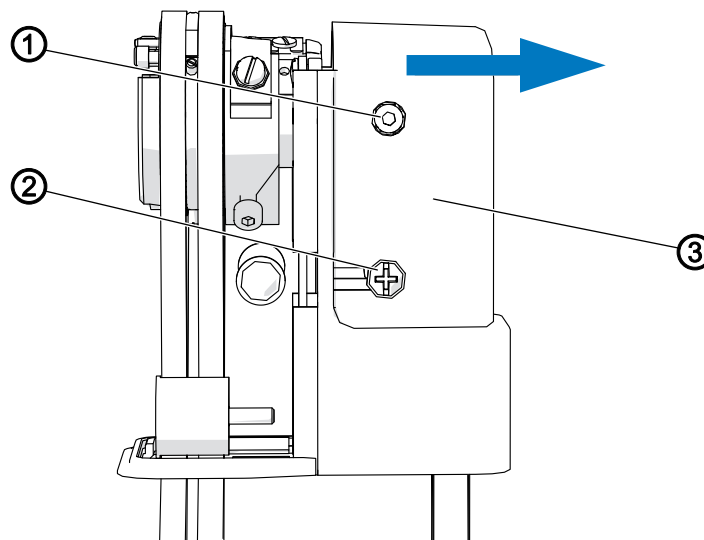
- Tilt the machine head ( p. 15)
- Disassemble the sewing material support surface and column cover ( p. 18)

Fig. 23: Adjusting the toothed belt for the hook drive (1)



(1) - Screw  
(2) - Screw

(3) - Cover



To adjust the toothed belt for the hook drive:

1. Loosen the screws (2) on the front and rear of the cover (3) of the hook toothed belt.

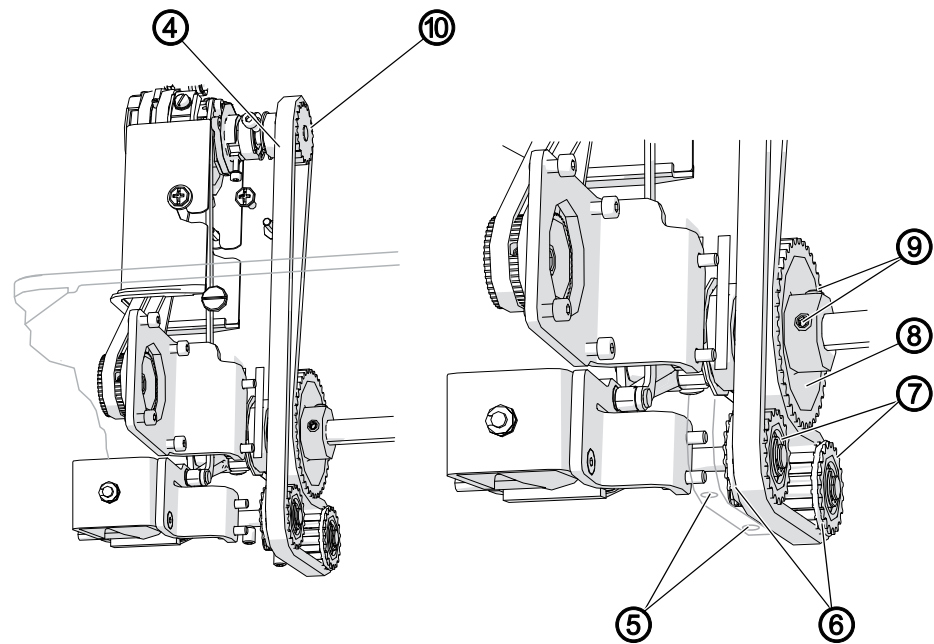


### Important

Do NOT loosen the screw (1)!  
If the screw (1) has been unscrewed, re-adjust the hook ( p. 24).

2. Lift the cover (3) slightly and remove it to the right.

Fig. 24: Adjusting the toothed belt for the hook drive (2)



- (4) - Toothed belt
- (5) - Screw openings
- (6) - Retaining rings
- (7) - Lower toothed belt wheels

- (8) - Large toothed belt wheel
- (9) - Threaded pins
- (10) - Toothed belt wheel



3. Loosen the axis fastening of the lower toothed belt wheels (7) through the screw openings (5).
4. Loosen the threaded pins (9) for the large toothed belt wheel (8).
5. Align the toothed belt wheels:
  - move the lower toothed belt wheels (7) together with their axles
  - move the large toothed belt wheel (8) on the shaft

Move the 3 toothed belt wheels such that:

  - the toothed belt is centered on the upper toothed belt wheel (10) and centered on the large toothed belt wheel (8)
  - the toothed belt on the lower toothed belt wheels (7) has a clearance of 1 mm from the retaining rings (6)
6. Tighten the threaded pins (9) for the large toothed belt wheel (8).
7. Tighten the axis fastening of the lower toothed belt wheels (7) through the screw openings (5).
8. Place the cover from the top right.
9. Tighten the screws on the front and rear of the cover.



**Order**

Check the following setting after completely re-assembling the toothed belt or loosening the large toothed belt pulley:

- Position of the hook (📖 p. 24)



## 8 Upper conveyor belts (old system)

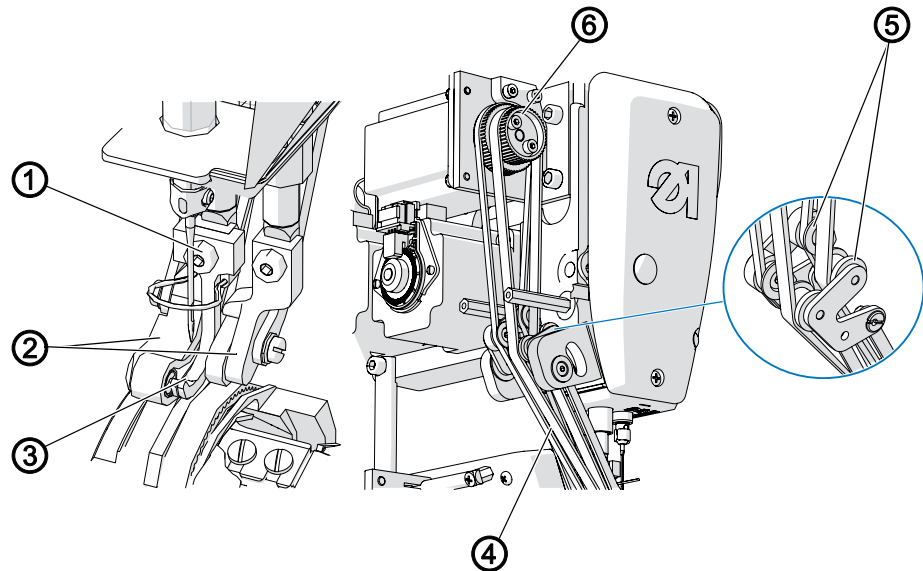
### 8.1 Replacing the top conveyor belts



#### Cover

- Disassemble the rear machine arm cover (📖 p. 17)

Fig. 25: Replacing the top conveyor belts



- |                    |                      |
|--------------------|----------------------|
| (1) - Screw        | (4) - Conveyor belts |
| (2) - Sewing feet  | (5) - Guide          |
| (3) - Presser foot | (6) - Gear wheels    |

#### Disassembling the top conveyor belts



To disassemble the top conveyor belts:

1. Remove the needle.
2. Loosen the screw (1).
3. Remove the presser foot (3).
4. Push the right sewing foot upwards.
5. Remove the left conveyor belt from the sewing foot.
6. Remove the left conveyor belt from the gear wheel (6) and from the guide (5).
7. Push the left sewing foot upwards and the right sewing foot downwards.
8. Remove the right conveyor belt from the sewing foot.
9. Remove the right conveyor belt from the gear wheel (6) and from the guide (5).

### Inserting the top conveyor belts



To insert the top conveyor belts:

1. Push the right sewing foot downwards and the left sewing foot upwards.
2. Place the right conveyor belt in the right sewing foot.
3. Guide the right conveyor belt through the guide (5).
4. Place the right conveyor belt on the larger of the two gear wheels (6).
5. Turn the conveyor belt gear wheel (6) slowly so that the conveyor belt aligns itself.
6. Push the right sewing foot upwards and the left sewing foot downwards.
7. Place the left conveyor belt in the left sewing foot.
8. Insert the presser foot (3) and tighten it using the screw (1).
9. Guide the left conveyor belt through the guide (5).
10. Place the left conveyor belt on the smaller of the two gear wheels (6).
11. Turn the gear wheel (6) slowly so that the belt aligns itself.



#### Order

After replacing the top conveyor belts, adjust the presser foot ( p. 35).

## 8.2 Adjusting the top conveyor belts



#### Proper setting



The tension in the conveyor belts should be set as low as possible without allowing the conveyor belts to sag.

The jump protection must not impede the course of the right conveyor belt. The correct distance between the jump protection and the right conveyor belt is 0.2 – 0.3 mm.



#### Information

Test possibilities for the stepper motors of the conveyor belts can be found in the software:

- OP3000 ( p. 79)
- OP7000 ( p. 108)



#### Disturbance

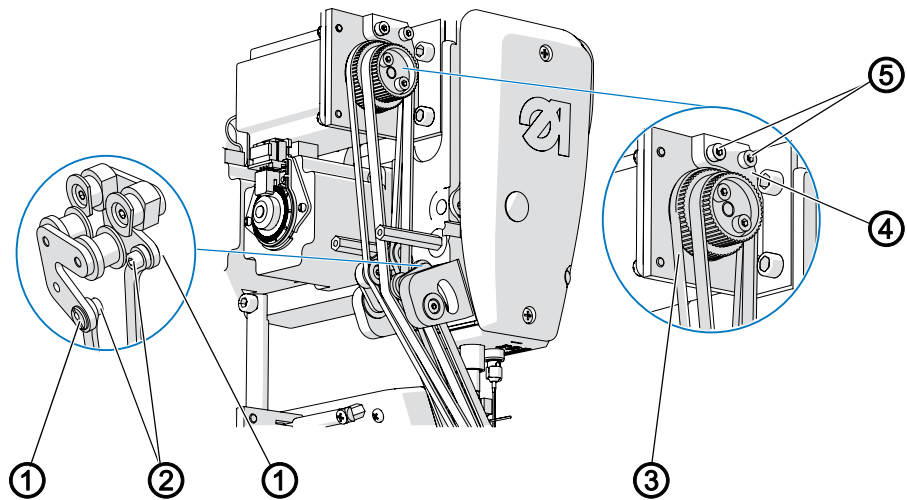
- Irregular stitch length due to excessively low tension
- Transport disruptions and ruffling due to excessively high tension
- Increased wear of belts and feet
- Incomplete lowering of feet



#### Cover

- Disassemble the rear machine arm cover ( p. 17)

Fig. 26: Adjusting the top conveyor belts



- (1) - Eccentric  
 (2) - Screws  
 (3) - Top right conveyor belt

- (4) - Jump protection  
 (5) - Screws

### Adjusting the tension



To adjust the tension:

1. Loosen the screws (2).
2. Turn the appropriate eccentric (1) with a flat-head screw driver in order to change the tension.
3. Tighten the screws (2).
4. Make the adjustment for the other conveyor belt as well.

### Adjusting the distance from the jump protection



To adjust the distance from the jump protection:

1. Loosen the screws (5).
2. Push the jump protection (4) upwards or downwards until there is a distance of 0.2 – 0.3 mm from the top right conveyor belt (3).
3. Tighten the screws (5).

## 9 Upper conveyor belts (new system)

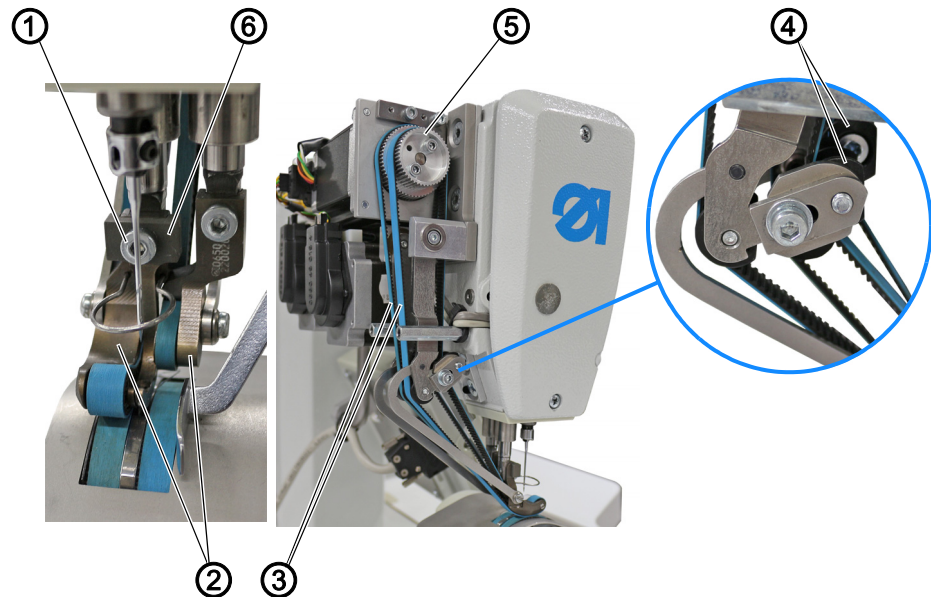
### 9.1 Replacing the top conveyor belts



#### Cover

- Disassemble the rear cover (📖 p. 17)

Fig. 27: Replacing the top conveyor belts



- |                      |                    |
|----------------------|--------------------|
| (1) - Screw          | (4) - Guides       |
| (2) - Sewing feet    | (5) - Gear wheels  |
| (3) - Conveyor belts | (6) - Presser foot |



To disassemble the top conveyor belts:

1. Remove the needle.
2. Loosen the screw (1).
3. Disassemble the presser foot (6).
4. Push the right sewing foot upwards.
5. Remove the left conveyor belt from the sewing foot.
6. Remove the left conveyor belt from the gear wheel (5) and from the guide (4).
7. Push the left sewing foot upwards and the right sewing foot downwards.
8. Remove the right conveyor belt from the sewing foot.
9. Remove the right conveyor belt from the gear wheel (5) and from the guide (4).

### Inserting the top conveyor belts




To insert the top conveyor belts:

1. Push the right sewing foot downwards and the left sewing foot upwards.
2. Place the right conveyor belt in the right sewing foot.
3. Guide the right conveyor belt through the guide (4).
4. Place the right conveyor belt on the larger of the two gear wheels (5).
5. Turn the gear wheel (5) slowly so that the conveyor belt aligns itself.
6. Push the right sewing foot upwards and the left walking foot downwards.
7. Place the left conveyor belt in the left sewing foot.
8. Insert the presser foot (6).
9. Tighten the screw (1).
10. Guide the left conveyor belt through the guide (4).
11. Place the left conveyor belt on the smaller of the gear wheels (5).
12. Turn the gear wheel (5) slowly so that the conveyor belt aligns itself.



#### Order

- After replacing the top conveyor belts, adjust the presser foot ( p. 35).

## 9.2 Adjusting the top conveyor belts



#### Proper setting



The tension in the conveyor belts should be set as low as possible without allowing the conveyor belts to sag.

The jump protection must not impede the course of the right conveyor belt. The correct distance between the jump protection and the right conveyor belt is 0.2- 0.3 mm.



#### Information

Test possibilities for the stepper motors of the conveyor belts can be found in the software:

- OP3000 ( p. 79)
- OP7000 ( p. 108)



#### Disturbance

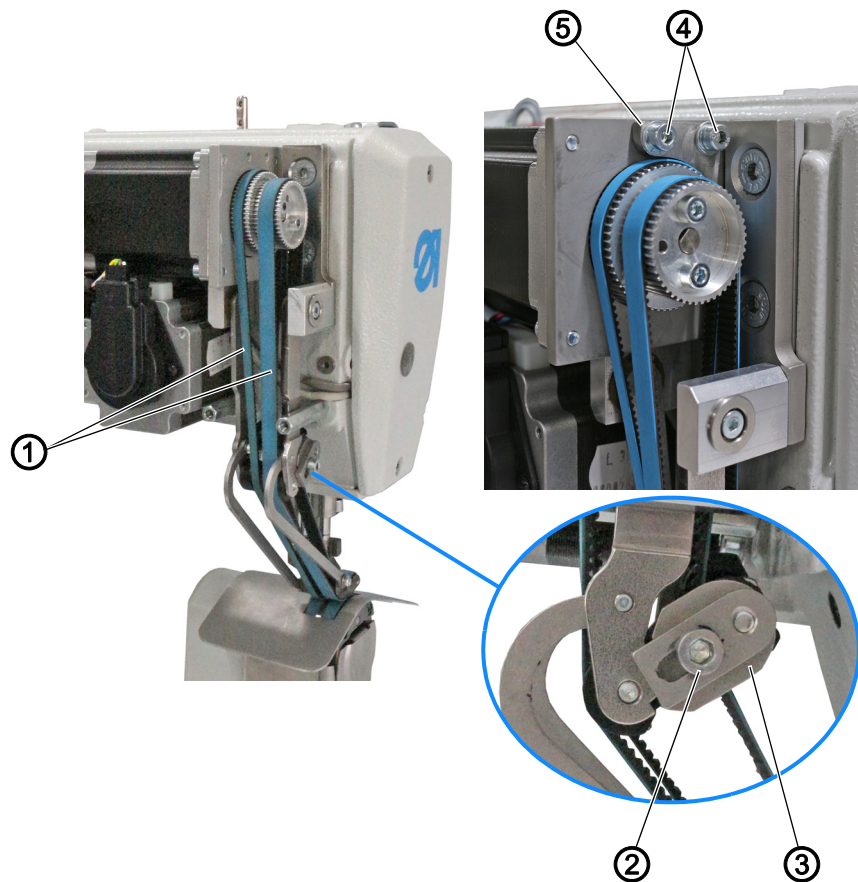
- Irregular stitch length due to excessively low tension
- Transport disruptions and ruffling due to excessively high tension
- Increased wear of belts and feet
- Incomplete lowering of feet



**Cover**

- Disassemble the rear machine arm cover (📖 p. 17)

Fig. 28: Adjusting the top conveyor belts



- (1) - Conveyor belts
- (2) - Screw
- (3) - Guide piece

- (4) - Screws
- (5) - Jump protection

**Adjusting the tension**



To adjust the tension:

1. Loosen the screw (2).
2. To tighten the conveyor belts (1), move the guide piece (3).
  - To increase the tension: Slide the guide piece (3) to the left
  - To reduce the tension: Slide the guide piece (3) to the right
3. Tighten the screw (2).

### Adjusting the distance from the jump protection



To adjust the distance from the jump protection:

1. Loosen the screws (4).
2. Push the jump protection (5) upwards or downwards until there is a distance of 0.2 - 0.3 mm from the top right conveyor belt (1).
3. Tighten the screws (4).

## 10 Bottom conveyor belts

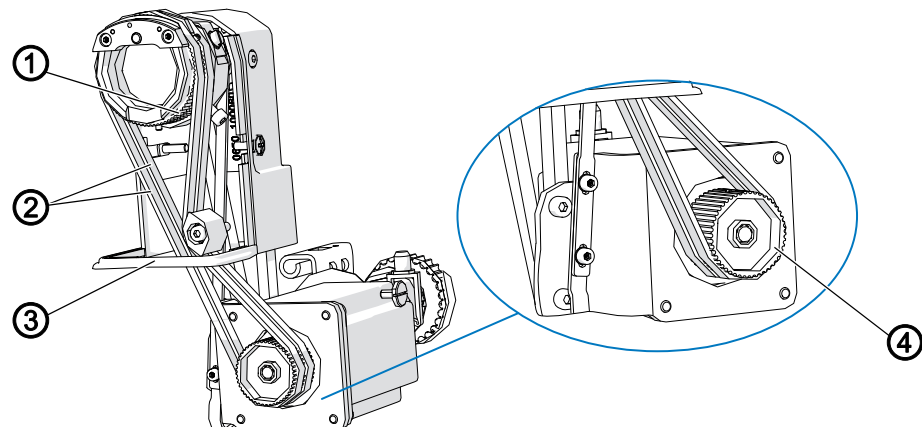
### 10.1 Replacing the bottom conveyor belts



#### Cover

- Tilt the machine head (📖 p. 15)
- Disassemble the sewing material support surface and column cover (📖 p. 18)
- Disassemble the throat plate (📖 p. 19)

Fig. 29: Replacing the bottom conveyor belts



- |                             |                         |
|-----------------------------|-------------------------|
| (1) - Gear rims             | (3) - Base plate cutout |
| (2) - Bottom conveyor belts | (4) - Bottom gear wheel |

#### Disassembling the bottom conveyor belts



To disassemble the bottom conveyor belts:

1. Use the handwheel to position the needle in the top dead center.
2. Remove both conveyor belts (2) from the bottom gear wheel (4).
3. Pull the conveyor belts (2) upwards through the base plate cutout (3).
4. Remove both conveyor belts from the gear rims on the throat plate (1) one after the other.

#### Inserting the bottom conveyor belts



To insert the bottom conveyor belts:

1. Pull the right conveyor belt over the right gear rim (1).
2. Feed the conveyor belt downwards through the base plate cutout (3).
3. Pull the conveyor belt over the lower gear wheel (4).
4. Insert the left conveyor belt accordingly.



## 10.2 Adjusting the bottom conveyor belts



### Proper setting

The tension in the conveyor belts should be set as low as possible without allowing the conveyor belts to sag. The conveyor belts must be able to nestle up against each other when light pressure is exerted.





### Disturbance

- Irregular stitch length due to excessively low tension
- Transport disruptions and ruffling due to excessively high tension
- Increased wear of belts



### Information

Test possibilities for the stepper motors of the conveyor belts can be found in the software:

- OP3000 ( p. 79)
- OP7000 ( p. 108)



### Cover



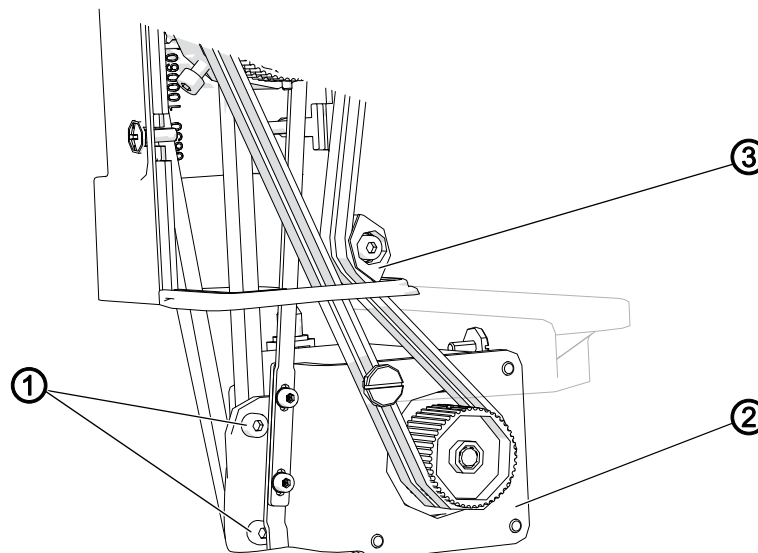
- Tilt the machine head ( p. 15)
- Disassemble the sewing material support surface and column cover ( p. 18)

Fig. 30: Adjusting the bottom conveyor belts



- (1) - Screws  
(2) - Bracket

(3) - Sliding block



To adjust the bottom conveyor belts:

1. Loosen the two screws (1).
2. Move the bracket (2) together with the gear wheel and conveyor belts:
  - Move downwards = greater tension
  - Move upwards = lower tension

3. Tighten the screws (1).
- If the tension is not enough:
4. Loosen the screw on the sliding block (3).
  5. Turn the sliding block (3) counterclockwise.
  6. Tighten the screw on the sliding block (3).  
Make sure that the screw is not too tight.

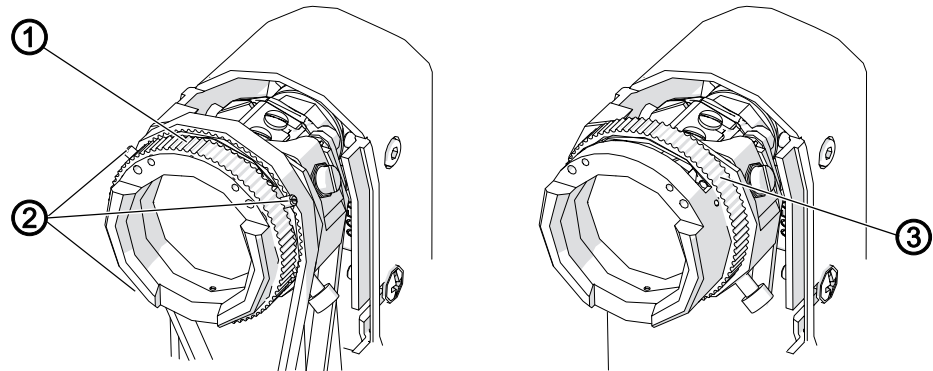
### 10.3 Replacing the gear rims



#### Cover

- Tilt the machine head (📖 p. 15)
- Disassemble the sewing material support surface and column cover (📖 p. 18)
- Disassemble the throat plate (📖 p. 19)

Fig. 31: Replacing the gear rims



- (1) - Front gear rim  
(2) - Screws

- (3) - Rear gear rim

#### Disassembling the gear rims



To disassemble the gear rims:

1. Remove the bottom conveyor belts (📖 p. 46).
2. Remove the front gear rim (1) to the left.
3. Loosen the screws (2).
4. Remove the rear gear rim (3) to the left.

#### Assembling the gear rims




To assemble the gear rims:

1. Slip on the rear gear rim (3) from the left.
2. Tighten the screws (2).
3. Slip on the front gear rim (1) from the left.
4. Insert the bottom conveyor belts (📖 p. 46).

## 11 Checking the sewing foot lifting gear



### Proper setting

1. Switch off the machine.
  2. Move the sewing feet back and forth by hand.
-  The sewing feet must be able to move back and forth slightly.

You can change the following settings for the sewing feet via software:

- Sewing foot lift
- Sewing foot calibration

### Checking for mechanical problems



To check the sewing foot lifting gear for mechanical problems:

1. Disassemble the lifting gear as described below.
2. Check components for defects.
3. Assemble the lifting gear as described below.





### Disturbance

- Incorrect curve support
- Sewing foot stuck



### Order

After checking for mechanical problems, recalibrate the sewing feet via software.

- OP3000 ( p. 80)
- OP7000 ( p. 104)



### Cover



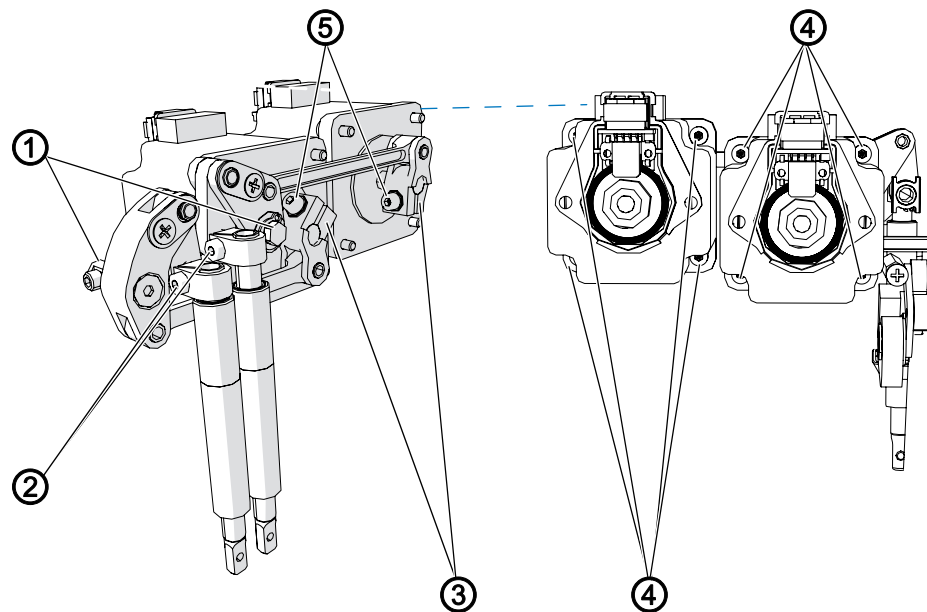
- Disassemble the rear machine arm cover ( p. 17)
- Disassemble the head cover ( p. 16)

Fig. 32: Checking the sewing foot lifting gear



- (1) - Bearing points
- (2) - Screws
- (3) - Clamping block

- (4) - Screws
- (5) - Screws

### Disassembling the sewing foot lifting gear



To disassemble the lifting gear:

1. Push the right sewing foot upwards to allow free access.
2. Loosen the screws (5).  
This can be accessed through the machine head.
3. Loosen the screws (4) of the stepper motors from the rear.
4. Remove the stepper motors backwards.
5. Loosen the screws (2).
6. Remove the electric thread tension in order to gain access to the bearing point in the right lifting gear (📖 p. 52).  
You do not need to remove the thread tension cables from the plug to do this.



#### Important

Make sure not to damage the cables when pulling out the thread tension!

7. Loosen the bearing points (1).  
These can be accessed through the machine head for the left lifting gear. For the right lifting gear, these can be accessed through the opening of the removed thread tension.
8. Remove lifting gear.




#### Proper setting

All pivots and bearing points must be able to move slightly and must not have any play.

### Assembling the lifting gear



To assemble the lifting gear:

1. Place the lifting gear.
2. Tighten the bearing points (1).  
These can be accessed through the machine head for the left lifting gear. For the right lifting gear, these can be accessed through the opening of the removed thread tension.
3. Insert the electric thread tension ( p. 52).



#### Important

Make sure you do not damage the cables and you properly lay cables that are too long when inserting the thread tension!

4. Tighten the screws (2).



#### Important

The upper edge of the clamping block must lock flush with the upper end of the sewing foot rod!

5. Place the stepper motors.
6. Place the clamping blocks (3) on the stepper motor shaft.
7. Screw on the stepper motors from the rear with the 8 screws (5).



#### Important



Gently move the lifting gear back and forth before tightening. This will ensure that the lifting gear does not tilt, but is still easily accessible even after tightening.

8. Tighten the clamping block (3) using the screws (4). This can be accessed through the machine head.



#### Order

After mechanical work on the sewing foot lifting gear, always calibrate the sewing feet via software:

- OP3000 ( p. 80)
- OP7000 ( p. 104)

## 12 Disassembling and assembling the electric thread tension

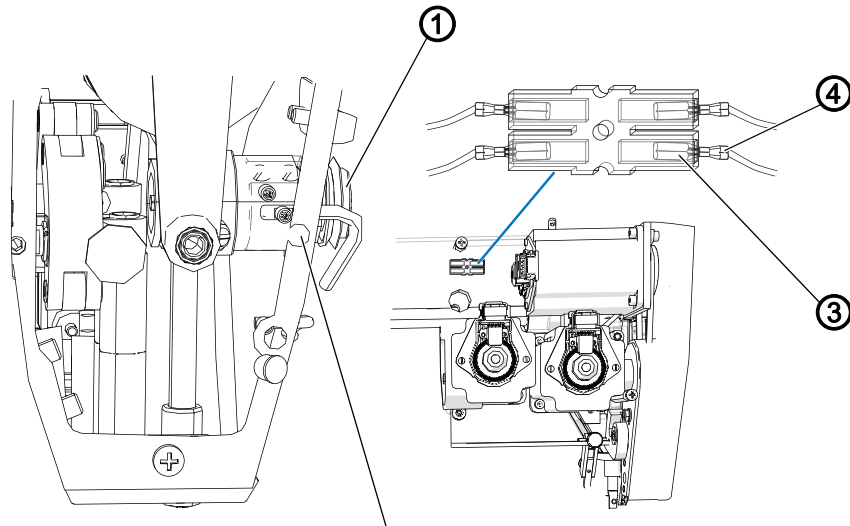


### Cover

- Disassemble the head cover (📖 p. 16)
- Disassemble the rear machine arm cover (📖 p. 17)

### Disassembling the electric thread tension

Fig. 33: Disassembling the electric thread tension



(1) - Electric thread tension  
(2) - Access hole

(3) - Plug  
(4) - Cable shoe



To disassemble the electric thread tension:

1. Loosen the threaded pin through the access hole (2) in the front side of the machine housing.
2. Pull out the electric thread tension (1) approx. 1 cm and turn counter-clockwise so that the cables point downwards and can be pulled out through the cable cutout.



### Important

Pull out the electric thread tension carefully so as not to damage the cable!

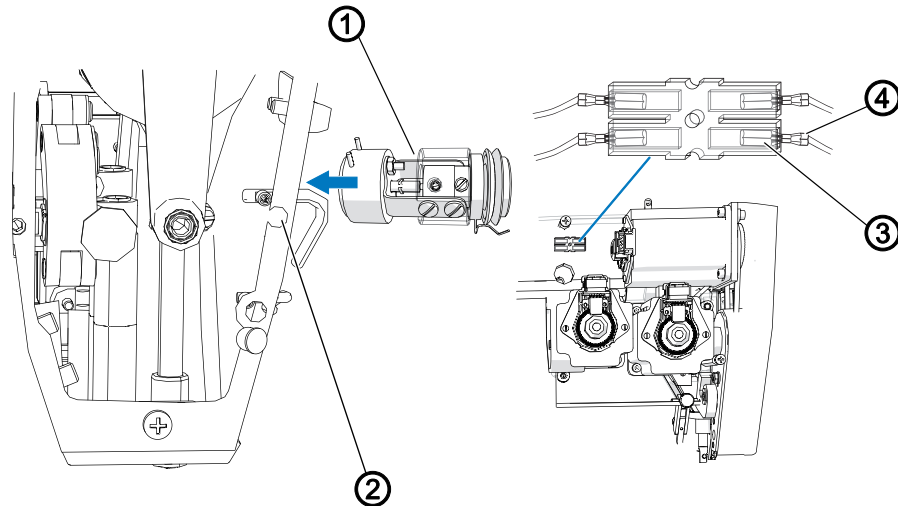
3. Pull the electric thread tension (1) forward as far as the length of the cable allows.

You can now adjust the following settings:

- Check the sewing foot lifting gear (📖 p. 49)
- Change the thread tensioning spring (📖 p. 54)
- Adjust the spring tension (📖 p. 57)

**Only when installing a new electric thread tension:**


4. Remove the cable shoe (4) from the transparent plug (3) on the rear of the stepper motor.
5. Carefully remove the electric thread tension (1) forward together with the cables.

**Assembling the electric thread tension**
*Fig. 34: Assembling the electric thread tension*


(1) - Electric thread tension  
(2) - Access hole

(3) - Plug  
(4) - Cable shoe



To assemble the electric thread tension:

1. Feed the cable of the electric thread tension (1) through the opening in the machine arm and backwards towards the transparent plug (3).
2. Insert the electric thread tension (1).
3. Insert the cable shoe (4) into the transparent plug (3).
4. Lay cables that are too long in loops such that moving machine parts are not impaired in their ability to function correctly.
5. Tie the cable loops together using a cable tie.
6. Tighten the threaded pin through the access hole (2) in the front side of the machine housing.



**Information**

If you receive a new thread tension as a spare part from Dürkopp Adler, this will already be pre-calibrated. The adjusting wheel for the spring tension is sealed.

You only need to enter the values for calibration positions 2 and 1 as indicated on the sticker on the machine head via software:

- OP3000 (📖 p. 80)
- OP7000 (📖 p. 104).

Adjust the thread tension for thread cutting via software:

- OP3000 (📖 p. 71)
- OP7000 (📖 p. 98)

**12.1 Changing the thread tensioning spring**

The thread tensioning spring holds the needle thread under tension until the tip of the needle has penetrated the sewing material.

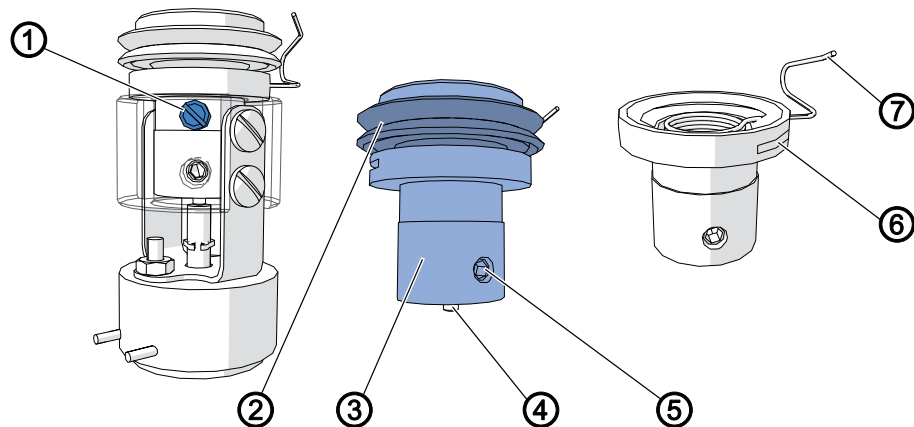


**Cover**

- Disassemble the head cover (📖 p. 16)

**Disassembling the thread tensioning spring**

Fig. 35: Disassembling the thread tensioning spring



- |                      |                                |
|----------------------|--------------------------------|
| (1) - Threaded pin   | (5) - Threaded pin             |
| (2) - Tension disks  | (6) - Slot                     |
| (3) - Inner cylinder | (7) - Thread tensioning spring |
| (4) - Release pin    |                                |



To disassemble the thread tensioning spring:

1. Disassemble the electric thread tension (📖 p. 52).
2. Loosen the threaded pin (1).
3. Remove the entire inner cylinder (3).





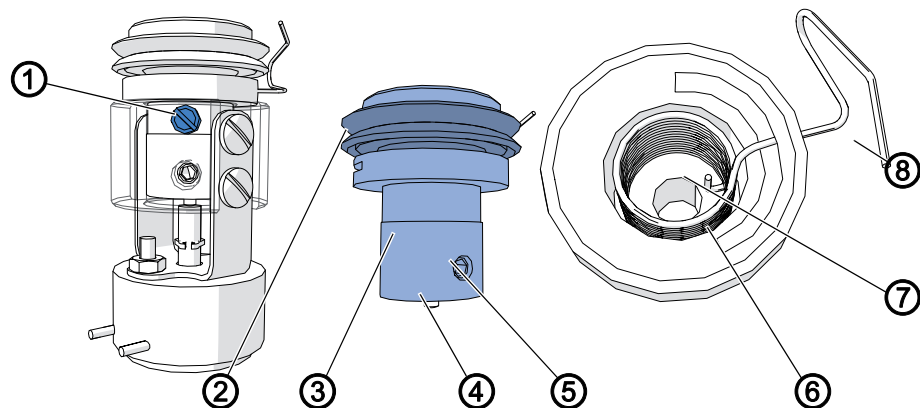
**Important**

Do not lose the release pin (4) when doing so!

4. Loosen the threaded pin (5).
5. Remove the tension bolt together with the tension disks (2).
6. Loosen the thread tensioning spring (7) from the cylinder.  
To do so, use a screw driver to remove the spring thread from the inner part.
7. Pull the open end of the thread tensioning spring through the slot (6).

**Assembling the thread tensioning spring**

Fig. 36: Assembling the thread tensioning spring (1)



- |                      |                                |
|----------------------|--------------------------------|
| (1) - Threaded pin   | (5) - Threaded pin             |
| (2) - Tension disks  | (6) - Slot                     |
| (3) - Inner cylinder | (7) - Hook                     |
| (4) - Release pin    | (8) - Thread tensioning spring |



To assemble the thread tensioning spring:

1. Pull the loose end of the thread tensioning spring (8) through the slot (6).
2. Insert the thread tensioning spring (8) into the cylinder.
3. Insert the tension bolt with the tension disks in the cylinder (2) and put the groove on the hook (7) of the thread tensioning spring.
4. Tighten the threaded pin (5).
5. Insert the inner cylinder (2) in the housing of the thread tension.



**Important**

The release pin (4) must be at the bottom of the cylinder.

6. Tighten the threaded pin (1).
7. Insert the thread tension (📖 p. 52).



**Important**

Leave the tension disks on the tension bolt.

If the tension disks have been removed, recalibrate the thread tension via software:

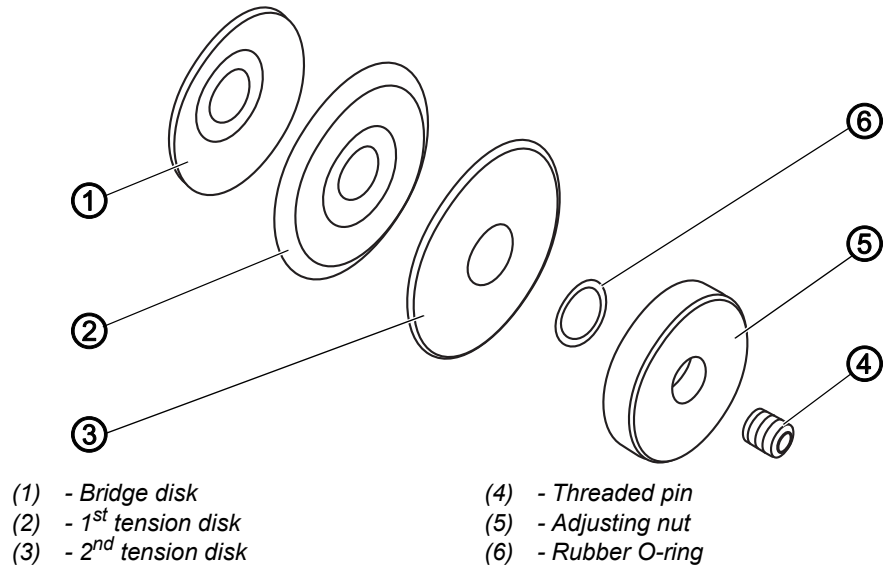
- OP3000 (📖 p. 80)
- OP7000 (📖 p. 104)



**Order of the tension disks**

If the tension disks have been removed from the tension bolt, put the elements back on in the following order:

*Fig. 37: Assembling the thread tensioning spring (2)*



## 12.2 Adjusting the spring tension



### Proper setting

The spring tension is between 20 and 50 cN (1 cN = 1 g).  
The exact setting depends on the sewing material and the thread thickness.



### Cover


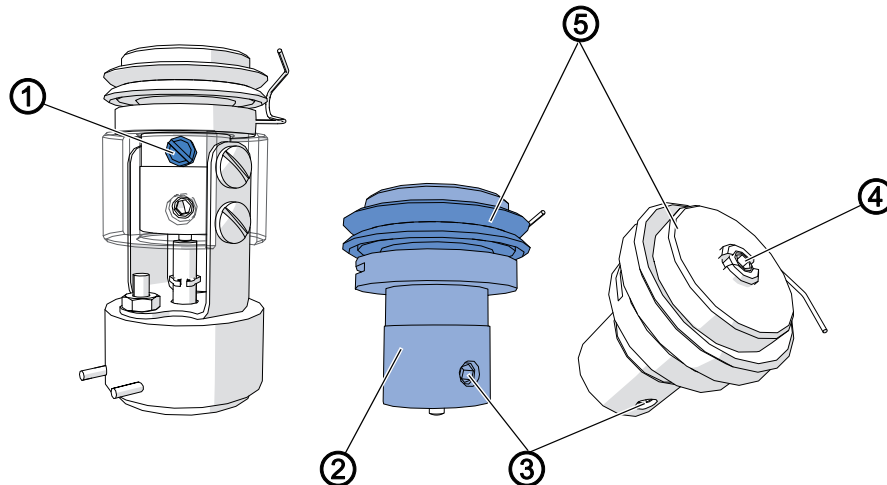
- Disassemble the head cover ( p. 16)

Fig. 38: Adjusting the spring tension





- (1) - Threaded pin  
(2) - Inner cylinder  
(3) - Threaded pin

- (4) - Tension bolt  
(5) - Tension disks



To adjust the spring tension:

- Disassemble the electric thread tension ( p. 52).
- Loosen the threaded pin (1).
- Pull the inner cylinder (2) out of the thread tension.
- Loosen the threaded pin (3).
- Twist the tension bolt (4) with the tension disks (5):
  - **increased tension:** turn clockwise
  - **decreased tension:** turn counterclockwise
- Tighten the threaded pin (3).
- Insert the inner cylinder (2) in the thread tension.
- Tighten the threaded pin (1).
- Assemble the electric thread tension ( p. 52).

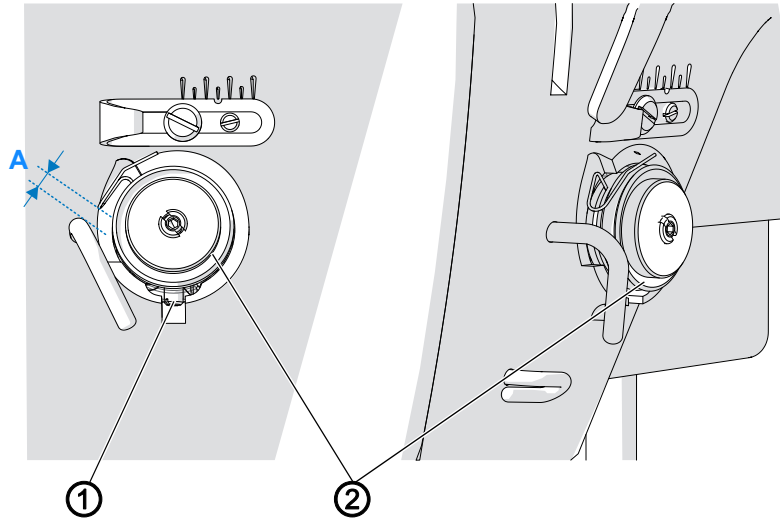
### 12.3 Adjusting the spring travel



#### Proper setting

The recommended length for spring travel (1) is 6.5 mm.  
The exact setting depends on the sewing material and the thread thickness.

Fig. 39: Adjusting the spring travel



**A** - Spring travel  
(1) - Threaded pin

(2) - Socket



To adjust the spring travel:

1. Loosen the threaded pin (2).
2. Turn the entire socket (3) until the desired spring travel is reached:
  - **shorter spring travel (A):** turn clockwise
  - **longer spring travel (A):** turn counterclockwise
3. Tighten the threaded pin (2).

## 12.4 Adjusting the needle thread regulator

The needle thread regulator determines the needle thread quantity to be guided around the hook. The required thread quantity depends on the thickness of the sewing material, the thread strength, and the stitch length.

### Larger thread quantity for

- thick sewing material
- high thread strengths
- large stitch lengths

### Lower thread quantity for

- thin sewing material
- low thread strengths
- small stitch lengths



### Proper setting

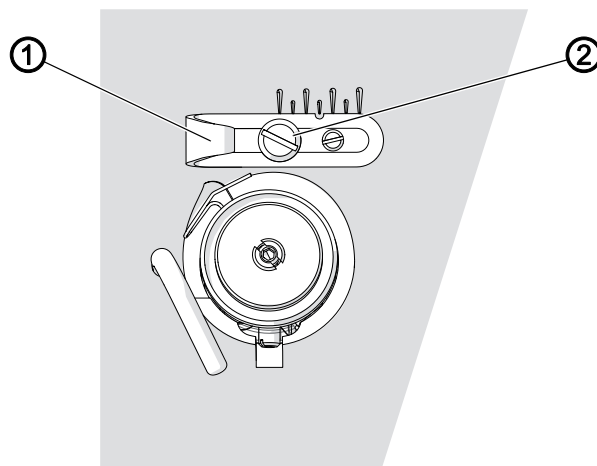
The needle thread loop runs without surplus and without jumping over the largest hook diameter.



### Disturbance

- Incorrect stitch formation

Fig. 40: Adjusting the needle thread regulator



(1) - Needle thread regulator

(2) - Screw



To adjust the needle thread regulator:

1. Turn the handwheel and observe the cycle of the needle thread around the hook.
2. Loosen the screw (2).
3. Move the needle thread regulator (1):
  - **larger needle thread quantity:** Slide the needle thread regulator to the left
  - **smaller needle thread quantity:** Slide the needle thread regulator to the right
4. Tighten the screw (2).

## 13 Winder

### 13.1 Adjusting the bobbin filling quantity



#### Proper setting

After winding, the winding process stops automatically if the bobbin is filled to approx. 0.5 mm under the edge of the bobbin.

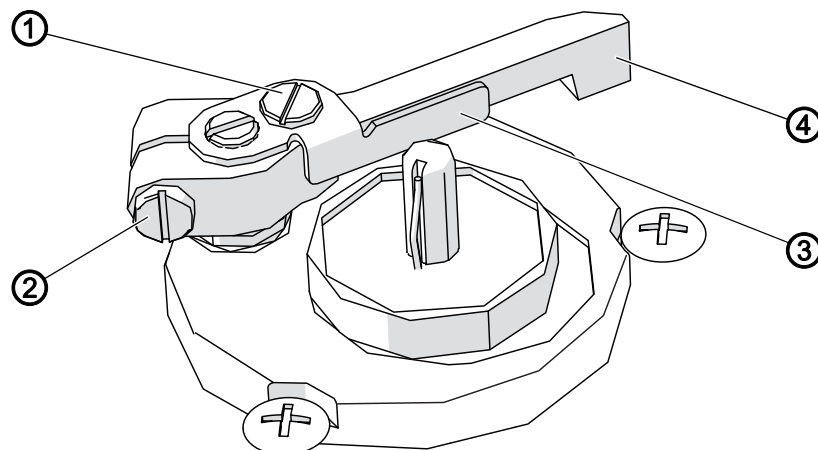
#### NOTICE

#### Property damage from winding without performing sewing!

When running without sewing material, sewing feet and the bobbin capsule can be damaged in the hook.

Activate winder mode and take the bobbin capsule out of the hook when you run the test winding process.

Fig. 41: Adjusting the bobbin filling quantity



(1) - Adjusting wheel  
(2) - Clamping screw

(3) - Thread guide plate  
(4) - Actuating lever

#### Rough setting



To roughly set the winder filling quantity:

1. Loosen the clamping screw (2).
2. Actuate lever (4) alignment:
  - **Smaller bobbin filling quantity:** Slide the actuating lever (4) towards the bobbin
  - **Larger bobbin filling quantity:** Slide the actuating lever (4) away from the bobbin
3. Tighten the clamping screw (2).

### Fine adjustment



To accurately adjust the winder filling quantity:

1. Loosen the adjusting wheel (1).
2. Move the thread guide plate (3):
  - **Smaller bobbin filling quantity:** Slide the thread guide plate (3) towards the bobbin
  - **Larger bobbin filling quantity:** Slide the thread guide plate (3) away from the bobbin
3. Tighten the adjusting wheel (1).

### 13.2 Adjusting the winding form

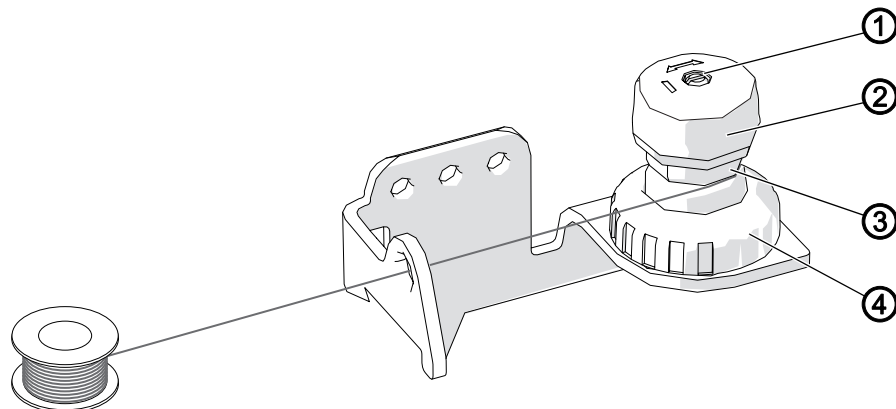
The height of the gap determines how the hook thread is wound onto the bobbin.



#### Proper setting

The thread is wound on evenly over the entire height of the bobbin. The thread runs in a straight line, without any buckling, from the gap through the thread guide to the bobbin.

Fig. 42: Adjusting the winding form



(1) - Guide pin

(2) - Adjusting knob

(3) - Gap

(4) - Knurled nut



To adjust the winding form:

1. Loosen the knurled nut (4).
2. Turn the guide pin (1) with a flat-head screw driver:
  - **Set the gap (3) lower:** turn clockwise
  - **Set the gap (3) higher:** turn counterclockwise



#### Important

When doing so, do not turn the setting button (2)!

3. Tighten the knurled nut (4).

### 13.3 Adjusting the winding tension



#### Proper setting

The correct tension during winding depends on the sliding properties and the thickness of the thread.



#### Disturbance

- Ruffling on the seam
- Incorrect stitch formation



## 14 Programming (OP3000)

This chapter describes service settings:

- Presettings for sewing programs and functions
- Basic machine settings
- Advanced machine settings
- Test functions for individual elements in the machine
- Calibration functions
- Initializing the machine

### 14.1 Calling up the Technician level

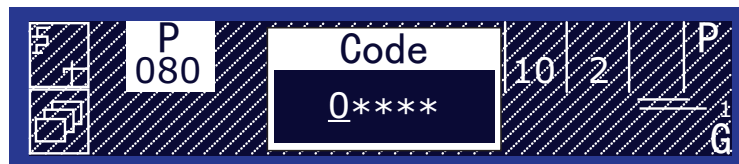
All settings in the service menu must be carried out at the *Technician level*.



#### Important

For safety reasons, the pedal at the Technician level is not active! While you can test the pedal input in the *Multitest* sub-item, the sewing motor is not activated by the pedal.

Fig. 43: Calling up the Technician level (1)



To select the Technician level:

1. Press and hold the buttons **P** and **S** at the same time.
- ↪ The input mask for the code appears on the display:
2. Enter code 25483 using the numeric keys.
- ↪ Each time a number is entered, the input cursor will automatically jump to the next position. The numbers are not shown for safety reasons. A 0 appears at the relevant entry point; asterisks are in the other positions.  
Use ◀▶ to move from one entry point to another.

Immediately after the code is entered, the display shows the menu items at the Technician level.

Fig. 44: Calling up the Technician level (2)



### Establishing access after an error message

After some error messages, it may happen that menus or sewing programs can no longer be called up. After being switched off or on, the machine also displays the error message during start up and will not continue to the sewing programs.

In this case, there is an option to go directly to the Technician level during machine start up in order to carry out a error diagnosis using *Multitest* or to reset the machine to the delivery state using *Reset*.




To provide access after an error message:


1. Switch off the machine.
2. Keep the **F** button pressed down and switch on the machine.
  - ↳ The machine starts up, and the display shows the input mask for the code.
3. Enter code 25483.
  - ↳ Only the following sub-items are available:
    - *Multitest*: Tests for error diagnosis (📖 p. 76)
    - *Reset*: Initialize machine to delivery state (📖 p. 85)


## 14.2 Menu items at the Technician level


The following table provides an overview of the structure of the service menu.

### Structure of the OP3000 service menu

Menu items					
Menu item	Numerical	Function	Sub-item	Sub-item	Reference
Default Program	1.0	Presettings which are applicable to all sewing programs			 p. 69
	1.1		Stitchlen.		
	1.2		Curve		
	1.3		Foot Press		
	1.4		Thr.Tens.		
	1.5		FullnessType		
	1.6		Fullness		
	1.7		Foot Stroke		
	1.8		Start Tack		
	1.9		End Tack		
	1.10		Thread Trim		
	1.11		Teach Side		
	1.12		Action		

Menu items					
Menu item	Numerical	Function	Sub-item	Sub-item	Reference
<b>Machine config.</b>	2.0	Specify basic machine settings which are applicable to all sewing programs			 p. 71
	2.1		Start Tack		
	2.1.1			Repetitions	
	2.1.2			t Change	
	2.1.3			Stitches ↑	
	2.1.4			Stitches ↓	
	2.1.5			Speed	
	2.2			End Tack	
	2.2.1		Repetitions		
	2.2.2		t Change		
	2.2.3		Stitches ↑		
	2.2.4		Stitches ↓		
	2.2.5		Speed		
	2.3		Thread Trim		
	2.3.1			Speed	
	2.3.2			Thr.Tens.	
	2.3.3		Turn Back		
	2.4		Speed		
	2.4.1			Max. Speed	
	2.4.2			Min. Speed	
	2.4.3			Pos. Speed	
	2.4.4			Soft Speed	
	2.4.5			N Stitches	
	2.5		Stop Positions		
	2.5.1			StopIdle°	
	2.5.2			StopTop°	
	2.5.3		StopBottom°		
	2.6		Foot		
	2.6.1			FL AtStop	
	2.6.2			FL AfterTrim	
	2.6.3			FL height	
	2.7		Thr.Tens.		
	2.7.1			PreTension	
2.7.2	t After Sew				

Menu items					
Menu item	Numerical	Function	Sub-item	Sub-item	Reference
	2.8		Pedal		
	2.8.1			Type	
	2.8.2			Inverted	
	2.8.3			Curve	
	2.8.4			N StepsPedal	
	2.8.5			t Posit. 0	
	2.8.6			t Posit. -1	
	2.8.7			t Posit. -2	
<b>User config.</b>	3.0	Specify advanced machine settings			 p. 75
	3.1		Language		
	3.2		Forward Sound		
	3.3		AutoForwSide		
	3.4		Pedal Abort		
	3.5		Pedal 2		
	3.6		Brightness		
	3.7		Contrast		

Menu items					
Menu item	Numerical	Function	Sub-item	Sub-item	Reference
<b>Service</b>	4.0	Test functions, calibration, initialize/ transfer data			 p. 76
	4.1		Multitest		
	4.1.1			Test Output	
	4.1.2			Test PWM	
	4.1.3			Test Input	
	4.1.4			Test Auto Input	
	4.1.5			Test Sew. Motor	
	4.1.6			Test Step. Motor	
	4.1.7			Test Pedal	
	4.2			Calibration	
	4.2.1		Feed Sync.Top		
	4.2.2		Foot Calib		
	4.2.3		Thread Calib.		
	4.2.4		Pedal		
	4.3		Reset		
	4.3.1			Reset Data	
	4.3.2			Reset programs	
	4.3.3		Reset All		
	4.4		Data Transfer		
	4.4.1			All Data	
	4.4.2			Programs	

### 14.3 Menu item *Default Program*

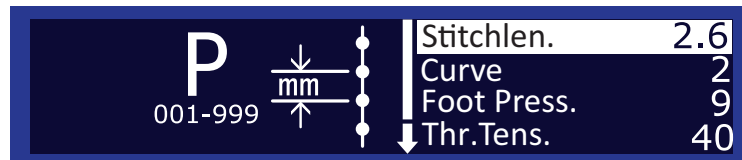
You use the menu item *Default Program* to define the values that will be preset when a new sewing program is created.



To define the preset values:

1. Select *Default Program* in the service menu.
- ↳ The following appears on the display:




Fig. 45: Menu item *Default Program*



2. Select the desired parameter.
3. Enter values that reflect your sewing requirements and can be retained in as many sewing programs as possible in order to make the process of creating new sewing program simple.

#### Parameters in the menu item *Default Program*

Icon	Entry	Meaning	Possible value range	Preset value
	<b>Stitchlen.</b>	Stitch length	1.0 – 4 mm	2.5
	<b>Curve</b>	Curve support	0 – 6	2
	<b>Foot Press</b>	Sewing foot pressure	1 – 10	5
	<b>Thr.Tens.</b>	Thread tension	1 – 99	40
	<b>FullnessType</b>	Fullness Top/Bottom	↑ = top ↓ = bottom	↑
	<b>Fullness</b>	Fullness	-6 – 16	0
	<b>Foot Stroke</b>	Alternation: The sewing foot is lifted by this height for each stitch	0 – 2.5 mm	0
	<b>Start Tack</b>	Start bartack	0 = No bartack 1 = Bartack on	0
	<b>End Tack</b>	End bartack	0 = No bartack 1 = Bartack on	0

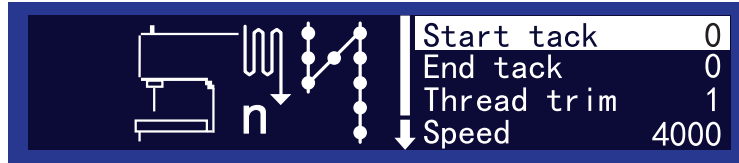
Icon	Entry	Meaning	Possible value range	Preset value
	<b>Thread Trim</b>	Thread trimmer	0 = off 1 = on	1
	<b>Teach Side</b>	Sleeve side which is programmed first	R = Start with right sleeve L = Start with left sleeve	R
	<b>Action</b>	Action after programming the 1 <sup>st</sup> sleeve in order to create the 2 <sup>nd</sup> sleeve side	<i>nothing</i> = no 2 <sup>nd</sup> sleeve side <i>mirror</i> = mirror sleeve side <i>teach</i> = program 2 <sup>nd</sup> sleeve side <i>ask</i> = selection mask for <i>nothing</i> , <i>mirror</i> or <i>teach</i>	mirror



### 14.4 Menu item *Machine config.*

The menu item *Machine config.* allows you to determine the basic settings for the machine which apply to all programs.

Fig. 46: Menu item *Machine config.*



#### 14.4.1 Sub-item *Start Tack*

In the *Start Tack* sub-item, you can define how the start bartack is sewn.

Fig. 47: Sub-item *Start Tack*



#### Parameters in the *Start Tack* sub-item

Icon	Entry	Meaning	Possible value range	Preset value
	<b>Repetitions</b>	Number of repetitions per bartack	1 – 10	2
	<b>t Change</b>	Waiting time when switching between forward and backward stitch	0 – 1000	0
	<b>Stitches ↑</b>	Number of forward stitches per bartack	1 – 50	3
	<b>Stitches ↓</b>	Number of backward stitches per bartack	1 – 50	3
	<b>Speed</b>	Speed when sewing the bartack	50 – 2000	1000

#### 14.4.2 Sub-item *End Tack*

The sub-item *End Tack* matches the sub-item *Start Tack* ( p. 71).

You can adjust the same settings here for the end bartack.

### 14.4.3 Sub-item *Thread Trim*

In the *Thread Trim* sub-item, you can define the settings for cutting the thread.

Fig. 48: Sub-item *Thread Trim*



#### Parameters in the *Thread Trim* sub-item

Icon	Entry	Meaning	Possible value range	Preset value
	<b>Speed</b>	Speed when cutting the thread	50 – 250	180
	<b>Thr.Tens.</b>	Thread tension during thread cutting: The larger the value, the shorter the thread will be cut	1 – 99	10
	<b>Turn Back</b>	Automatic reversal after cutting the thread	0 = off 1 = on	1

### 14.4.4 Sub-item *Speed*

In the *Speed* sub-item, you can define the speed in certain situations.

Fig. 49: Sub-item *Speed*



#### Parameters in the *Speed* sub-item

Icon	Entry	Meaning	Possible value range	Preset value
	<b>Max. speed</b>	Maximum speed when fully stepping on the pedal in $\text{min}^{-1}$	500 – 4000	4000
	<b>Min. Speed</b>	Minimum speed in $\text{min}^{-1}$	50 – 400	150

Icon	Entry	Meaning	Possible value range	Preset value
	<b>Pos. Speed</b>	Speed when positioning in min <sup>-1</sup>	10 – 700	400
	<b>Soft Speed</b>	Speed on soft start in min <sup>-1</sup>	10 – 1000	500
	<b>N Stitches</b>	Number of soft start stitches	1 – 10	1

#### 14.4.5 Sub-item *Stop Positions*

In the *Stop Positions* sub-item, you can determine the position of the needle when sewing stops.

The position is specified by entering degree values.

The position is 0° when the needle is at top dead center. The remaining handwheel positions can be inferred accordingly. 360° corresponds to one complete handwheel rotation.

Fig. 50: Sub-item *Stop Positions*



#### Parameters in the *Stop Positions* sub-item

Icon	Entry	Meaning	Possible value range	Preset value
	<b>StopIdle°</b>	Handwheel position after cutting the thread and reversal	0 – 359	35
	<b>StopTop°</b>	Handwheel position in the needle's upper idle position when sewing stops	0 – 359	0
	<b>StopBottom°</b>	Handwheel position in the needle's lower idle position when sewing stops	0 – 359	130

#### 14.4.6 Sub-item *Foot*

In the *Foot* sub-item, you can define the settings for sewing foot lift.

Fig. 51: Sub-item *Foot*



#### Parameters in the *Foot* sub-item

Icon	Entry	Meaning	Possible value range	Preset value
	<b>FL AtStop</b>	Sewing foot lift when sewing stops	0 = off 1 = on	0
	<b>FL AfterTrim</b>	Sewing foot lift after cutting the thread	0 = off 1 = on	0
	<b>FL height</b>	Sewing foot position when raised	5 – 14	12

#### 14.4.7 Sub-item *Thr. Tens.*

In the *Thr. Tens.* sub-item, you can define the settings for the thread tension.

#### Parameters in the *Thr. Tens.* sub-item

Entry	Meaning	Possible value range	Preset value
<b>PreTension</b>	Current feed to the thread tension during the cutting process. Not used if thread is pretensioned mechanically	0 – 99	0
<b>t After Sew</b>	The thread tension remains closed for a defined period of time after thread cutting, thereby preventing the needle thread from being pulled further when the sewing material is removed	0.1 – 7.5	5.0

#### 14.4.8 Sub-item *Pedal*

In the *Pedal* sub-item, you can define the settings for the pedal.

#### Parameters in the *Pedal* sub-item

Entry	Meaning	Possible value range	Preset value
<b>Type</b>	Selection of pedal	<ul style="list-style-type: none"> <li>• DA Analog</li> <li>• Digital</li> </ul>	DA Analog
<b>Inverted</b>	Inverting signals of the digital pedal	0 = on 1 = off	1
<b>Curve</b>	Speed curve	0 – 7	0
<b>N StepsPedal</b>	Number of speed levels of pedal	0 – 64	24
<b>t Posit. 0</b>	Debouncing of position 0	0 – 255	5
<b>t Posit. -1</b>	Debouncing of position -1	0 – 255	50
<b>t Posit. -2</b>	Debouncing of position -2	0 – 255	15





#### 14.5 Menu item *User config.*

The menu item *User config.* allows you to define additional machine settings.

Fig. 52: Menu item *User config.*



#### Parameters in the menu item *User config.*

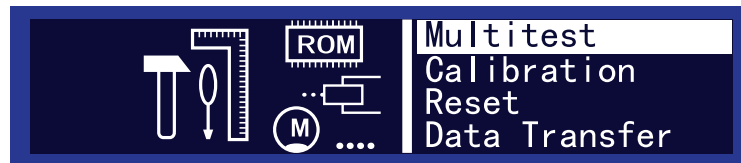
Icon	Entry	Meaning	Possible value range	Preset value
	<b>Language</b>	Language	0 = English 1 = French 2 = German	0
	<b>Forward Sound</b>	Signal tone when transitioning between program steps	0 = off 1 = on	1
	<b>AutoForwSide</b>	Automatic change of side between right/left when sewing	0 = off 1 = on	1
	<b>Pedal Abort</b>	Program termination with main pedal	0 = off 1 = on	1

Icon	Entry	Meaning	Possible value range	Preset value
	<b>Pedal 2</b>	Function of the optional additional pedal	~ = Modification of fullness Curve = Modification of curve support	±
	<b>Brightness</b>	Control panel brightness	0 – 255	224
	<b>Contrast</b>	Control panel contrast	0 – 255	32

### 14.6 Menu item *Service*

In the menu item *Service*, you can perform function tests, calibrate or reset the machine to its delivery state.

Fig. 53: Menu item *Service*



The sub-items have further sub-items ( p. 65).

#### 14.6.1 Sub-item *Multitest*

##### WARNING



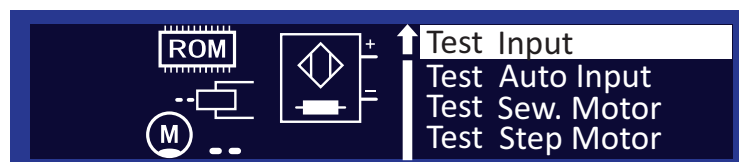
**Risk of injury from moving, cutting and sharp parts!**

Crushing, cutting and punctures are possible.

Exercise the utmost caution when performing tests when the machine is running.

In the *Multitest* sub-item, you can test whether certain elements are functioning.

Fig. 54: Sub-item *Multitest*



**Test Output**

In this machine, this sub-item has no function.

**Test PWM**

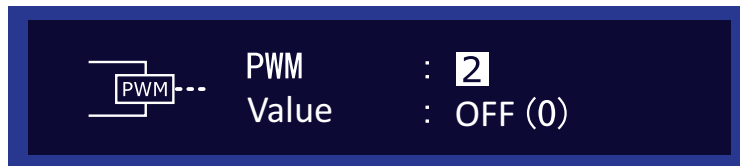
In the *Test PWM* sub-item, you can test the magnets for the thread trimmer.



To test the magnets for the thread trimmer:

1. Use ▲/▼ in the *PWM* field to choose the element that you wish to test:
  - **2 = Thread trimmer magnet**

Fig. 55: *Test PWM*



2. Press the **OK** button.
  - ↳ The display under *Value* switches between *ON* and *OFF*.
3. Watch the thread trimmer and check if a press on **OK** actually triggers the thread trimmer (📖 p. 28).

**Test Input**

In the *Test Input* sub-item, you can test the individual input elements.

Fig. 56: *Test Input*



To perform the input test:



1. Use ▲/▼ in the *Input* field to choose the element that you wish to test.
2. Actuate the element as described in the **Action** column (see table below).
3. Observe the display.
  - ↳ If the element is functional, the display switches between *ON* and *OFF* under *Value*.

**Test Input**

Input	Element	Action
1	Tilt sensor	• Tilting and re-erecting the machine head.
9*	Knee lever in switch position 1*	• Press against the knee lever.
10*	Knee lever in switch position 2*	• Press against the knee lever.
* It will suffice to test the knee lever in one of the two switch positions.		

**Test Auto Input**

In the sub-item *Test Auto Input* you can carry out the same tests as under *Test Input* without having to select the element beforehand via the display.

Fig. 57: Test Auto Input



To perform the automatic input test:

1. Actuate the element as described in the **Action** column.
- ↳ In *Input*, the display shows the number of the element last changed.  
If the element is functional, the display switches between *ON* and *OFF* under *Value*.

**Test Auto Input**

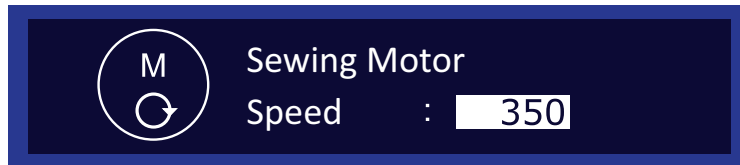
Input	Element	Action
1	Tilt sensor	• Tilting and re-erecting the machine head.
9*	Knee lever in switch position 1*	• Press against the knee lever.
10*	Knee lever in switch position 2*	• Press against the knee lever.
* It will suffice to test the knee lever in one of the two switch positions.		



**Test Sew. Motor**

In the *Test Sew. Motor* sub-item, you can test the sewing motor.

Fig. 58: *Test Sew. Motor*



To test the sewing motor:

1. Press the **OK** button.
- ↳ The machine performs a reference run.
2. In *Speed*, use ▲/▼ to enter a speed in steps of 50.
3. Press the **OK** button.
- ↳ The motor runs at the entered speed.
4. Press **ESC** key to end.

**Test Step.Motor**

In the *Test Step Motor* sub-item, you can test the stepper motors for sewing feet and conveyor belts.

Fig. 59: *Test Step.Motor*



To test the stepper motor:

1. Use ▲/▼ in the *Stepper* field to choose the motor that you wish to test.
2. Press the **OK** button.
3. Use ▲/▼ to test the respective motor.
- ↳ If the motor is functioning correctly, the behavior described in the table will be shown.

### Test Stepper Motor

No.	Motor	Correct function
1	Upper drive for both conveyor belts	The belts move.
2	Height of the upper right walking foot	The height changes.
3	Height of the upper left walking foot	The height changes.
4	Lower drive for both conveyor belts	The belts move.




#### Information

There is no specific procedure for testing the stepper motor encoders. The encoders are tested along with the stepper motors. If the result for the stepper motors is *OK*, the encoders will be functional as well.

### 14.6.2 Menu item *Calibration*






In the *Calibration* sub-item, you can calibrate the machine.

#### *Feed Sync.Top*

In the *Feed Sync.Top* sub-item, you can set the evenness of the top and bottom feed. Correction is required after you have changed the conveyor belts ( p. 39).



To test the differential top feed:


1. Switch off the machine.
2. Remove the needle.
3. Switch on the machine.
4. Switch to manual mode ( *Operating Instructions*).
5. Use   to select the *Curve Support* parameter.
6. Use  to enter a value of 0 as the curve support.
7. Use the numeric buttons to enter 0 for the fullness.
8. Place 2 congruent boards one above the other on the sewing material support surface.
9. Step on the pedal and observe the feed rate of the boards:
  -  Both boards must be fed without offset.

If the boards are not fed without offset, correct the differential top feed.

Fig. 60: Feed Sync. Top



Correct the differential top feed as follows:

1. Establish access to the Technician level ( p. 63).
2. Select the menu item *Service*.
3. Select the *Calibration* sub-item.
4. Select the *Feed Sync. Top* sub-item.
- ↳ An input field with a numerical value is displayed on the right.
5. Use ▲/▼ to change the value in this field:
  - **Increase top feed:** Increase value
  - **Reduce top feed:** Reduce value
6. Perform the test with the boards again.
7. Repeat steps 1 – 6 again if necessary.



### *Foot Calib*


The control must know the upper and lower position of the sewing feet. The upper position is communicated when switching on the machine.

The lower position is defined by calibration in the *Foot Calib* sub-item.

Fig. 61: Foot Calib



### **Order**

Always calibrate the sewing feet after making adjustments to the sewing foot lifting gear ( p. 49).



Calibrate the sewing feet as follows:

1. Select the *Foot Calib* sub-item.
2. Press the **OK** button.
- ↳ The machine will calibrate automatically:  
Both sewing feet will lift once and then lower again.  
The calibration is then complete.

**Thread Calib.**

In the *Thread Calib.* sub-item, you can calibrate the electronic thread tension.

Prerequisite: An external thread tension measurement device is available, and the calibration is performed with a thread with a thickness of 120.



**Important**

The thread tension has been set at the factory both mechanically and electronically.

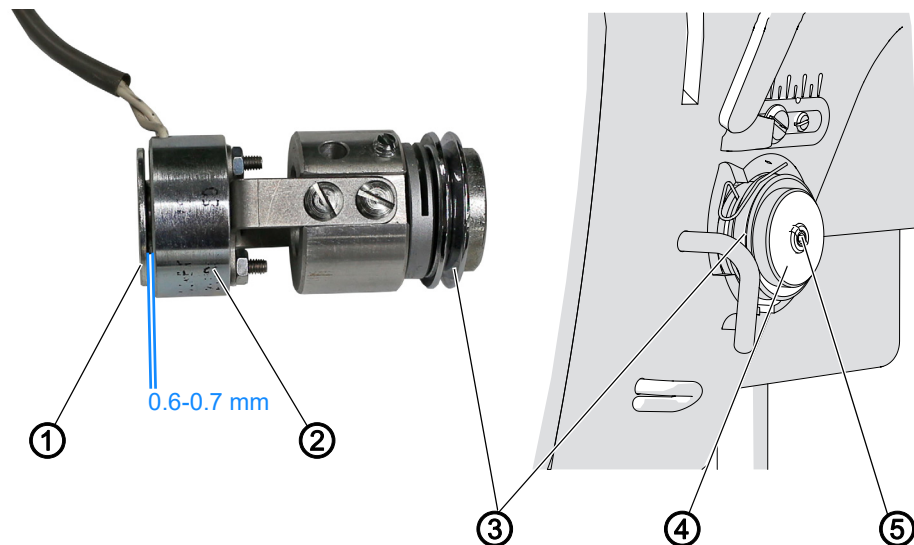
After a complete reset or installing new software, the calibration values remain the same.

After a change of the control, the calibration values **ONLY** have to be entered again if the existing machine ID will **NO** longer be used.

After a change of the control, you should check if the calibration values have been stored correctly in the control. You can find the correct values on the sticker located on the underside of the base plate. You will be able to see the sticker after tilting the machine head (📖 p. 15).

If it needs to be disassembled, the electronic thread tension must be calibrated again after its reassembly (📖 p. 56) - first mechanically and then electronically.

Fig. 62: Thread Calib. (1)



- (1) - Moving piston
- (2) - Magnet
- (3) - Tension disks

- (4) - Adjusting nut
- (5) - Threaded pin



To calibrate the electronic thread tension **mechanically**:

1. Loosen the threaded pin (5).
  2. Turn the adjusting nut (4).
- 👉 The gap between the moving piston (1) and the magnet (2) must be 0.6 to 0.7 mm.

Fig. 63: Thread Calib. (2)



1. Open the menu *Service* > *Calibration* and select the *Thread Calib.* sub-item.

Fig. 64: Thread Calib. (3)



2. Insert the needle thread and guide it up to the thread lever.
3. After the thread lever, feed the needle thread into the external thread tension measurement device.



4. Select *calibration position 3* and measure the tension.

↳ The tension should be 300 g.

5. If the tension is not 300 g, press the **OK** button.

↳ The tension switches off.



6. Turn the adjusting nut (4).

- **To reduce the tension:** Turn the adjusting nut (4) clockwise; the gap between the moving piston (1) and the magnet (2) widens
- **To increase the tension:** Turn the adjusting nut (4) counterclockwise; the gap between the moving piston (1) and the magnet (2) narrows



7. Press the **OK** button.

↳ The tension switches on.

8. Measure the tension and repeat the process as many times as necessary for the tension to equal 300 g.



9. Tighten the threaded pin (5).

↳ The adjusting nut (4) is blocked.

10. Check if the switched-on tension equals 300 g.



### Order

After setting the basic tension mechanically, the calibration values 2 and 1 must be adjusted electronically.

Set the following 3 calibration positions one after the other for the needle thread:

- Calibration position 3 - maximum tension (300 g)
- Calibration position 2 - medium tension (150 g)
- Calibration position 1 - minimum tension (5 g)



To calibrate the electronic thread tension **electronically**:

### Setting calibration position 2



1. Open the menu *Service > Calibration > Thread Calib.* and use the buttons ▲/▼ to select *Calibration position 2*.
2. Press the **OK** button.
  - ↳ The tension switches on.  
The tension should be 150 g.
3. If the thread tension is not 150 g, use the buttons ▲/▼ to adjust the tension until the measurement device displays the value 150 g.
4. Press the **OK** button.
  - ↳ The tension switches off.
5. Open the menu *Service > Calibration > Thread Calib.* again and use the buttons ▲/▼ to select *Calibration position 2*.
6. Check the tension value and readjust it if necessary.

### Setting calibration position 1



1. Open the menu *Service > Calibration > Thread Calib.* and use the buttons ▲/▼ to select *Calibration position 1*.
2. Press the **OK** button.
  - ↳ The tension switches on.  
The guideline value for calibration position 1 is 5 g.



3. Perform a tension test:  
The set value is correct if the difference that can be sensed between the switched-off and the switched-on tension is minimal.

### 14.6.3 Sub-item *Reset*

In the *Reset* sub-item, you can reset sewing programs and parameters to the delivery state. To do this, re-entering the code once is requested (for reasons of security).



To select the *Reset* sub-item:

1. Use ▲/▼ to select the *Reset* sub-item.
- ↳ The input mask for the code appears on the display.
2. Enter code 25483 using the numeric keys.
- ↳ *Reset* has the following sub-items:

Fig. 65: Sub-item *Reset*



#### *Reset Data*

In the *Reset Data* sub-item, you can reset all parameters to the delivery state.



To reset all parameters:

1. Use ▲/▼ to select *Reset Data*.
2. Press the **OK** button.
- ↳ All programs will be returned to their delivery state.

#### *Reset programs*

In the *Reset programs* sub-item, you can delete all the sewing programs you have created yourself.

Only the standard programs are retained and are returned to their delivery state.



To delete all the sewing programs you have created yourself:

1. Use ▲/▼ to select *Reset programs*.
2. Press the **OK** button.
- ↳ All the sewing programs you have created yourself will be deleted. The standard programs will be returned to their delivery state.

### **Reset All**

In the *Reset All* sub-item, you can reset all sewing programs and parameters to the delivery state.

Only the calibration values for the thread tension and sewing feet are retained.



To reset all sewing programs and parameters:

1. Use ▲/▼ to select *Reset All*.
  2. Press the **OK** button.
- ↳ All sewing programs and parameters (except for the calibration values for the thread tension and sewing feet) will be reset to their delivery state.

### **14.6.4 Sub-item Data Transfer**

The *Data Transfer* sub-item allows you to copy parameters and sewing programs to or from a USB key.



#### **Important**

When data is copied (from the control to USB or from USB to the control), the original data is erased from memory first before being completely overwritten with new data.

#### **Entries in the Data Transfer sub-item**

Entry	Meaning
<b>All Data</b>	Transfer all data
<b>Programs</b>	Transfer programs

The *Programs* sub-item matches the *All Data* sub-item.

#### **Entries in the All Data/Programs sub-item**

Entry	Meaning
<b>Store To USB</b>	Copy, save the active program to USB key
<b>Load From USB</b>	Load program from USB key



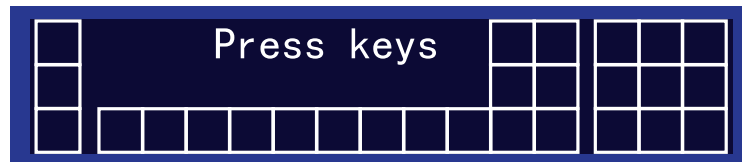
## 14.7 Testing the functionality of the keys on the control panel



To test the functionality of the keys on the control panel:

1. Switch off the machine.
  2. Keep the **ESC** button pressed down and switch on the machine.
- ↳ The display shows the following mask:

Fig. 66: Testing the functionality of the keys on the control panel (1)

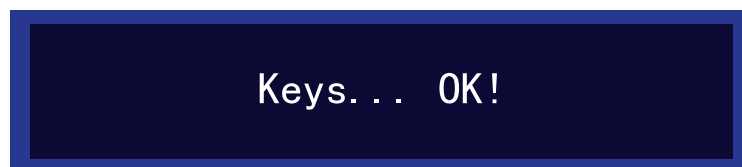


3. Press all keys on the control panel in any order except for **ESC**.
- ↳ If a button is functional, then the corresponding box on the display will be filled in (highlighted clearly).  
If the button is not functional, then the box stays empty.
4. Press the **ESC** button.

- **If all buttons are functional:**

↳ The display shows the following status report:

Fig. 67: Testing the functionality of the keys on the control panel (2)



5. Press the **OK** button.
- **If one or several buttons are not functional:**
- ↳ The status report *Keys... NOT OK!* appears on the display.  
The control panel has to be replaced.

## 14.8 Performing a software update



### Information

Machines with software versions up to and including **A 03.27** require that you perform a comprehensive, one-time update (bootloader update). Machines with software versions **A 03.29** do not require a bootloader update and can be updated immediately.

1. The bootloader software can be requested by emailing [service@duerkopp-adler.com](mailto:service@duerkopp-adler.com).
2. Unzip the file to a USB key.
  - ↳ This creates 2 folders: *bootscr* and *update*.
3. Plug the USB key (2) into the USB port (3) on the control (1).
4. Switch on the machine.
  - ↳ The update is launched. The LEDs (4) illuminate. The update is complete when only the POWER LED is lit.

Fig. 68: Performing a software update (1)



- (1) - Control  
(2) - USB key

- (3) - USB port  
(4) - LEDs




To perform the software update:

1. The machine-specific update can be requested by emailing [service@duerkopp-adler.com](mailto:service@duerkopp-adler.com).
  - ↳ The program is packaged as a .zip file whose name reflects the part number of the program, the software status and the date it was created, e. g. 9899\_0650\_700\_\*.\*\*\_YYY-MM-DD.zip

2. Uncompress the .zip file to a Dürkopp Adler USB key (part number 9835 301003).
  - ↳ The ending of the update file is *.dacing*.
3. Plug the USB key (2) into the USB port (3) on the control (1).
4. Switch on the machine.
  - ↳ The update is launched. The LEDs (4) illuminate.
  - ↳ The update is complete when only the POWER LED is lit.



**Important**

5. After updating an older software version to version **A 03.62**, calibrate the electronic thread tension ( p. 82).
  - ↳ The machine is ready for sewing.



## 15 Programming (OP7000)

This chapter describes service settings:

- Presettings for sewing programs and functions
- Basic machine settings
- Advanced machine settings
- Test functions for individual elements in the machine
- Calibration functions
- Initializing the machine

### 15.1 Calling up the Technician level

All settings in the service menu must be carried out at the Technician level.



#### Important

For safety reasons, the pedal at the Technician level is not active! While you can test the pedal input in the *Multitest* menu item, the sewing motor is not activated by the pedal.



To select the Technician level:

1. Press the **SERVICE** button.
- ↳ The input mask for the code appears on the display:

Fig. 69: Calling up the Technician level (1)



2. Enter the code 25483 using the keypad.
- ↳ Each time a number is entered, the input cursor will automatically jump to the next position. The numbers are not shown for safety reasons. A 0 appears at the relevant entry point; asterisks are in the other positions.
3. Press the **OK** button.
- ↳ After the code is entered, the display shows the menu items at the Technician level:

Fig. 70: Calling up the Technician level (2)






### 15.2 Menu items at the Technician level

The following table provides an overview of the structure of the service menu.




#### Structure of the OP7000 service menu

Menu items					
Menu item	Numerical	Function	Sub-item	Sub-item	Reference
Default Program Parameters	1.0	Specify presettings which are applicable to all sewing programs			p. 96
	1.1		Stitch Length		
	1.2		Curve Intensity		
	1.3		Foot Pressure		
	1.4		Thread Tension		
	1.5		Fullness Top/Bottom		
	1.6		Fullness		
	1.7		Foot Stroke Alternation		
	1.8		Backtack At Start		
	1.9		Backtack At End		
	1.10		Thread Trimmer		
	1.11		Size		
	1.12		Seam Graphic		
	1.13		Grading Factor		
1.14	Teach Side (L=1/R=2)				

Menu items					
Menu item	Numerical	Function	Sub-item	Sub-item	Reference
<b>Machine Configuration</b>	2.0	Specify basic machine settings which are applicable to all sewing programs			 p. 98
	2.1		Backtack At Start		
	2.1.1			Number Of Backtack Repetitions	
	2.1.2			Duration Between Backtack Repetitions	
	2.1.3			Number Stitches Backward	
	2.1.4			Number Stitches Forward	
	2.1.5			Speed	
	2.2			Backtack At End	
	2.2.1		Number Of Backtack Repetitions		
	2.2.2		Duration Between Backtack Repetitions		
	2.2.3		Number Stitches Backward		
	2.2.4		Number Stitches Forward		
	2.2.5		Speed		
	2.3		Thread Trimmer		
	2.3.1			Speed	
	2.3.2			Thread Tension	
	2.3.3			Turn Backward After Trimming	
	2.4		Speed		
	2.4.1			Maximum Speed	
	2.4.2			Positioning Speed	
	2.4.3			Softstart Speed	
	2.4.4			Number Stitches Softstart	

Menu items					
Menu item	Numerical	Function	Sub-item	Sub-item	Reference
	2.5		Stop Positions		
	2.5.1			Stop Position After Sewing	
	2.5.2			Stop Position Needle Up	
	2.5.3			Stop Position Needle Down	
	2.6		Foot		
	2.6.1			Foot Lift In Between Seam	
	2.6.2			Foot Lift At Seam End	
	2.6.3			Position Foot Up	
	2.7		Duration Thread Tension After Seam End		
2.8	Other Devices				
<b>User Configuration</b>	3.0	Specify advanced machine settings			 p. 101
	3.1		Signal Sound At Segment Change		
	3.2		Side Switch At Seam End		
	3.3		Abort Program At Pedal -2		
	3.4		Mode Second Pedal		
<b>USB Operations</b>	4.0	Transfer data with a USB key			 p. 102
	4.1		Write Active Sewing Program To USB		
	4.2		Read Sewing Program From USB		
	4.3		Write Global Data Of Control Unit To USB		
	4.4		Overwrite Global Data Of Control Unit With USB Data		



Menu items					
Menu item	Numerical	Function	Sub-item	Sub-item	Reference
<b>Calibration</b>	5.0	Calibration			 p. 103
	5.1		Adjust Flat Sewing Top		
	5.2		Feet Difference Calibration		
	5.3		Thread Tension Calibration		
<b>Reset Operations</b>	6.0	Initialize data			 p. 107
	6.1		Reset All		
	6.2		Reset Sewing Programs		
<b>Input / Output Test</b>	7.0	Quickly check the input and output elements			 p. 108

For all sub-items except for *Size*, an editor will open to set the parameters.

### 15.3 Menu item *Default Program Parameters*

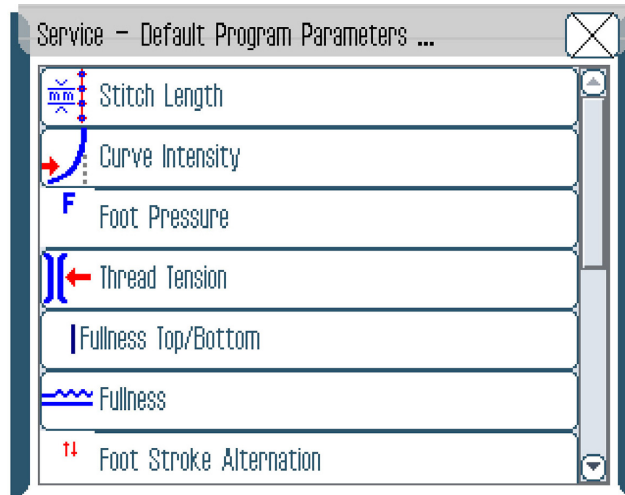
You use the menu item *Default Program Parameters* to define the values that will be preset when a new sewing program is created.



To define the preset values:

1. Select *Default Program Parameters* in the service menu.
- ↳ The following appears on the display:






Fig. 71: Menu item *Default Program Parameters*



2. Press the desired parameter.
3. Enter values that reflect your sewing requirements and can be retained in as many sewing programs as possible in order to make the process of creating new sewing program simple.

#### Parameters in the menu item *Default Program Parameters*

Icon	Entry	Meaning	Possible value range	Preset value
	<b>Stitch Length</b>	Stitch length	1.0 – 4.0	2.5
	<b>Curve Intensity</b>	Curve support	0 – 6	2
	<b>Foot Pressure</b>	Sewing foot pressure	1 – 10	5
	<b>Thread Tension</b>	Thread tension	1 – 99	40
	<b>Fullness Top/Bottom</b>	Fullness Top/Bottom	1 – 2 1 = top 2 = bottom	1
	<b>Fullness</b>	Fullness	0 – 16	0

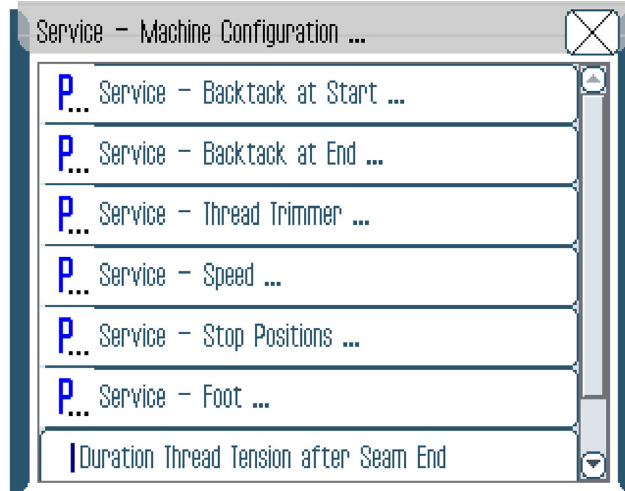
Icon	Entry	Meaning	Possible value range	Preset value
	<b>Foot Stroke Alternation</b>	Alternation: The sewing foot is lifted by this height for each stitch	0 – 2.5	0.0
	<b>Backtack At Start</b>	Start bartack	0 – 1	0
	<b>Backtack At End</b>	End bartack	0 – 1	0
	<b>Thread Trimmer</b>	Thread trimmer	0 = off 1 = on	1
	<b>Size</b>	Sewing material size		Germany, France Men
	<b>Seam Graphic</b>	Symbolic seam graphic for work process	0 – 3	1
	<b>Grading Factor</b>	Grading factor as a percentage, increase from size to size	0.0 – 6.0	2.5
	<b>Teach Side (L=1/R=2)</b>	Sleeve side which is programmed first	2 = R (start with right sleeve) 1 = L (start with left sleeve)	2

## 15.4 Menu item *Machine Configuration*

The menu item *Machine Configuration* allows you to determine the basic settings for the machine which apply to all programs.

*Machine Configuration* has the following sub-items:

Fig. 72: Menu item *Machine Configuration*



The sub-items have further sub-items (📖 p. 92).

### 15.4.1 Sub-items *Backtack At Start/End*

In the *Backtack At Start* and *Backtack At End* sub-items, you can define how the start and end bartack are sewn.

#### Parameters in the *Backtack At Start/End* sub-item

Entry	Meaning	Possible value range	Preset value
<b>Number Of Backtack Repetitions</b>	Number of repetitions per bartack	1 – 10	2
<b>Duration Between Backtack Repetitions</b>	Waiting time when switching between forward and backward stitch	0 – 1000	0
<b>Number Stitches Backward</b>	Number of backward stitches per bartack	1 – 50	3
<b>Number Stitches Forward</b>	Number of forward stitches per bartack	1 – 50	3
<b>Speed</b>	Speed when sewing the bartack	50 – 2000	1000

### 15.4.2 Sub-item *Thread Trimmer*

In the *Thread Trimmer* sub-item, you can define the settings for cutting the thread.

#### Parameters in the *Thread Trimmer* sub-item

Entry	Meaning	Possible value range	Preset value
<b>Speed</b>	Speed when cutting the thread in $\text{min}^{-1}$	50 – 250	180
<b>Thread Tension At Needle</b>	Needle thread tension when cutting the thread in %	1 – 50	10
<b>Turn Backward After Trimming</b>	Automatic reversal after cutting the thread	0 = off 1 = on	1

### 15.4.3 Sub-item *Speed*

In the *Speed* sub-item, you can define the speed in certain situations.

#### Parameters in the *Speed* sub-item

Entry	Meaning	Possible value range	Preset value
<b>Maximum Speed</b>	Maximum speed when fully stepping on the pedal in $\text{min}^{-1}$	500 – 4000	4000
<b>Positioning Speed</b>	Speed when positioning in $\text{min}^{-1}$	10 – 700	400
<b>Softstart Speed</b>	Speed on soft start in $\text{min}^{-1}$	10 – 1000	500
<b>Number Stitches Softstart</b>	Number of soft start stitches	0 – 10	1

#### 15.4.4 Sub-item *Stop Positions*

In the *Stop Positions* sub-item, you can determine the position of the needle when sewing stops.

##### Parameters in the *Stop Positions* sub-item

Entry	Meaning	Possible value range	Preset value
<b>Stop Position After Sewing</b>	Handwheel position after sewing (needle raised) in °	0 – 359	35
<b>Stop Position Needle Up</b>	Handwheel position in the needle's upper idle position when sewing stops in °	0 – 359	0
<b>Stop Position Needle Down</b>	Handwheel position in the needle's lower idle position when sewing stops in °	0 – 359	130

#### 15.4.5 Sub-item *Foot*

##### Parameters in the *Foot* sub-item

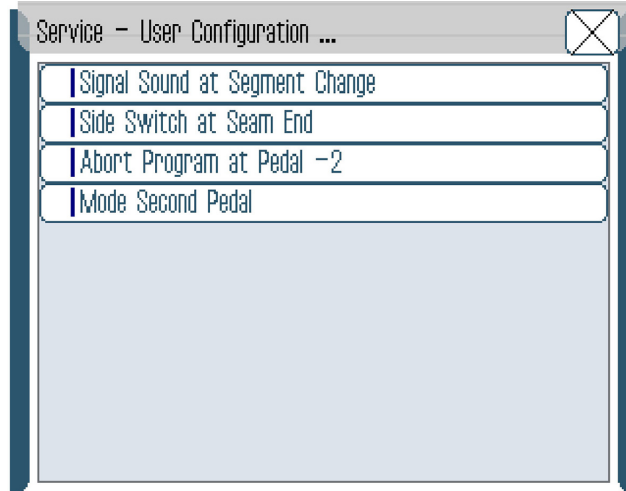
Entry	Meaning	Possible value range	Preset value
<b>Foot Lift In Between Seam</b>	Sewing foot lift in the seam	0 = off 1 = on	35
<b>Foot Lift At Seam End</b>	Sewing foot lift at the seam end (after cutting the thread)	0 = off 1 = on	0
<b>Position Foot Up</b>	Sewing foot position when raised	5 – 14	12

### 15.5 Menu item *User configuration*

The menu item *User Configuration* allows you to define additional machine settings.

*User Configuration* has the following sub-items:

Fig. 73: Menu item *User configuration*



#### Parameters in the menu item *User Configuration*

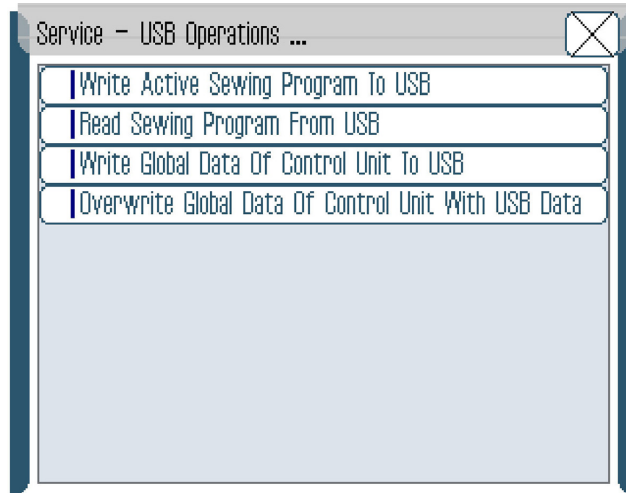
Entry	Meaning	Possible value range	Preset value
<b>Signal Sound At Segment Change</b>	Signal tone when transitioning between program steps	0 = off 1 = on	1
<b>Side Switch At Seam End</b>	Automatic change of side between right/left at seam end	0 = off 1 = on	1
<b>Abort Program At Pedal -2</b>	Program termination with main pedal	0 = off 1 = on	1
<b>Mode Second Pedal</b>	Function of the optional additional pedal	0 = Additional pedal without function 1 = Modification of fullness 2 = Modification of curve support 6 = Fullness -2 – 7 7 = Fullness -2 – 16	1

### 15.6 Menu item *USB Operations*

The menu item *USB Operations* allows you to save or load sewing data to or from a USB key.

*USB Operations* has the following sub-items:

Fig. 74: Menu item *USB Operations*



#### Parameters in the menu item *USB operations*

Entry	Meaning
<b>Write Active Sewing Program To USB</b>	Save active sewing program on the USB key
<b>Read Sewing Program From USB</b>	Load sewing program from USB key
<b>Write Global Data Of Control Unit To USB</b>	Transfer all files to a USB key
<b>Overwrite Global Data Of Control Unit With USB Data</b>	Transfer all data from USB key

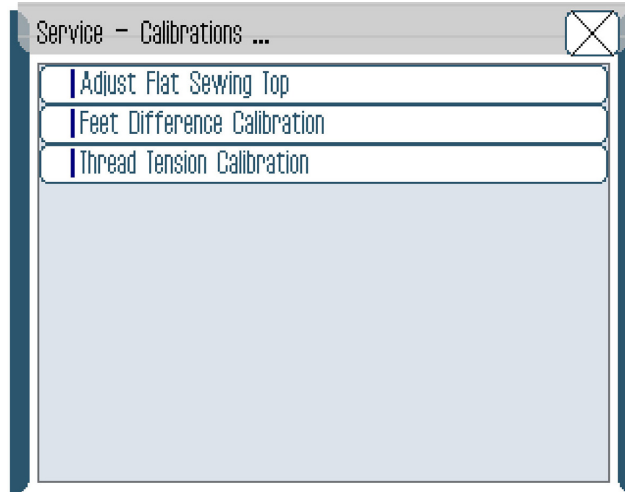


## 15.7 Menu item *Calibration*

In the *Calibration* menu item, you can calibrate the machine.

*Calibration* has the following sub-items:

Fig. 75: Menu item *Calibration*




### Parameters in the menu item *Calibration*

Entry	Meaning
<b>Adjust Flat Sewing Top</b>	Correction of differential top feed in %
<b>Feet Difference Calibration</b>	Calibrate values for the sewing feet
<b>Thread Tension Calibration</b>	Calibrate electrical thread tension

#### 15.7.1 Sub-item *Adjust Flat Sewing Top*

The *Adjust Flat Sewing Top* sub-item allows you to correct the differential top feed as a percentage (-50 – +50).

Correction is required after you have changed the conveyor belts ( p. 39).



Correct the differential top feed as follows:

1. Change values for the differential top feed with +/-1 or +/-10.
2. Change to manual mode MAN.
3. Set fullness = 0 and stitch length = 2.
4. Allow 2 PTFE strips to run through with the fabric side outwards.  
The strips should be fed without offset.

If the strips are not fed without offset, readjust the differential top feed.

### 15.7.2 Sub-item Feet Difference Calibration

In the *Feet Difference Calibration* sub-item, the values for the sewing feet are automatically calibrated.

### 15.7.3 Sub-item Thread Tension Calibration

In the *Thread Tension Calibration* sub-item, you can calibrate the electronic needle thread tension.

Prerequisite: An external thread tension measurement device is available, and the calibration is performed with a thread with a thickness of 120.



#### Important

The thread tension has been set at the factory both mechanically and electronically.

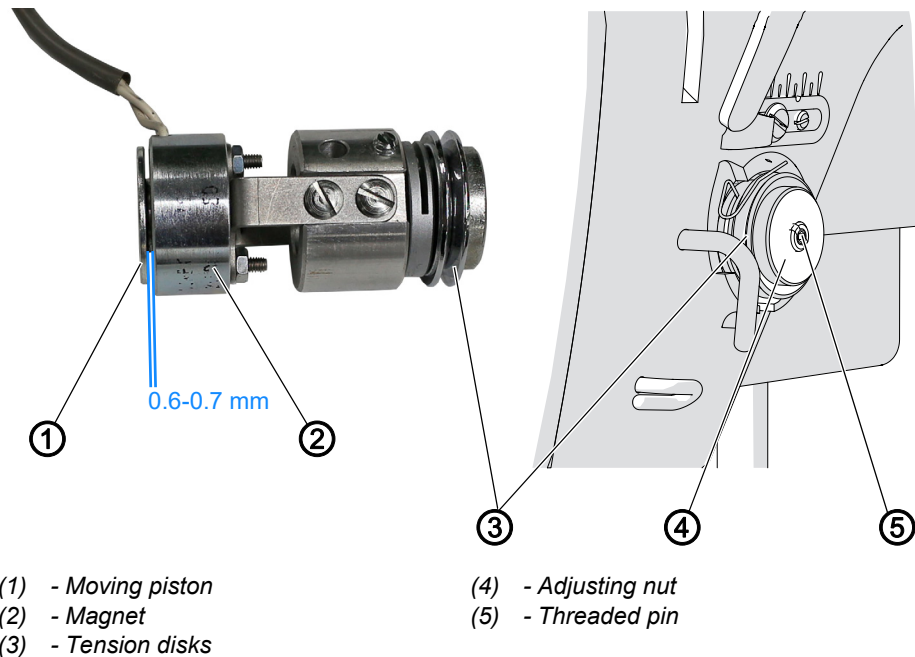
After a complete reset or installing new software, the calibration values remain the same.

After a change of the control, the calibration values ONLY have to be entered again if the existing machine ID will NO longer be used.

After a change of the control, you should check if the calibration values have been stored correctly in the control. You can find the correct values on the sticker located on the underside of the base plate. You will be able to see the sticker after tilting the machine head (📖 p. 15).

If it needs to be disassembled, the electronic thread tension must be calibrated again after its reassembly (📖 p. 56) - first mechanically and then electronically.

Fig. 76: Sub-item Thread Tension Calibration (1)





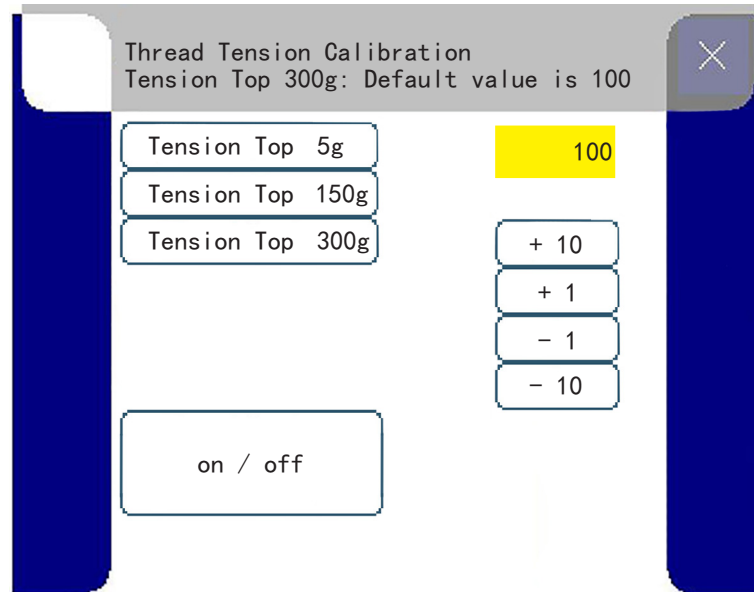
To calibrate the electronic thread tension **mechanically**:

1. Loosen the threaded pin (5).
2. Turn the adjusting nut (4).
- ↳ The gap between the moving piston (1) and the magnet (2) must be 0.6 to 0.7 mm.



3. Open the menu *Service > Calibration* and select the *Thread Tension Calibration* sub-item

Fig. 77: Sub-item *Thread Tension Calibration* (2)



### Order

Set the following 3 calibration positions one after the other for the needle thread:

- **Position 3** – maximum tension (300 g)
- **Position 2** – medium tension (150 g)
- **Position 1** – minimum tension (5 g)

### Calibration steps



To set **calibration position 3**:

1. Insert the thread and guide it up to the thread lever.
2. After the thread lever, feed the thread into the thread tension measurement device.
3. Select *Tension Top 300g*.
4. Press *On/Off*.
- ↳ The tension element is closed.
5. Measure the tension value. It must be at 300 g.



If it is not at 300 g, correct as follows:



6. Loosen the threaded pin (3).



7. Press *On/Off*.

↳ The tension element opens.



8. Very gently turn the adjusting nut (1):

- **Reduce the value:** turn clockwise
- **Increase the value:** turn counterclockwise



9. Select *Tension Top 300g* again.

10. Press *On/Off* and measure the tension value.



11. At the point at which the thread tension measurement device displays a value of 300 g:

Tighten the threaded pin (3) without changing the position of the adjusting nut (1).



12. Press *On/Off*.

↳ The tension element opens.



To set **calibration position 2:**

1. Select *Tension Top 150g*.
2. Change the thread tension with +/-1 or +/-10 until the thread tension measurement device displays 150 g.
3. Exit the menu item.



To set **calibration position 1:**

1. Select *Tension Top 5g*.
2. Change the thread tension with +/-1 or +/-10 until the thread tension measurement device displays a value.
3. Exit the menu item.

## 15.8 Menu item *Reset Operations*

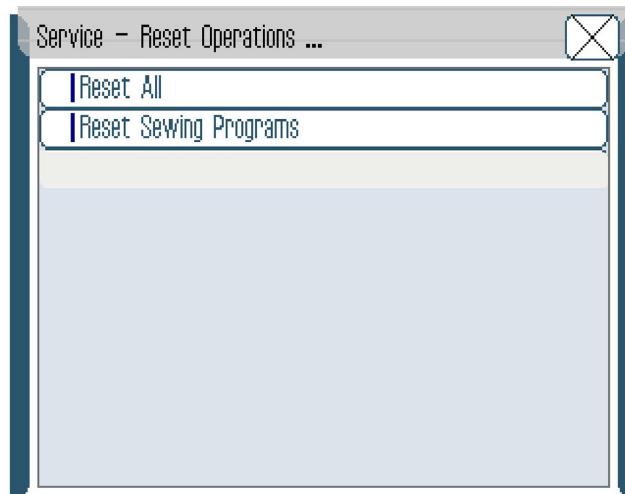
The menu item *Reset Operations* allows you to initialize sewing programs and parameters to the delivery state. To do this, re-entering the code is requested (for reasons of security).



To select the menu item:

1. Select *Reset Operations* in the service menu.
- ↳ The input mask for the code appears on the display.
2. Enter the code 25483 using the keypad.
- ↳ *Reset Operations* has the following sub-items:

Fig. 78: Menu item *Reset Operations*



### Parameters in the menu item *Reset Operations*

Entry	Meaning
<b>Reset All</b>	Initialize to factory defaults
<b>Reset Sewing Programs</b>	Initialize sewing programs

#### 15.8.1 Sub-item *Reset All*

In the *Reset All* sub-item, you can reset all sewing programs and parameters to the delivery state.

Only the calibration values for the thread tension and sewing feet are retained.



To reset all sewing programs and parameters:

1. Press *Reset All*.
- ↳ All sewing programs and parameters (except for the calibration values for the thread tension and sewing feet) will be reset to their delivery state.

### 15.8.2 Sub-item *Reset Sewing Programs*

In the *Reset Sewing Programs* sub-item, you can delete all the sewing programs you have created yourself.

Only the standard programs are retained and are returned to their delivery state.



To delete all the sewing programs you have created yourself:

1. Press *Reset Sewing Programs*.

↳ All the sewing programs you have created yourself will be deleted.  
The standard programs will be returned to their delivery state.

### 15.9 Menu item *Test Input / Output*

In the menu item *Test Input / Output*, you can test whether certain elements are functioning.

#### WARNING



**Risk of injury from moving, cutting and sharp parts!**

Crushing, cutting and punctures are possible.

Exercise the utmost caution when performing tests when the machine is running.

## 15.10 Performing a software update

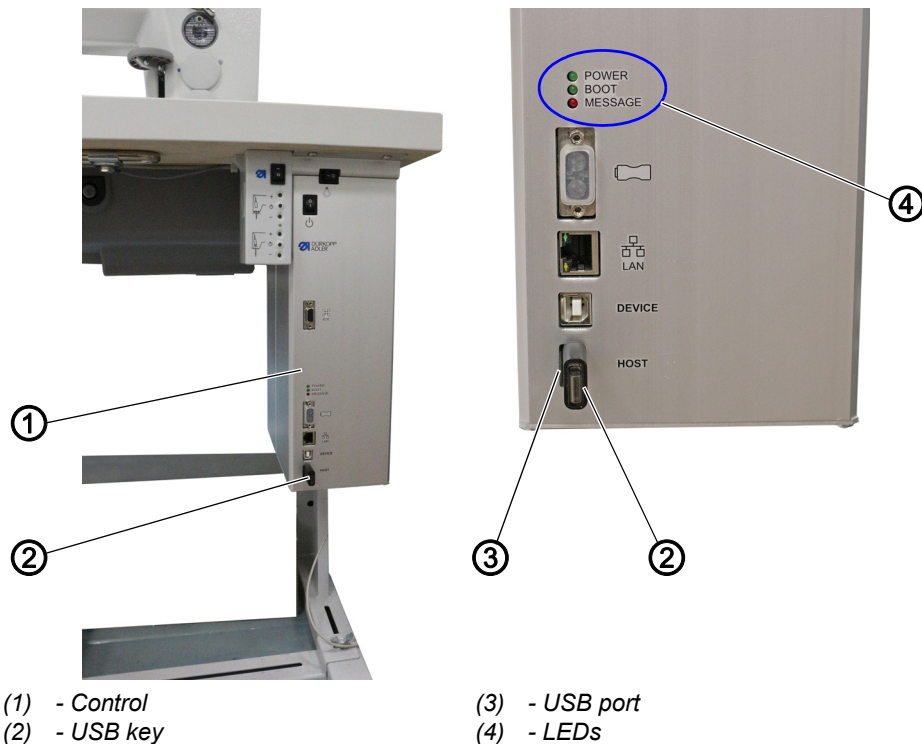


### Information

Machines with software versions up to and including A.3.27 require that you perform a comprehensive, one-time update (bootloader update). Machines with software versions A.3.29 do not require a bootloader update and can be updated immediately.

1. Download the bootloader software from Duerkopp Adler's website (<https://software.duerkopp-adler.com/maschinenprogramme.html>).
2. Unzip the file to a USB key.
  - ↳ This creates 2 folders: *bootscr* and *update*.
3. Plug the USB key (2) into the USB port (3) on the control (1).
4. Switch on the machine.
  - ↳ The update is launched. The LEDs (4) illuminate.
  - ↳ The update is complete when only the POWER LED is lit.

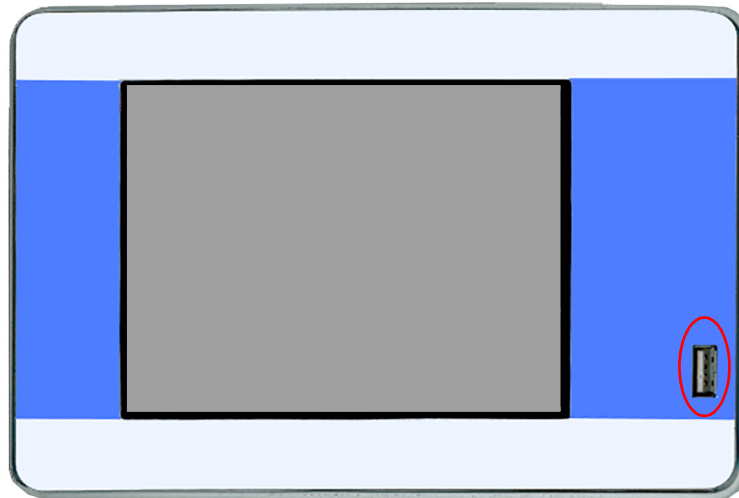
Fig. 79: Performing a software update (1)



To perform the software update:

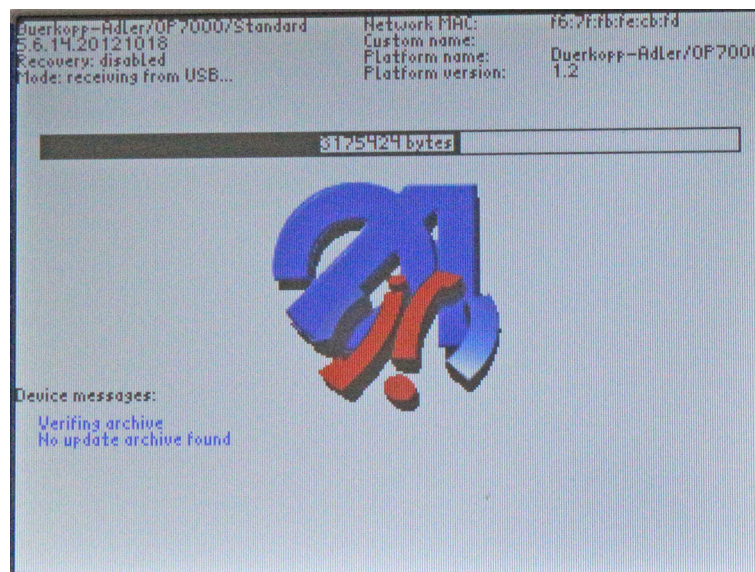
1. Download the update file from Dürkopp Adler's website. The file is named, for example:  
**9899\_65500\_700\_A03.61\_2016-08-15.jcbi**
2. Copy the update file to a blank Dürkopp Adler USB key (part number 9835 301003).

Fig. 80: Performing a software update (2)



3. Switch off the machine and wait for approx. 15 seconds.
  4. Connect the Dürkopp Adler USB key to the OP7000.
  5. Restart the machine.
- ↪ The OP7000 detects the USB key and updates the control panel software.

Fig. 81: Performing a software update (3)



- ↪ The update will take approx. 2 minutes.



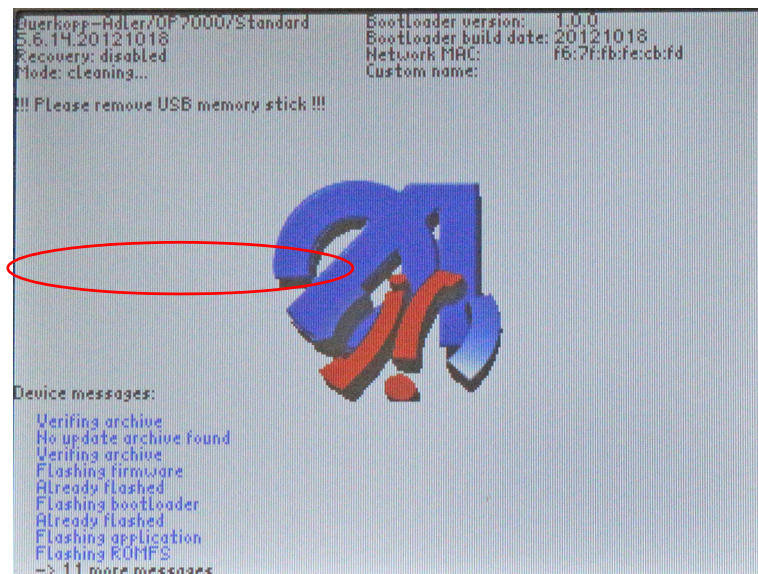
**Important**

Do not switch off the machine while the update is in progress!

- ↪ Remove the USB key when prompted to do so:

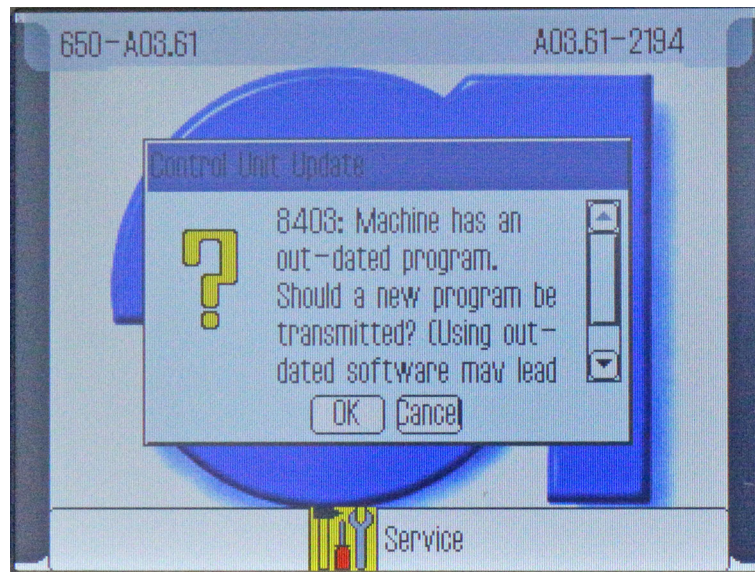


Fig. 82: Performing a software update (4)



- ↪ The machine restarts automatically.  
The display shows notice 8403: *Machine has an outdated program. Should a new program be transmitted?*

Fig. 83: Performing a software update (5)




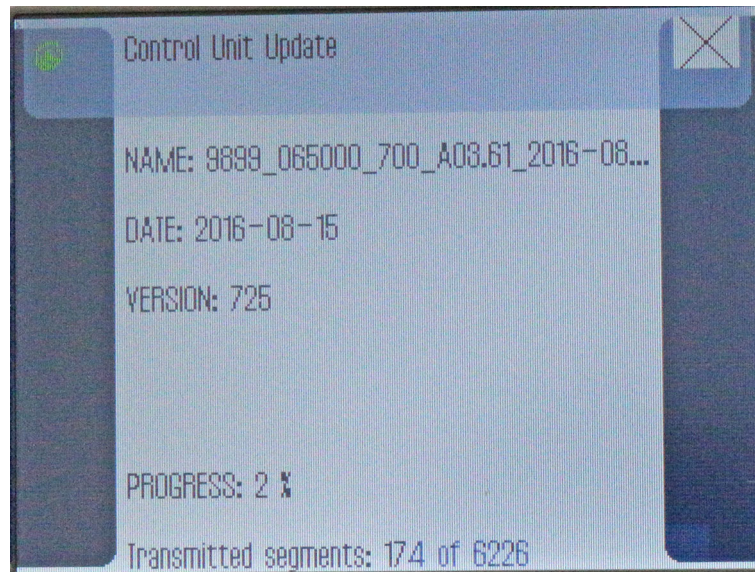
-  6. Confirm with **OK**.
- ↪ The update is carried out.

Fig. 84: Performing a software update (6)

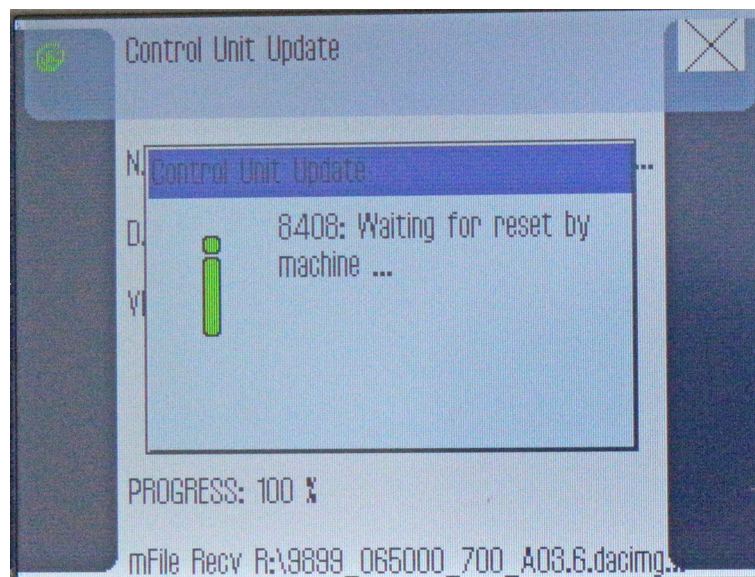


**Important**

Do not switch off the machine while the update is in progress!

↪ The display shows notice 8408: *Waiting for Reset by machine ...*

Fig. 85: Performing a software update (7)




↪ The machine restarts automatically.  
After restarting, the machine loads the start screen.



**Information**

If the machine does not restart automatically, you must activate the restart using the service menu

**Important**

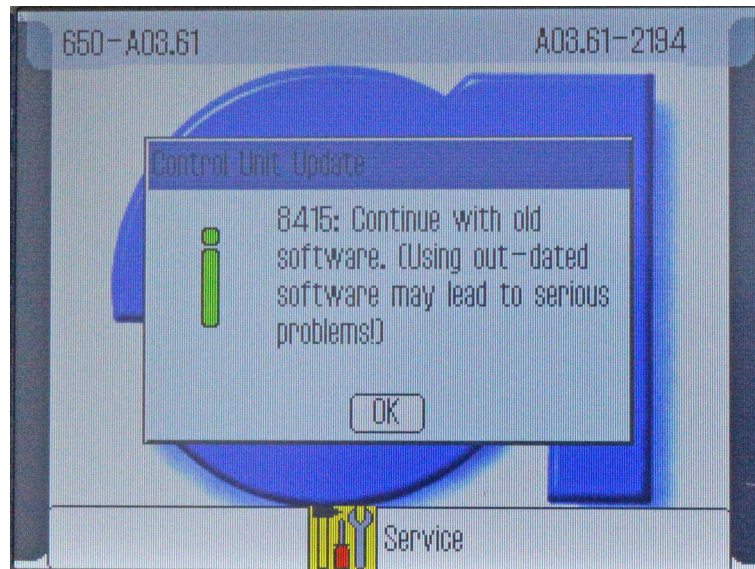
7. Calibrate the electronic thread tension ( p. 104).

**OR**

8. Press **CANCEL** to cancel the update.

↪ The following warning appears:

Fig. 86: Performing a software update (8)



↪ After confirming with **OK**, you can continue working with the old control software.

**Important**

Working with an outdated software can result in serious problems, as the control software does not match the operating software.



## 16 Maintenance

### WARNING



#### Risk of injury from sharp parts!

Punctures and cutting possible.

Prior to any maintenance work, switch off the machine or set the machine to threading mode.

### WARNING



#### Risk of injury from moving parts!

Crushing possible.

Prior to any maintenance work, switch off the machine or set the machine to threading mode.

This chapter describes maintenance work that needs to be carried out on a regular basis to extend the service life of the machine and achieve the desired seam quality.

This chapter describes maintenance work that needs to be carried out on a regular basis to extend the service life of the machine and achieve the desired seam quality.

### Maintenance intervals

Work to be carried out	Operating hours			
	8	40	160	500
<b>Machine head</b>				
Removing lint and thread remnants	●			
Cleaning the motor fan mesh	●			
Check the upper and lower conveyor belts for wear		●		
Check sewing foot for wear		●		
Lubricate the joints on the gear				●
Lubricating the needle bar				●

## 16.1 Cleaning

### WARNING



#### **Risk of injury from flying particles!**

Flying particles can enter the eyes, causing injury.

Wear safety goggles.

Hold the compressed air gun so that the particles do not fly close to people.

Make sure no particles fly into the oil pan.

### NOTICE

#### **Property damage from soiling!**

Lint and thread remnants can impair the operation of the machine.

Clean the machine as described.

### NOTICE

#### **Property damage from solvent-based cleaners!**

Solvent-based cleaners will damage paintwork.

Use only solvent-free substances for cleaning.

The following areas must be cleaned with a compressed air pistol or a brush:

- Throat plate
- Hook
- Bobbin case and interior
- Thread trimmer
- Needle
- Engine fan filter
- Conveyor belts
- Sewing foot
- Belt tensioner



To clean the machine:

1. Remove any lint and thread remnants using a compressed air gun or a brush.

## 16.2 Lubricating

### CAUTION



#### Risk of injury from contact with oil!

Oil can cause a rash if it comes into contact with skin.

Avoid skin contact with oil.

If oil has come into contact with your skin, wash the affected areas thoroughly.

### NOTICE

#### Property damage from incorrect oil!

Incorrect oil types can result in damage to the machine.

Only use oil that complies with the data in the instructions.

### CAUTION



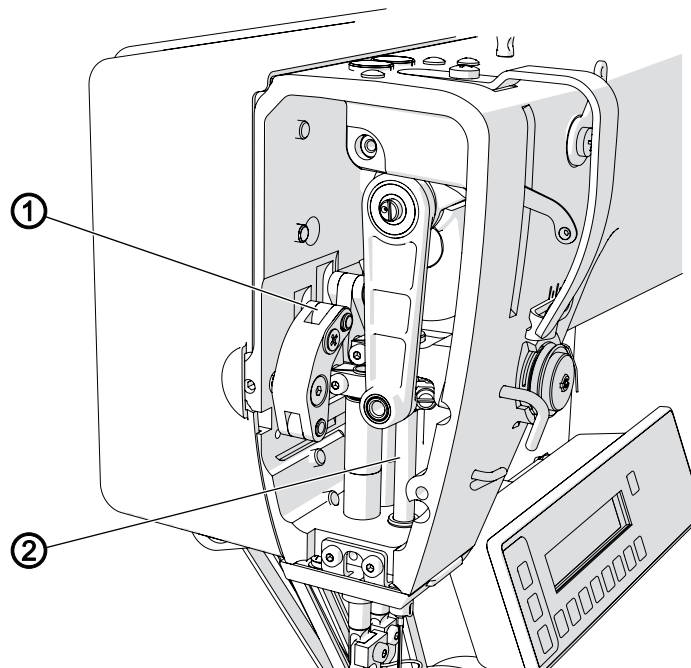
#### Risk of environmental damage from oil!

Oil is a pollutant and must not enter the sewage system or the soil.

Carefully collect up used oil.

Dispose of used oil and oily machine parts in accordance with national regulations.

Fig. 87: Lubricating



(1) - Joints on the gear

(2) - Needle bar



Lubricate the machine as follows:

1. Lubricate the following areas on the machine head with lubricating grease:
  - Joints on the gear
  - Needle bar

### **16.3 Parts list**

A parts list can be ordered from Dürkopp Adler. Or visit our website for further information at:

[www.duerkopp-adler.com](http://www.duerkopp-adler.com)





## 17 Decommissioning

### WARNING



#### **Risk of injury from a lack of care!**

Serious injuries may occur.

ONLY clean the machine when it is switched off.  
Allow ONLY trained personnel to disconnect  
the machine.

### CAUTION



#### **Risk of injury from contact with oil!**

Oil can cause a rash if it comes into contact with  
skin.

Avoid skin contact with oil.  
If oil has come into contact with your skin, wash  
the affected areas thoroughly.



To decommission the machine:

1. Switch off the machine.
2. Unplug the power plug.
3. If applicable, disconnect the machine from the compressed air supply.
4. Remove residual oil from the oil pan using a cloth.
5. Cover the control panel to protect it from soiling.
6. Cover the control to protect it from soiling.
7. Cover the entire machine if possible to protect it from contamination and damage.



## 18 Disposal

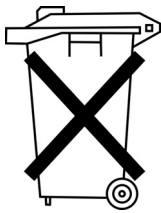
### CAUTION



#### **Risk of environmental damage from improper disposal!**

Improper disposal of the machine can result in serious environmental damage.

**ALWAYS** comply with the national regulations regarding disposal.



The machine must not be disposed of in the normal household waste.

The machine must be disposed of in a suitable manner in accordance with all applicable national regulations.

When disposing of the machine, be aware that it consists of a range of different materials (steel, plastic, electronic components, etc.). Follow the national regulations when disposing these materials.



## 19 Troubleshooting

### 19.1 Customer Service

Contact for repairs and issues with the machine:

#### **Dürkopp Adler GmbH**

Potsdamer Str. 190  
33719 Bielefeld, Germany

Tel. +49 (0) 180 5 383 756

Fax +49 (0) 521 925 2594

Email: [service@duerkopp-adler.com](mailto:service@duerkopp-adler.com)

Internet: [www.duerkopp-adler.com](http://www.duerkopp-adler.com)



## 19.2 Messages of the software

Please contact customer service if an error occurs that is not described here. Do not attempt to correct the error yourself.

**Table of software messages**

Code	Type	Possible causes	Remedial action
1000	Error	Sewing motor error: <ul style="list-style-type: none"> <li>Encoder plug (Sub-D, 9-pin) not connected or defective</li> <li>Encoder defective</li> </ul>	<ul style="list-style-type: none"> <li>Check the connection of the encoder cable and replace, if necessary</li> </ul>
1001	Error	Sewing motor error: <ul style="list-style-type: none"> <li>Sewing motor plug not connected or defective</li> </ul>	<ul style="list-style-type: none"> <li>Check the connection of the sewing motor cable</li> <li>Test sewing motor phases (R = 2.8Ω, high impedance to PE)</li> <li>Replace encoder</li> <li>Replace sewing motor</li> <li>Replace control</li> </ul>
1002	Error	Sewing motor insulation fault	<ul style="list-style-type: none"> <li>Check motor phase and PE for low-impedance connection</li> <li>Replace encoder</li> <li>Replace sewing motor</li> </ul>
1004	Error	Sewing motor error: <ul style="list-style-type: none"> <li>Incorrect direction of rotation</li> </ul>	<ul style="list-style-type: none"> <li>Replace encoder</li> <li>Check plug assignment and change, if necessary</li> <li>Check wiring in machine distributor and change it, if necessary</li> <li>Test motor phases and check for correct value</li> </ul>
1005	Error	Sewing motor current error: <ul style="list-style-type: none"> <li>Sewing motor blocked</li> <li>Encoder cable not connected or defective</li> <li>Encoder defective</li> </ul>	<ul style="list-style-type: none"> <li>Remove blockage</li> <li>Check the encoder cable and replace, if necessary</li> <li>Replace sewing motor</li> </ul>
1006	Error	Sewing motor error: <ul style="list-style-type: none"> <li>Max. speed exceeded</li> <li>Sewing motor cable defective</li> <li>Sewing motor defective</li> </ul>	<ul style="list-style-type: none"> <li>Switch off and on the machine</li> <li>Replace encoder</li> <li>Perform reset</li> <li>Replace sewing motor</li> <li>Contact customer service</li> </ul>
1007	Error	Error in the reference run	<ul style="list-style-type: none"> <li>Replace encoder</li> <li>Check for stiff movement</li> </ul>
1008	Error	Fault in sewing motor encoder	<ul style="list-style-type: none"> <li>Replace encoder</li> </ul>

Code	Type	Possible causes	Remedial action
1010	Error	Sewing motor synchronization error: <ul style="list-style-type: none"> <li>External synchronizer plug (Sub-D, 9-pin) not connected</li> </ul>	<ul style="list-style-type: none"> <li>Connect plug of external synchronizer to control, use correct connection (Sync)</li> <li>Replace the reference switch or synchronizer</li> <li>Only required for machines with transmission!</li> </ul>
1011	Error	Sewing motor synchronization error (Z pulse)	<ul style="list-style-type: none"> <li>Switch off the control, use handwheel to turn and switch on the control again</li> <li>If error is not corrected, check encoder</li> </ul>
1012	Error	Sewing motor synchronization error	<ul style="list-style-type: none"> <li>Replace synchronizer</li> </ul>
1051	Error	Sewing motor timeout: <ul style="list-style-type: none"> <li>Cable to sewing motor</li> <li>Reference switch defective</li> <li>Reference switch defective</li> </ul>	<ul style="list-style-type: none"> <li>Replace cable</li> <li>Replace reference switch</li> </ul>
1052	Error	Sewing motor overcurrent: <ul style="list-style-type: none"> <li>Sewing motor cable defective</li> <li>Sewing motor defective</li> <li>Control defective</li> </ul>	<ul style="list-style-type: none"> <li>Replace sewing motor cable</li> <li>Replace sewing motor</li> <li>Replace control</li> </ul>
1053	Error	Sewing motor overvoltage	<ul style="list-style-type: none"> <li>Check mains voltage</li> </ul>
1054	Error	Internal short circuit	<ul style="list-style-type: none"> <li>Replace control</li> </ul>
1055	Error	Sewing motor overload (I <sup>2</sup> T): <ul style="list-style-type: none"> <li>Sewing motor not moving freely or blocked</li> <li>Sewing motor defective</li> <li>Control defective</li> </ul>	<ul style="list-style-type: none"> <li>Remove the cause of the stiff movement or blockage</li> <li>Replace sewing motor</li> <li>Replace control</li> </ul>
1056	Error	Sewing motor overtemperature: <ul style="list-style-type: none"> <li>Sewing motor not moving freely</li> <li>Sewing motor defective</li> <li>Control defective</li> </ul>	<ul style="list-style-type: none"> <li>Eliminate sluggishness</li> <li>Replace sewing motor</li> <li>Replace control</li> </ul>
1058	Error	Sewing motor speed greater than setpoint: <ul style="list-style-type: none"> <li>Reference switch defective</li> <li>Sewing motor defective</li> </ul>	<ul style="list-style-type: none"> <li>Replace reference switch</li> <li>Replace sewing motor</li> </ul>
1060	Error	PowerParts	<ul style="list-style-type: none"> <li>Replace control</li> </ul>
1061	Error	Sewing motor disturbance: <ul style="list-style-type: none"> <li>Encoder defective</li> <li>Sewing motor defective</li> </ul>	<ul style="list-style-type: none"> <li>Switch off and on the machine</li> <li>Replace encoder</li> <li>Replace sewing motor</li> <li>Contact customer service</li> </ul>
1062	Error	Sewing motor disturbance (IDMA auto increment)	<ul style="list-style-type: none"> <li>Switch off and on the machine</li> </ul>
1120	Error	Software error: <ul style="list-style-type: none"> <li>Parameter not initialized</li> </ul>	<ul style="list-style-type: none"> <li>Perform a software update</li> </ul>

Code	Type	Possible causes	Remedial action
1203	Information	Sewing motor: Position not reached	<ul style="list-style-type: none"> <li>• Switch off and on the machine</li> <li>• Perform a software update</li> <li>• Contact customer service</li> </ul>
1302	Error	Sewing motor current error: <ul style="list-style-type: none"> <li>• Sewing motor blocked</li> <li>• Encoder cable not connected or defective</li> <li>• Encoder defective</li> </ul>	<ul style="list-style-type: none"> <li>• Remove blockage</li> <li>• Check the encoder cable and replace, if necessary</li> <li>• Replace sewing motor</li> </ul>
1330	Error	No response from sewing motor	<ul style="list-style-type: none"> <li>• Switch off and on the machine</li> <li>• Perform a software update</li> <li>• Contact customer service</li> </ul>
2102	Error	X-axis stepper motor: <ul style="list-style-type: none"> <li>• Stepper motor not moving freely or blocked</li> <li>• Encoder cable not connected or defective</li> <li>• Stepper motor cable not connected or defective</li> <li>• Encoder defective</li> <li>• Stepper motor faulty</li> </ul>	<ul style="list-style-type: none"> <li>• Remove the cause of the stiff movement or blockage</li> <li>• Check the encoder cable and replace, if necessary</li> <li>• Replace encoder</li> </ul> If the stepper motor is not supplied with current: <ul style="list-style-type: none"> <li>• Check the stepper motor cable and replace, if necessary</li> <li>• Replace stepper motor</li> </ul>
2103	Error	X-axis stepper motor step losses: <ul style="list-style-type: none"> <li>• Stiff mechanical movement or blockage</li> </ul>	<ul style="list-style-type: none"> <li>• Remove the cause of the stiff mechanical movement or blockage</li> </ul>
2121	Error	X-axis stepper motor: <ul style="list-style-type: none"> <li>• Encoder plug (Sub-D, 9-pin) not connected or defective</li> <li>• Encoder defective</li> </ul>	<ul style="list-style-type: none"> <li>• Check the connection of the encoder cable and replace, if necessary</li> </ul>
2122	Information	Pulse wheel search time out	<ul style="list-style-type: none"> <li>• Check connection cables</li> <li>• Check stepper motor for stiff movement</li> </ul>
2130	Error	X-axis stepper motor not responding	<ul style="list-style-type: none"> <li>• Perform a software update</li> <li>• Replace control</li> </ul>
2152	Error	X-axis stepper motor overcurrent	<ul style="list-style-type: none"> <li>• Replace stepper motor</li> </ul>
2153	Error	Overvoltage	<ul style="list-style-type: none"> <li>• Check mains voltage</li> </ul>
2155	Error	X-axis stepper motor overload ( $I^2T$ ): <ul style="list-style-type: none"> <li>• Stepper motor not moving freely or blocked</li> <li>• Stepper motor faulty</li> <li>• Control defective</li> </ul>	<ul style="list-style-type: none"> <li>• Remove the blockage or the cause of the stiff movement</li> <li>• Replace stepper motor</li> <li>• Replace control</li> </ul>
2156	Error	X-axis stepper motor: <ul style="list-style-type: none"> <li>• Stepper motor sluggish</li> <li>• Stepper motor faulty</li> <li>• Control defective</li> </ul>	<ul style="list-style-type: none"> <li>• Eliminate sluggishness</li> <li>• Replace stepper motor</li> <li>• Replace control</li> </ul>
2162	Error	X-axis stepper motor disturbance (IDMA auto increment)	<ul style="list-style-type: none"> <li>• Switch off and on the machine</li> </ul>



Code	Type	Possible causes	Remedial action
2171	Error	Watchdog	<ul style="list-style-type: none"> <li>• Switch off and on the machine</li> <li>• Perform a software update</li> <li>• Contact customer service</li> </ul>
2172	Error	Stepper motor overvoltage: <ul style="list-style-type: none"> <li>• Stepper motor card defective</li> </ul>	<ul style="list-style-type: none"> <li>• Replace control</li> </ul>
2173	Error	X-axis stepper motor error	<ul style="list-style-type: none"> <li>• Check the connection</li> <li>• Test stepper motor phases (R = 2.8Ω, high impedance to PE)</li> <li>• Replace encoder</li> <li>• Replace stepper motor</li> <li>• Replace control</li> </ul>
2174	Error	Software error	<ul style="list-style-type: none"> <li>• Perform reset</li> <li>• Perform a software update</li> <li>• Contact customer service</li> </ul>
2175	Error	Magnet wheel search	<ul style="list-style-type: none"> <li>• Check the connection</li> <li>• Test stepper motor phases (R = 2.8Ω, high impedance to PE)</li> <li>• Replace encoder</li> <li>• Replace stepper motor</li> <li>• Replace control</li> </ul>
2177	Error	Stepper motor overload (I <sup>2</sup> T)	<ul style="list-style-type: none"> <li>• Remove the cause of the stiff movement or blockage</li> <li>• Replace stepper motor</li> <li>• Replace control</li> </ul>
2178	Error	Encoder error	<ul style="list-style-type: none"> <li>• Check the connection of the encoder cable and replace, if necessary</li> <li>• Replace control</li> </ul>
2179	Error	Current sensor: <ul style="list-style-type: none"> <li>• Stepper motor card defective</li> <li>• Control defective</li> </ul>	<ul style="list-style-type: none"> <li>• Replace control</li> </ul>
2180	Error	Direction	<ul style="list-style-type: none"> <li>• Replace encoder</li> <li>• Check plug assignment and change, if necessary</li> <li>• Check wiring in machine distributor and change it, if necessary</li> <li>• Test stepper motor phases and check for correct value</li> </ul>
2181	Error	Error in the reference run	<ul style="list-style-type: none"> <li>• Replace reference switch</li> </ul>
2182	Error	Stepper motor current error	<ul style="list-style-type: none"> <li>• Remove blockage</li> <li>• Check the encoder cable and replace, if necessary</li> <li>• Replace stepper motor</li> </ul>
2183	Error	Stepper motor overcurrent	<ul style="list-style-type: none"> <li>• Replace sewing motor cable</li> <li>• Replace stepper motor</li> <li>• Replace control</li> </ul>
2184	Error	Software error	<ul style="list-style-type: none"> <li>• Perform reset</li> <li>• Perform a software update</li> <li>• Contact customer service</li> </ul>

Code	Type	Possible causes	Remedial action
2185	Error	Stepper motor insulation error	<ul style="list-style-type: none"> <li>• Check motor phase and PE for low-impedance connection</li> <li>• Replace encoder</li> <li>• Replace stepper motor</li> </ul>
2186	Error	Software error	<ul style="list-style-type: none"> <li>• Perform reset</li> <li>• Perform a software update</li> <li>• Contact customer service</li> </ul>
2187	Error	Software error	<ul style="list-style-type: none"> <li>• Perform reset</li> <li>• Perform a software update</li> <li>• Contact customer service</li> </ul>
2188	Error	Software error	<ul style="list-style-type: none"> <li>• Perform reset</li> <li>• Perform a software update</li> <li>• Contact customer service</li> </ul>
2202	Error	Y-axis stepper motor: <ul style="list-style-type: none"> <li>• Stepper motor not moving freely or blocked</li> <li>• Encoder cable not connected or defective</li> <li>• Stepper motor cable not connected or defective</li> <li>• Encoder defective</li> <li>• Stepper motor faulty</li> </ul>	<ul style="list-style-type: none"> <li>• Remove the cause of the stiff movement or blockage</li> <li>• Check the encoder cable and replace, if necessary</li> <li>• Replace encoder</li> </ul> If the stepper motor is not supplied with current: <ul style="list-style-type: none"> <li>• Check the stepper motor cable and replace, if necessary</li> <li>• Replace stepper motor</li> </ul>
2203	Error	Y-axis stepper motor step losses: <ul style="list-style-type: none"> <li>• Stiff mechanical movement or blockage</li> </ul>	<ul style="list-style-type: none"> <li>• Remove the cause of the stiff mechanical movement or blockage</li> </ul>
2221	Error	Y-axis stepper motor: <ul style="list-style-type: none"> <li>• Encoder plug (Sub-D, 9-pin) not connected or defective</li> <li>• Encoder defective</li> </ul>	<ul style="list-style-type: none"> <li>• Check the connection of the encoder cable and replace, if necessary</li> </ul>
2222	Information	Pulse wheel search time out	<ul style="list-style-type: none"> <li>• Check connection cables</li> <li>• Check stepper motor for stiff movement</li> </ul>
2230	Error	Y-axis stepper motor not responding	<ul style="list-style-type: none"> <li>• Perform a software update</li> <li>• Replace control</li> </ul>
2252	Error	Y-axis stepper motor overcurrent	<ul style="list-style-type: none"> <li>• Replace stepper motor</li> </ul>
2253	Error	Overvoltage	<ul style="list-style-type: none"> <li>• Check mains voltage</li> </ul>
2255	Error	Y-axis stepper motor overload ( $I^2T$ ): <ul style="list-style-type: none"> <li>• Stepper motor not moving freely or blocked</li> <li>• Stepper motor faulty</li> <li>• Control defective</li> </ul>	<ul style="list-style-type: none"> <li>• Remove the blockage or the cause of the stiff movement</li> <li>• Replace stepper motor</li> <li>• Replace control</li> </ul>
2256	Error	Y-axis stepper motor: <ul style="list-style-type: none"> <li>• Stepper motor sluggish</li> <li>• Stepper motor faulty</li> <li>• Control defective</li> </ul>	<ul style="list-style-type: none"> <li>• Eliminate sluggishness</li> <li>• Replace stepper motor</li> <li>• Replace control</li> </ul>

Code	Type	Possible causes	Remedial action
2262	Error	Y-axis stepper motor disturbance (IDMA auto increment)	<ul style="list-style-type: none"> <li>• Switch off and on the machine</li> </ul>
2271	Error	Watchdog	<ul style="list-style-type: none"> <li>• Switch off and on the machine</li> <li>• Perform a software update</li> <li>• Contact customer service</li> </ul>
2272	Error	Stepper motor overvoltage: <ul style="list-style-type: none"> <li>• Stepper motor card defective</li> </ul>	<ul style="list-style-type: none"> <li>• Replace control</li> </ul>
2273	Error	Y-axis stepper motor error	<ul style="list-style-type: none"> <li>• Check the connection</li> <li>• Test stepper motor phases (R = 2.8Ω, high impedance to PE)</li> <li>• Replace encoder</li> <li>• Replace stepper motor</li> <li>• Replace control</li> </ul>
2274	Error	Software error	<ul style="list-style-type: none"> <li>• Perform reset</li> <li>• Perform a software update</li> <li>• Contact customer service</li> </ul>
2275	Error	Magnet wheel search	<ul style="list-style-type: none"> <li>• Check the connection</li> <li>• Test stepper motor phases (R = 2.8Ω, high impedance to PE)</li> <li>• Replace encoder</li> <li>• Replace stepper motor</li> <li>• Replace control</li> </ul>
2277	Error	Stepper motor overload (I <sup>2</sup> T)	<ul style="list-style-type: none"> <li>• Remove the cause of the stiff movement or blockage</li> <li>• Replace stepper motor</li> <li>• Replace control</li> </ul>
2278	Error	Encoder error	<ul style="list-style-type: none"> <li>• Check the connection of the encoder cable and replace, if necessary</li> <li>• Replace control</li> </ul>
2279	Error	Current sensor: <ul style="list-style-type: none"> <li>• Stepper motor card defective</li> <li>• Control defective</li> </ul>	<ul style="list-style-type: none"> <li>• Replace control</li> </ul>
2280	Error	Direction	<ul style="list-style-type: none"> <li>• Replace encoder</li> <li>• Check plug assignment and change, if necessary</li> <li>• Check wiring in machine distributor and change it, if necessary</li> <li>• Test stepper motor phases and check for correct value</li> </ul>
2281	Error	Error in the reference run	<ul style="list-style-type: none"> <li>• Replace reference switch</li> </ul>
2282	Error	Stepper motor current error	<ul style="list-style-type: none"> <li>• Remove blockage</li> <li>• Check the encoder cable and replace, if necessary</li> <li>• Replace stepper motor</li> </ul>
2283	Error	Stepper motor overcurrent	<ul style="list-style-type: none"> <li>• Replace sewing motor cable</li> <li>• Replace stepper motor</li> <li>• Replace control</li> </ul>

Code	Type	Possible causes	Remedial action
2284	Error	Software error	<ul style="list-style-type: none"> <li>• Perform reset</li> <li>• Perform a software update</li> <li>• Contact customer service</li> </ul>
2285	Error	Stepper motor insulation error	<ul style="list-style-type: none"> <li>• Check motor phase and PE for low-impedance connection</li> <li>• Replace encoder</li> <li>• Replace stepper motor</li> </ul>
2286	Error	Software error	<ul style="list-style-type: none"> <li>• Perform reset</li> <li>• Perform a software update</li> <li>• Contact customer service</li> </ul>
2287	Error	Software error	<ul style="list-style-type: none"> <li>• Perform reset</li> <li>• Perform a software update</li> <li>• Contact customer service</li> </ul>
2288	Error	Software error	<ul style="list-style-type: none"> <li>• Perform reset</li> <li>• Perform a software update</li> <li>• Contact customer service</li> </ul>
2302	Error	Z-axis stepper motor: <ul style="list-style-type: none"> <li>• Stepper motor not moving freely or blocked</li> <li>• Encoder cable not connected or defective</li> <li>• Stepper motor cable not connected or defective</li> <li>• Encoder defective</li> <li>• Stepper motor faulty</li> </ul>	<ul style="list-style-type: none"> <li>• Remove the cause of the stiff movement or blockage</li> <li>• Check the encoder cable and replace, if necessary</li> <li>• Replace encoder</li> </ul> If the stepper motor is not supplied with current: <ul style="list-style-type: none"> <li>• Check the stepper motor cable and replace, if necessary</li> <li>• Replace stepper motor</li> </ul>
2303	Error	Z-axis stepper motor step losses: <ul style="list-style-type: none"> <li>• Stiff mechanical movement or blockage</li> </ul>	<ul style="list-style-type: none"> <li>• Remove the cause of the stiff mechanical movement or blockage</li> </ul>
2321	Error	Z-axis stepper motor: <ul style="list-style-type: none"> <li>• Encoder plug (Sub-D, 9-pin) not connected or defective</li> <li>• Encoder defective</li> </ul>	<ul style="list-style-type: none"> <li>• Check the connection of the encoder cable and replace, if necessary</li> </ul>
2322	Information	Pulse wheel search time out	<ul style="list-style-type: none"> <li>• Check connection cables</li> <li>• Check stepper motor for stiff movement</li> </ul>
2330	Error	Z-axis stepper motor not responding	<ul style="list-style-type: none"> <li>• Perform a software update</li> <li>• Replace control</li> </ul>
2352	Error	Z-axis stepper motor overcurrent	<ul style="list-style-type: none"> <li>• Replace stepper motor</li> </ul>
2353	Error	Overvoltage	<ul style="list-style-type: none"> <li>• Check mains voltage</li> </ul>
2355	Error	Z-axis stepper motor overload ( $I^2T$ ): <ul style="list-style-type: none"> <li>• Stepper motor not moving freely or blocked</li> <li>• Stepper motor faulty</li> <li>• Control defective</li> </ul>	<ul style="list-style-type: none"> <li>• Remove the blockage or the cause of the stiff movement</li> <li>• Replace stepper motor</li> <li>• Replace control</li> </ul>

Code	Type	Possible causes	Remedial action
2356	Error	Z-axis stepper motor: <ul style="list-style-type: none"> <li>• Stepper motor sluggish</li> <li>• Stepper motor faulty</li> <li>• Control defective</li> </ul>	<ul style="list-style-type: none"> <li>• Eliminate sluggishness</li> <li>• Replace stepper motor</li> <li>• Replace control</li> </ul>
2362	Error	Z-axis stepper motor disturbance (IDMA auto increment)	<ul style="list-style-type: none"> <li>• Switch off and on the machine</li> </ul>
2371	Error	Watchdog	<ul style="list-style-type: none"> <li>• Switch off and on the machine</li> <li>• Perform a software update</li> <li>• Contact customer service</li> </ul>
2372	Error	Stepper motor overvoltage: <ul style="list-style-type: none"> <li>• Stepper motor card defective</li> </ul>	<ul style="list-style-type: none"> <li>• Replace control</li> </ul>
2373	Error	Z-axis stepper motor error	<ul style="list-style-type: none"> <li>• Check the connection</li> <li>• Test stepper motor phases (R = 2.8Ω, high impedance to PE)</li> <li>• Replace encoder</li> <li>• Replace stepper motor</li> <li>• Replace control</li> </ul>
2374	Error	Software error	<ul style="list-style-type: none"> <li>• Perform reset</li> <li>• Perform a software update</li> <li>• Contact customer service</li> </ul>
2375	Error	Magnet wheel search	<ul style="list-style-type: none"> <li>• Check the connection</li> <li>• Test stepper motor phases (R = 2.8Ω, high impedance to PE)</li> <li>• Replace encoder</li> <li>• Replace stepper motor</li> <li>• Replace control</li> </ul>
2377	Error	Stepper motor overload (I <sup>2</sup> T)	<ul style="list-style-type: none"> <li>• Remove the cause of the stiff movement or blockage</li> <li>• Replace stepper motor</li> <li>• Replace control</li> </ul>
2378	Error	Encoder error	<ul style="list-style-type: none"> <li>• Check the connection of the encoder cable and replace, if necessary</li> <li>• Replace control</li> </ul>
2379	Error	Current sensor: <ul style="list-style-type: none"> <li>• Stepper motor card defective</li> <li>• Control defective</li> </ul>	<ul style="list-style-type: none"> <li>• Replace control</li> </ul>
2380	Error	Direction	<ul style="list-style-type: none"> <li>• Replace encoder</li> <li>• Check plug assignment and change, if necessary</li> <li>• Check wiring in machine distributor and change it, if necessary</li> <li>• Test stepper motor phases and check for correct value</li> </ul>
2381	Error	Error in the reference run	<ul style="list-style-type: none"> <li>• Replace reference switch</li> </ul>
2382	Error	Stepper motor current error	<ul style="list-style-type: none"> <li>• Remove blockage</li> <li>• Check the encoder cable and replace, if necessary</li> <li>• Replace stepper motor</li> </ul>

Code	Type	Possible causes	Remedial action
2383	Error	Stepper motor overcurrent	<ul style="list-style-type: none"> <li>• Replace sewing motor cable</li> <li>• Replace stepper motor</li> <li>• Replace control</li> </ul>
2384	Error	Software error	<ul style="list-style-type: none"> <li>• Perform reset</li> <li>• Perform a software update</li> <li>• Contact customer service</li> </ul>
2385	Error	Stepper motor insulation error	<ul style="list-style-type: none"> <li>• Check motor phase and PE for low-impedance connection</li> <li>• Replace encoder</li> <li>• Replace stepper motor</li> </ul>
2386	Error	Software error	<ul style="list-style-type: none"> <li>• Perform reset</li> <li>• Perform a software update</li> <li>• Contact customer service</li> </ul>
2387	Error	Software error	<ul style="list-style-type: none"> <li>• Perform reset</li> <li>• Perform a software update</li> <li>• Contact customer service</li> </ul>
2388	Error	Software error	<ul style="list-style-type: none"> <li>• Perform reset</li> <li>• Perform a software update</li> <li>• Contact customer service</li> </ul>
2402	Error	U-axis stepper motor: <ul style="list-style-type: none"> <li>• Stepper motor not moving freely or blocked</li> <li>• Encoder cable not connected or defective</li> <li>• Stepper motor cable not connected or defective</li> <li>• Encoder defective</li> <li>• Stepper motor faulty</li> </ul>	<ul style="list-style-type: none"> <li>• Remove the cause of the stiff movement or blockage</li> <li>• Check the encoder cable and replace, if necessary</li> <li>• Replace encoder</li> </ul> If the stepper motor is not supplied with current: <ul style="list-style-type: none"> <li>• Check the stepper motor cable and replace, if necessary</li> <li>• Replace stepper motor</li> </ul>
2403	Error	U-axis stepper motor step losses: <ul style="list-style-type: none"> <li>• Stiff mechanical movement or blockage</li> </ul>	<ul style="list-style-type: none"> <li>• Remove the cause of the stiff mechanical movement or blockage</li> </ul>
2421	Error	U-axis stepper motor: <ul style="list-style-type: none"> <li>• Encoder plug (Sub-D, 9-pin) not connected or defective</li> <li>• Encoder defective</li> </ul>	<ul style="list-style-type: none"> <li>• Check the connection of the encoder cable and replace, if necessary</li> </ul>
2422	Information	Pulse wheel search time out	<ul style="list-style-type: none"> <li>• Check connection cables</li> <li>• Check stepper motor for stiff movement</li> </ul>
2430	Error	U-axis stepper motor not responding	<ul style="list-style-type: none"> <li>• Perform a software update</li> <li>• Replace control</li> </ul>
2452	Error	U-axis stepper motor over current	<ul style="list-style-type: none"> <li>• Replace stepper motor</li> </ul>
2453	Error	Overvoltage	<ul style="list-style-type: none"> <li>• Check mains voltage</li> </ul>










Code	Type	Possible causes	Remedial action
2455	Error	U-axis stepper motor overload (I <sup>2</sup> T): <ul style="list-style-type: none"> <li>• Stepper motor not moving freely or blocked</li> <li>• Stepper motor faulty</li> <li>• Control defective</li> </ul>	<ul style="list-style-type: none"> <li>• Remove the blockage or the cause of the stiff movement</li> <li>• Replace stepper motor</li> <li>• Replace control</li> </ul>
2456	Error	U-axis stepper motor: <ul style="list-style-type: none"> <li>• Stepper motor sluggish</li> <li>• Stepper motor faulty</li> <li>• Control defective</li> </ul>	<ul style="list-style-type: none"> <li>• Eliminate sluggishness</li> <li>• Replace stepper motor</li> <li>• Replace control</li> </ul>
2462	Error	<ul style="list-style-type: none"> <li>• U-axis stepper motor disturbance (IDMA auto increment)</li> </ul>	<ul style="list-style-type: none"> <li>• Switch off and on the machine</li> </ul>
2471	Error	<ul style="list-style-type: none"> <li>• Watchdog</li> </ul>	<ul style="list-style-type: none"> <li>• Switch off and on the machine</li> <li>• Perform a software update</li> <li>• Contact customer service</li> </ul>
2472	Error	Stepper motor overvoltage: <ul style="list-style-type: none"> <li>• Stepper motor card defective</li> </ul>	<ul style="list-style-type: none"> <li>• Replace control</li> </ul>
2473	Error	U-axis stepper motor over current error	<ul style="list-style-type: none"> <li>• Check the connection</li> <li>• Test stepper motor phases (R = 2.8Ω, high impedance to PE)</li> <li>• Replace encoder</li> <li>• Replace stepper motor</li> <li>• Replace control</li> </ul>
2474	Error	Software error	<ul style="list-style-type: none"> <li>• Perform reset</li> <li>• Perform a software update</li> <li>• Contact customer service</li> </ul>
2475	Error	Magnet wheel search	<ul style="list-style-type: none"> <li>• Check the connection</li> <li>• Test stepper motor phases (R = 2.8Ω, high impedance to PE)</li> <li>• Replace encoder</li> <li>• Replace stepper motor</li> <li>• Replace control</li> </ul>
2477	Error	Stepper motor overload (I <sup>2</sup> T)	<ul style="list-style-type: none"> <li>• Remove the cause of the stiff movement or blockage</li> <li>• Replace stepper motor</li> <li>• Replace control</li> </ul>
2478	Error	Encoder error	<ul style="list-style-type: none"> <li>• Check the connection of the encoder cable and replace, if necessary</li> <li>• Replace control</li> </ul>
2479	Error	Current sensor: <ul style="list-style-type: none"> <li>• Stepper motor card defective</li> <li>• Control defective</li> </ul>	<ul style="list-style-type: none"> <li>• Replace control</li> </ul>
2480	Error	Direction	<ul style="list-style-type: none"> <li>• Replace encoder</li> <li>• Check plug assignment and change, if necessary</li> <li>• Check wiring in machine distributor and change it, if necessary</li> <li>• Test stepper motor phases and check for correct value</li> </ul>

Code	Type	Possible causes	Remedial action
2481	Error	Error in the reference run	<ul style="list-style-type: none"> <li>• Replace reference switch</li> </ul>
2482	Error	Stepper motor current error	<ul style="list-style-type: none"> <li>• Remove blockage</li> <li>• Check the encoder cable and replace, if necessary</li> <li>• Replace stepper motor</li> </ul>
2483	Error	Stepper motor overcurrent	<ul style="list-style-type: none"> <li>• Replace sewing motor cable</li> <li>• Replace stepper motor</li> <li>• Replace control</li> </ul>
2484	Error	Software error	<ul style="list-style-type: none"> <li>• Perform reset</li> <li>• Perform a software update</li> <li>• Contact customer service</li> </ul>
2485	Error	Stepper motor insulation error	<ul style="list-style-type: none"> <li>• Check motor phase and PE for low-impedance connection</li> <li>• Replace encoder</li> <li>• Replace stepper motor</li> </ul>
2486	Error	Software error	<ul style="list-style-type: none"> <li>• Perform reset</li> <li>• Perform a software update</li> <li>• Contact customer service</li> </ul>
2487	Error	Software error	<ul style="list-style-type: none"> <li>• Perform reset</li> <li>• Perform a software update</li> <li>• Contact customer service</li> </ul>
2488	Error	Software error	<ul style="list-style-type: none"> <li>• Perform reset</li> <li>• Perform a software update</li> <li>• Contact customer service</li> </ul>
2901	Error	Referencing timeout	<ul style="list-style-type: none"> <li>• Switch off and on the machine</li> <li>• Check the clamping of the stepper motor</li> </ul>
3010	Error	Control: 100 V voltage error	<ul style="list-style-type: none"> <li>• Check connections</li> <li>• Replace control</li> </ul>
3011	Error	Control: 100 V voltage error	<ul style="list-style-type: none"> <li>• Check connections</li> <li>• Replace control</li> </ul>
3012	Error	Control: 100 V voltage error (I <sup>2</sup> T)	<ul style="list-style-type: none"> <li>• Switch off and on the machine</li> <li>• Check connections</li> <li>• Replace control</li> </ul>
3020	Error	Short circuit at input or output 24 V	<ul style="list-style-type: none"> <li>• Check connections</li> <li>• Replace control</li> </ul>
3021	Error	Short circuit at input or output 24 V	<ul style="list-style-type: none"> <li>• Check connections</li> <li>• Replace control</li> </ul>
3022	Error	Short circuit in 24 V input or output (I <sup>2</sup> T)	<ul style="list-style-type: none"> <li>• Switch off and on the machine</li> <li>• Check connections</li> <li>• Replace control</li> </ul>
3030	Error	Sewing motor phase error	<ul style="list-style-type: none"> <li>• Test sewing motor phases (R = 2.8Ω, high impedance to PE)</li> <li>• Replace encoder</li> <li>• Replace sewing motor</li> <li>• Replace control</li> </ul>



Code	Type	Possible causes	Remedial action
3104	Warning	<ul style="list-style-type: none"> <li>• Foot pedal not in rest position</li> <li>• Setpoint device defective</li> </ul>	<ul style="list-style-type: none"> <li>• Do not step on the foot pedal when starting up the machine</li> <li>• Replace setpoint device</li> </ul>
4440 – 4459	Error	OP3000 control panel: Internal error	<ul style="list-style-type: none"> <li>• Switch off and on the machine</li> <li>• Perform a software update</li> <li>• Replace control panel</li> </ul>
5503	Error	Software too old	<ul style="list-style-type: none"> <li>• Perform a software update followed by a reset (📖 p. 88), (📖 p. 109)</li> </ul>
6000 – 6299	Error	Internal error	<ul style="list-style-type: none"> <li>• Switch off and on the machine</li> <li>• Perform a software update</li> <li>• Contact customer service</li> </ul>
6351 – 6354	Error	Control defective (I <sup>2</sup> C)	<ul style="list-style-type: none"> <li>• Replace control</li> </ul>
6360 – 6367	Error	Machine ID error	<ul style="list-style-type: none"> <li>• Check the machine ID plug</li> <li>• If necessary, replace the machine ID</li> </ul>
6400 – 6999	Error	Internal error	<ul style="list-style-type: none"> <li>• Switch off and on the machine</li> <li>• Perform a software update</li> <li>• Contact customer service</li> </ul>
7551 – 7659	Error	<ul style="list-style-type: none"> <li>• Internal error</li> <li>• Cable disturbance</li> <li>• Cables to the control panel interface defective</li> </ul>	<ul style="list-style-type: none"> <li>• Switch off and on the machine</li> <li>• Eliminate source of disturbance</li> <li>• Perform a software update</li> <li>• Replace cable</li> <li>• Contact customer service</li> </ul>
9910	Error	Tilt sensor: <ul style="list-style-type: none"> <li>• Machine head is tilted over</li> <li>• Tilt sensor not assembled or defective</li> </ul>	<ul style="list-style-type: none"> <li>• Erect the machine head</li> <li>• Assemble or replace tilt sensor</li> </ul>

### 19.3 Errors in sewing process

Meaning	Possible causes	Remedial action
Thread breaking	<ul style="list-style-type: none"> <li>Needle thread and hook thread have not been threaded correctly</li> </ul>	<ul style="list-style-type: none"> <li>Check threading path ( <i>Operating Instructions, Operation</i>)</li> </ul>
	<ul style="list-style-type: none"> <li>Needle is bent or sharp-edged</li> <li>Needle is not inserted correctly into the needle bar</li> </ul>	<ul style="list-style-type: none"> <li>Replace needle</li> <li>Insert the needle into the needle bar</li> </ul>
	<ul style="list-style-type: none"> <li>The thread used is unsuitable</li> </ul>	<ul style="list-style-type: none"> <li>Use recommended thread ( <i>Operating Instructions</i>)</li> </ul>
	<ul style="list-style-type: none"> <li>Thread tensions are too tight for the thread used</li> </ul>	<ul style="list-style-type: none"> <li>Check thread tensions ( <i>Operating Instructions, Operation</i>)</li> </ul>
	<ul style="list-style-type: none"> <li>Thread-guiding parts such as thread tube, thread guide or thread-takeup disk are sharp-edged</li> </ul>	<ul style="list-style-type: none"> <li>Check the thread path</li> </ul>
	<ul style="list-style-type: none"> <li>Throat plate, hook or spread have been damaged by the needle</li> </ul>	<ul style="list-style-type: none"> <li>Have parts reworked by qualified specialists</li> </ul>
Skip stitches	<ul style="list-style-type: none"> <li>Needle thread and hook thread have not been threaded correctly</li> </ul>	<ul style="list-style-type: none"> <li>Check threading path ( <i>Operating Instructions, Operation</i>)</li> </ul>
	<ul style="list-style-type: none"> <li>Needle is blunt or bent</li> <li>Needle is not inserted correctly into the needle bar</li> </ul>	<ul style="list-style-type: none"> <li>Replace needle</li> <li>Insert the needle into the needle bar</li> </ul>
	<ul style="list-style-type: none"> <li>The needle strength used is unsuitable</li> </ul>	<ul style="list-style-type: none"> <li>Use recommended needle strength ( p. 139)</li> </ul>
	<ul style="list-style-type: none"> <li>The reel stand is assembled incorrectly</li> </ul>	<ul style="list-style-type: none"> <li>Check reel stand ( <i>Operating Instructions, Setup</i>)</li> </ul>
	<ul style="list-style-type: none"> <li>Thread tensions are too tight</li> </ul>	<ul style="list-style-type: none"> <li>Check thread tensions ( <i>Operating Instructions, Operation</i>)</li> </ul>
	<ul style="list-style-type: none"> <li>Sewing material is not held correctly</li> </ul>	<ul style="list-style-type: none"> <li>Check clamping pressure ( p. 57)</li> </ul>
	<ul style="list-style-type: none"> <li>The loop stroke was not corrected when changing the zigzag stitch width</li> </ul>	<ul style="list-style-type: none"> <li>Set the loop stroke ( p. 24)</li> </ul>
	<ul style="list-style-type: none"> <li>Incorrect parts used for the desired sewing equipment</li> </ul>	<ul style="list-style-type: none"> <li>Check the parts based on the equipment sheet</li> </ul>
	<ul style="list-style-type: none"> <li>Throat plate, hook or spread have been damaged by the needle</li> </ul>	<ul style="list-style-type: none"> <li>Have parts reworked by qualified specialists</li> </ul>

Meaning	Possible causes	Remedial action
Loose stitches	<ul style="list-style-type: none"> <li>• Thread tensions are not adjusted to the sewing material, the sewing material thickness or the thread used</li> </ul>	<ul style="list-style-type: none"> <li>• Check thread tensions</li> </ul>
	<ul style="list-style-type: none"> <li>• Needle thread and hook thread have not been threaded correctly</li> </ul>	<ul style="list-style-type: none"> <li>• Check threading path (📖 <i>Operating Instructions, Operation</i>)</li> </ul>
Needle breakage	<ul style="list-style-type: none"> <li>• Needle strength is unsuitable for the sewing material or the thread</li> </ul>	<ul style="list-style-type: none"> <li>• Use recommended needle</li> </ul>
Seam beginning not secure	<ul style="list-style-type: none"> <li>• Residual tension is too tight for the needle thread</li> </ul>	<ul style="list-style-type: none"> <li>• Adjust residual tension</li> </ul>



## 20 Technical data

### Noise emission

Workplace-specific emission value as per DIN EN ISO 10821:

$L_c = 79$  dB (A) at

- Stitch length: 3.0 mm
- Number of stitches: 2900 rpm
- Sewing material: 2-layer material G1 DIN 23328

### 20.1 Data and characteristic values

Technical data	Unit	650-10
Machine type		Special sewing machine
Type of stitches		Double lockstitch 301
Hook type		Horizontal hook, oil-free
Number of needles		1
Needle system		134-35
Needle strength	[Nm]	70 – 100
Thread strength	[Nm]	max. 50 / 3
Stitch length	[mm]	1.0 – 4.0
Max. speed	[min <sup>-1</sup> ]	4000
Clearance under the raised sewing foot	[mm]	max. 12
Sewing material thickness	[mm]	max. 4
Mains voltage	[V]	230
Mains frequency	[Hz]	50
Table height	[mm]	750 – 900
Length, width, height	[mm]	750/1320/1490
Weight	[kg]	95

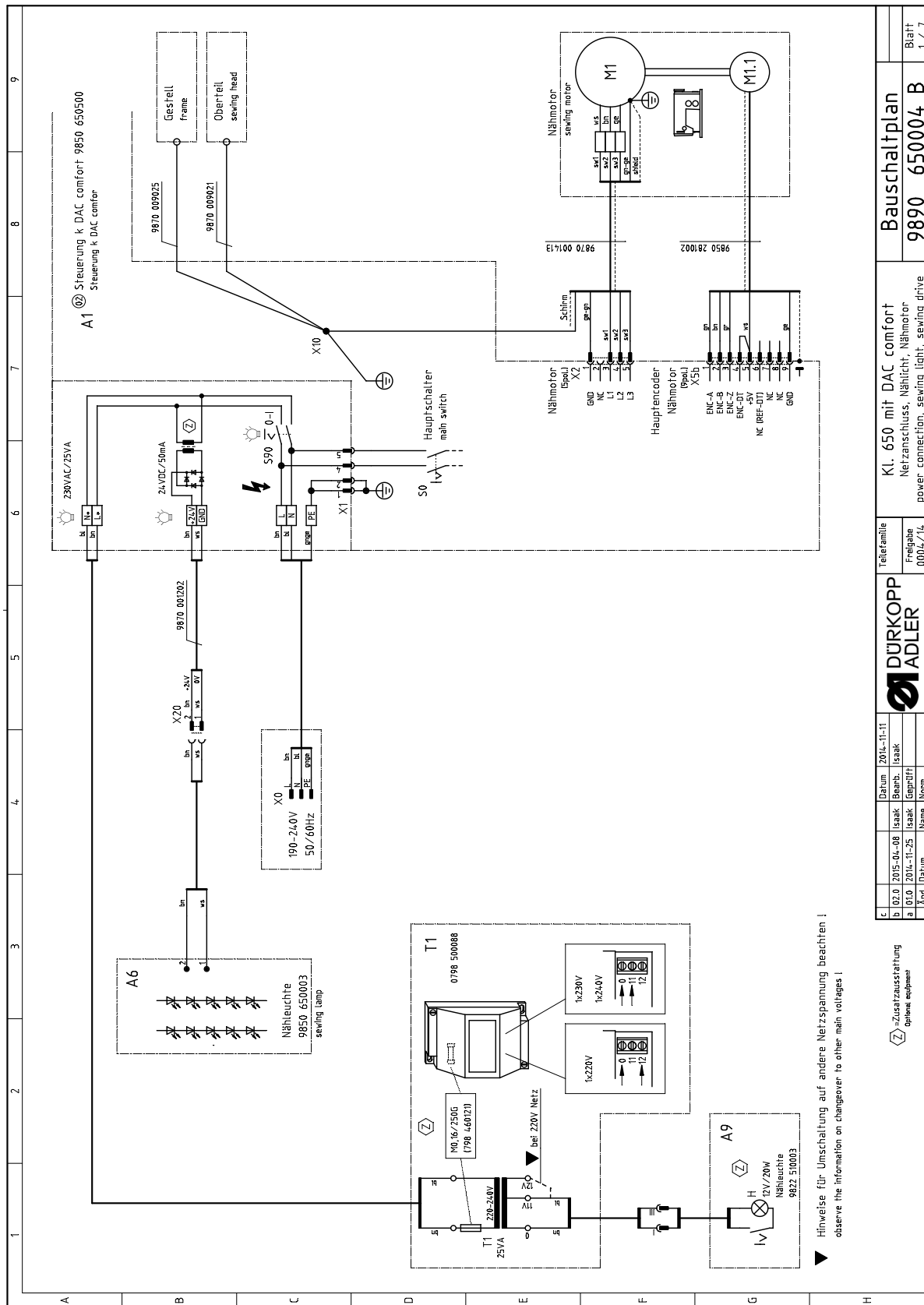
### 20.2 Requirements for fault-free operation

Compressed air quality must conform to ISO 8573-1: 2010 [7:4:4].



# 21 Appendix

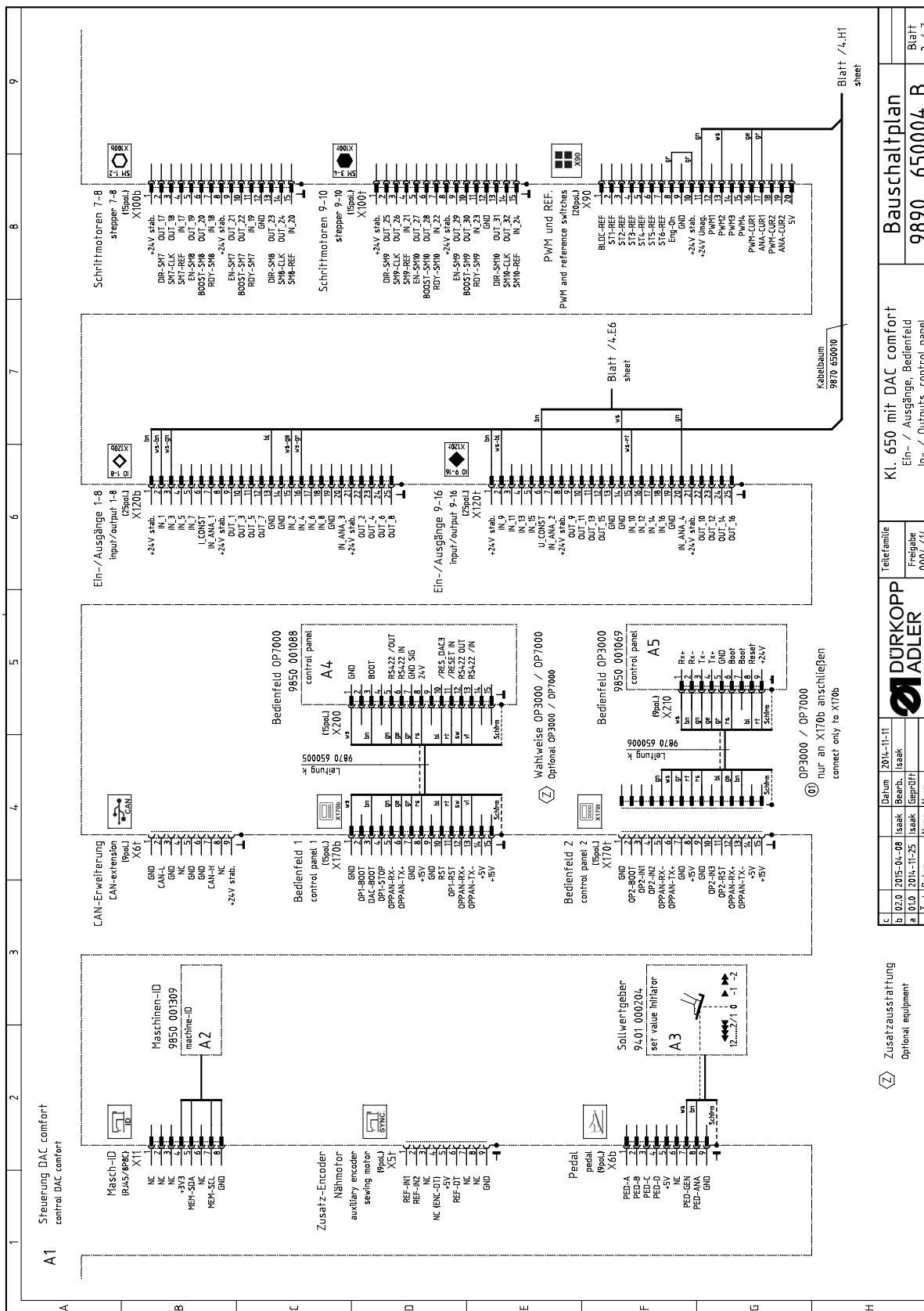
Fig. 88: Wiring diagram,



▶ Hinweise für Umschaltung auf andere Netzspannung beachten !  
 observe the information on changeover to other main voltages !

Teilfamilie		Datum		Blatt	
Freigabe		2016-11-11		1 / 7	
0004/14		Isak		Bauschaltplan	
		Isak		9890 650004 B	
		Name		Kl. 650 mit DAC comfort	
		Norm		Netzanschluss, Nählicht, Nähmotor	
				power connection, sewing light, sewing drive	

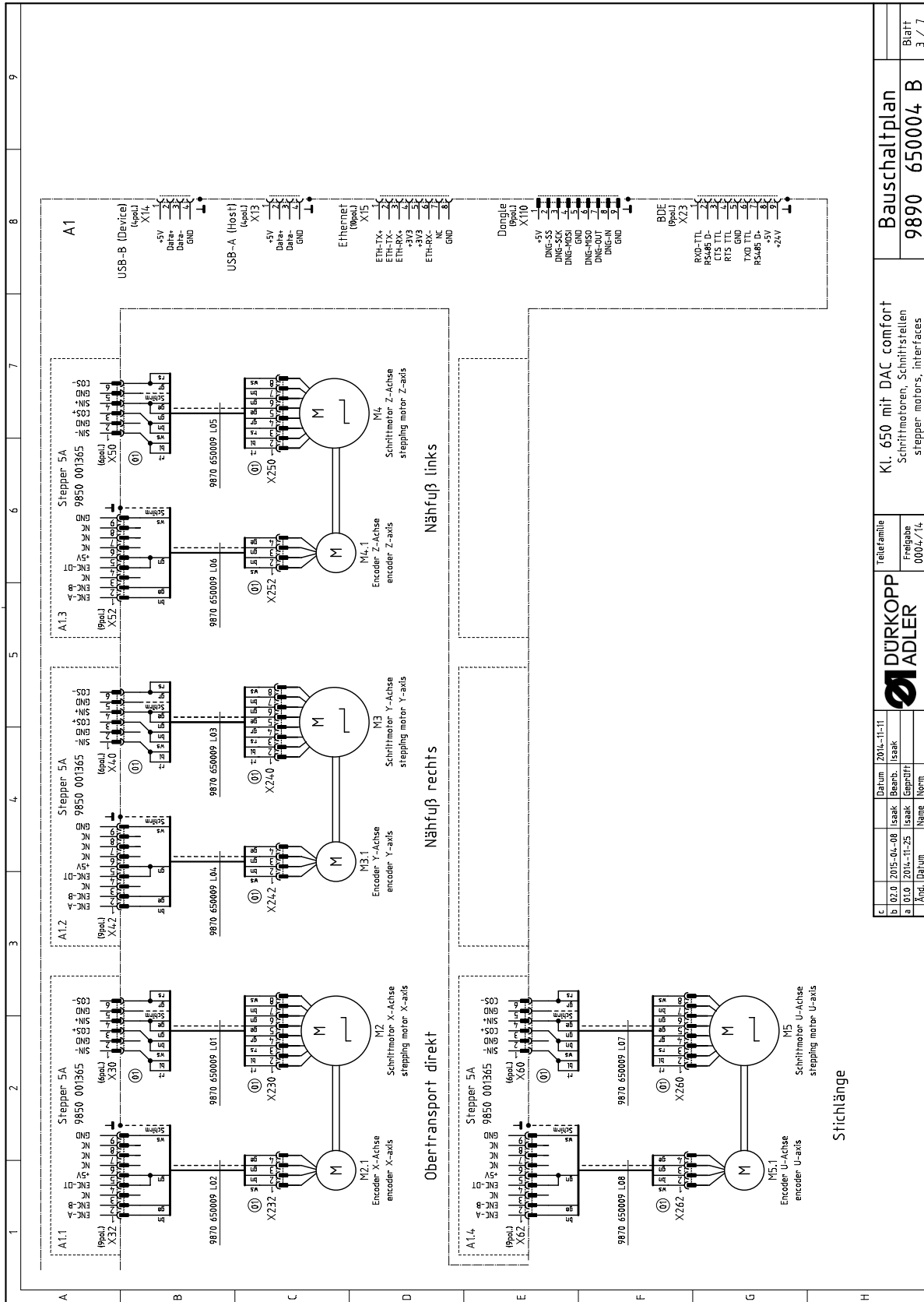
Fig. 89: Wiring diagram



Blatt / 4, H1 sheet	
Bauschaltplan 9890 650004 B	
Kl. 650 mit DAC comfort Ein- / Ausgänge, Bedienfeld In- / Outputs, control panel	
Telefamilie Freigabe 0004/14	DÜRKOPP ADLER
c	Datum 2014-11-11
b	02.0 2015-04-08
a	01.0 2014-11-25
Änd.	Datum
Name	Norm
Zusatzausstattung Optional equipment	



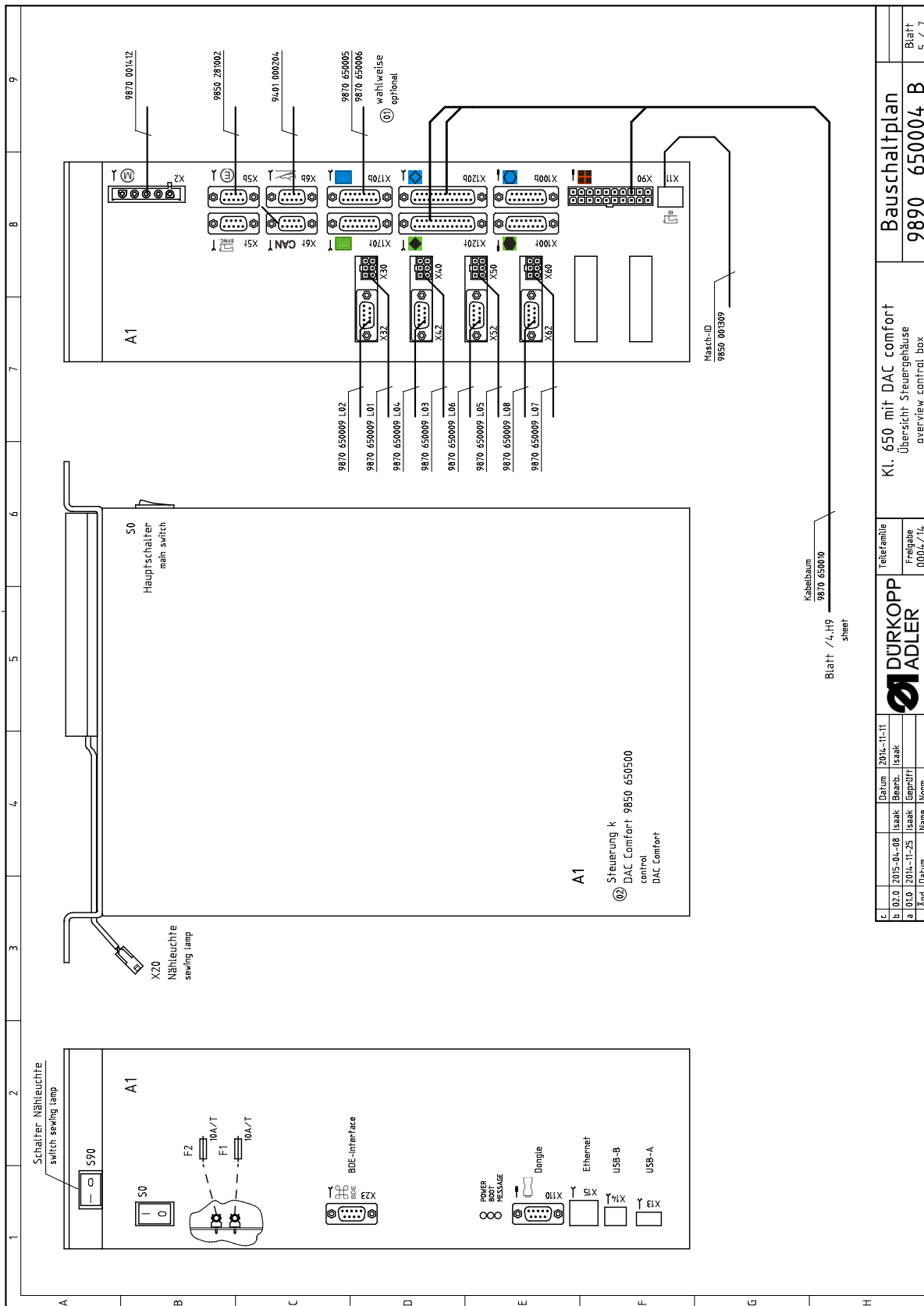
Fig. 90: Wiring diagram



<b>Bauschaltplan</b> 9890 650004 B		Blatt 3 / 7	
<b>DÜRKOPP ADLER</b>		Teilerfamilie Kl. 650 mit DAC comfort Schrittmotoren, Schnittstellen stepper motors, interfaces	
Datum: 2015-11-11 Bearb.: Isack		Freigabe 0004/714	
02.0 2015-01-08 01.0 2015-11-25		Name: Isack Norm: Geprüftr	
1. Aufl. Datum		Name: Norm	



Fig. 92: Wiring diagram



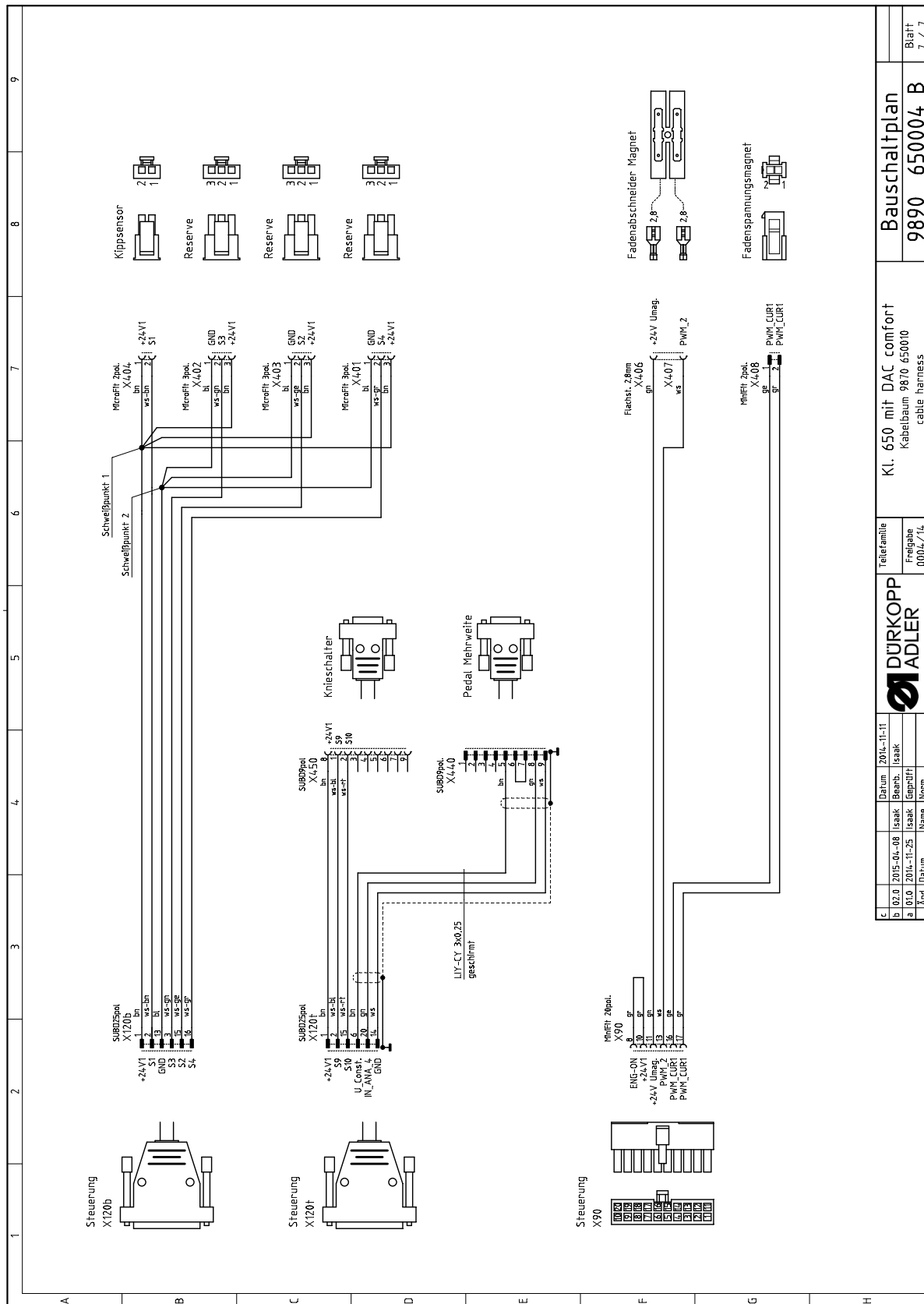
Teilfamilie		Kl. 650 mit DAC comfort Übersicht Steuerunghäuse overview control box		Bauschaltplan 9890 650004 B		Blatt 5 / 7	
Datum		2015-11-11		DÜRKOPP ADLER		Freigabe 0004/714	
Isaak		Isaak		Isaak		Isaak	
Name		Norm		Name		Norm	

Fig. 93: Wiring diagram

Kurzzeichen	Teilenummer	Benennung	denomination	Typ	Bemerkung
A1	9850 650500	Steuerung k	control	COMFORT;TYP:111100	
A2	9850 001355	USB-Speicherstick	USB memory stick	Softw. DAC comfort	
A3	9850 001309	Maschinen ID	machine ID		
A4	9401 000204	Sollwertgeber	actuator	OP7000	
A5	9850 001088	Bedienfeld k	control panel	OP3000	
A6	9850 001069	Bedienfeld k	control panel	15-LED Nähleuchte	
A7	9850 650003	Leiterplatte k	PCB cpl.		
A8	9880 002005	Knieschalter	knee switch	SWG-2	Pedal Mehrweite
A9	9800 350002	Sollwertgeber	actuator	12V/20W Halogen	(on request / auf Wunsch)
A9	9822 510003	Nähleuchte	sewing light		
M1.1	9850 281002	Encoder k	encoder cpl.		(nur montiert lieferbar / only mounted available)
M2	9800 580033	Stepper X-Achse	stepper x-axis	Obertransport	
M2.1	0580 490194	Encoder X-Achse	encoder cpl.		
M3	9800 580042	Stepper Y-Achse	stepper x-axis	Nähfuß rechts	(nur montiert lieferbar / only mounted available)
M3.1	0580 490194	Encoder Y-Achse	encoder cpl.		
M4	9800 580042	Stepper Z-Achse	stepper x-axis	Nähfuß links	(nur montiert lieferbar / only mounted available)
M4.1	0580 490194	Encoder Z-Achse	encoder cpl.		
M5	9800 580033	Stepper U-Achse	stepper x-axis	Obertransport	(nur montiert lieferbar / only mounted available)
M5.1	0580 490194	Encoder U-Achse	encoder cpl.		
S1	9815 550002	Schalter, Magnet k	magnetic switch	Kippsensor	
T1	0798 500088	Trafo, Nählicht	transf. sewing light	230V AC / 12V AC	(on request / auf Wunsch)
X0	9825 190104	Netzstecker	mains plug	Schuko (DE)	(on request / auf Wunsch)
Y101	0281 350154	FA-Magnet	trimmer solenoid		
Y102	9820 110035	FS-Magnet	thread tension solenoid		

		Teilenummer: 9850 650500 Freigabe: 0004/14	Teilfamilie: Kl. 650 mit DAC comfort Teileliste: parts list	Bauschaltplan 9890 650004 B	Blatt 6 / 7
--	--	---	--	--------------------------------	----------------

Fig. 94: Wiring diagram







DÜRKOPP ADLER GmbH

Potsdamer Straße 190

33719 Bielefeld

GERMANY

Phone +49 (0) 521 / 925-00

E-mail [service@duerkopp-adler.com](mailto:service@duerkopp-adler.com)

[www.duerkopp-adler.com](http://www.duerkopp-adler.com)

