

911

## Additional Instructions

# Slideway lining for the tabletop

**IMPORTANT**  
**READ CAREFULLY BEFORE USE**  
**KEEP FOR FUTURE REFERENCE**

All rights reserved.

Property of Dürkopp Adler GmbH and protected by copyright. Any reuse of these contents, including extracts, is prohibited without the prior written approval of Dürkopp Adler GmbH.

Copyright © Dürkopp Adler GmbH 2020

<b>1</b>	<b>About these additional instructions .....</b>	<b>3</b>
<b>2</b>	<b>Components of the kit.....</b>	<b>4</b>
<b>3</b>	<b>Attaching the slideway lining to the tabletop .....</b>	<b>5</b>
<b>4</b>	<b>Appendix .....</b>	<b>6</b>



## 1 About these additional instructions

These additional instructions describe how to attach the slideway lining for the tabletop to machines grouped in the 911 class.



### **Important**

The slideway lining for the tabletop is 1.5 mm thick.

Before attaching the slideway lining, you need to shift the height of the machine head by 1.5 mm and realign the machine head ( *Service Instructions*).

## 2 Components of the kit

Check whether the scope of delivery for the kit is correct prior to attaching the slideway lining.

Different kits are available that vary with the size of the sewing field. The installation procedure is the same for all kits.

Kit	0911 597834	0911 597844	0911 597845	0911 597864
Sewing field size	3020	6055	2010	6020
Plate	0911 400724	0911 400754	0911 400694	0911 400774
Double sided adhesive tape	B760 200015			
Additional Instructions	0791 911714 EN			

### 3 Attaching the slideway lining to the tabletop

Fig. 1: Attaching the slideway lining to the tabletop

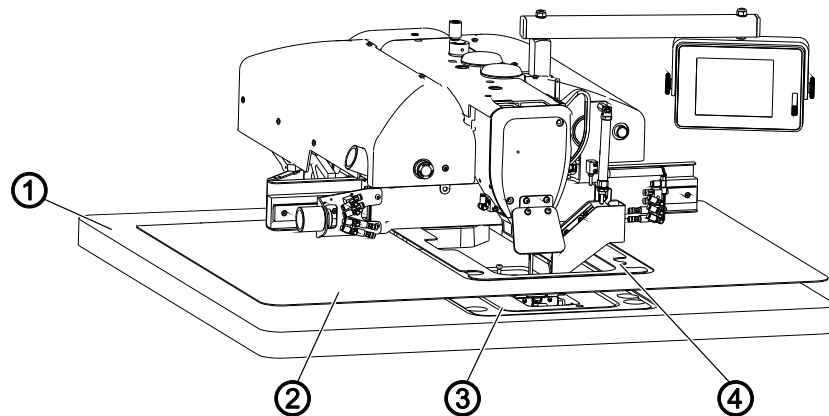

(1) - Tabletop



(2) - Slideway lining

(3) - Tabletop cut-out

(4) - Inner insert of the slideway lining



To attach the slideway lining:

1. Remove the sliding plate (not shown).
2. Affix the double-sided adhesive tape on the underside of the slideway lining (2) and peel off the protective film from the tape (see **Appendix** ( p. 6)).
3. Align the slideway lining (2) flush with the tabletop (1) and apply it.
4. Bond the inner insertion plate of the slideway lining (4) into the tabletop cut-out (3).
5. Reinsert the sliding plate.
6. Align the height of the machine head ( *Service Instructions*).

## 4 Appendix

### Positions for double sided adhesive tape at the bottom side of the slideway lining

Abb. 2: Sewing field size 2010



Abb. 3: Sewing field size 3020





Abb. 4: Sewing field size 6020

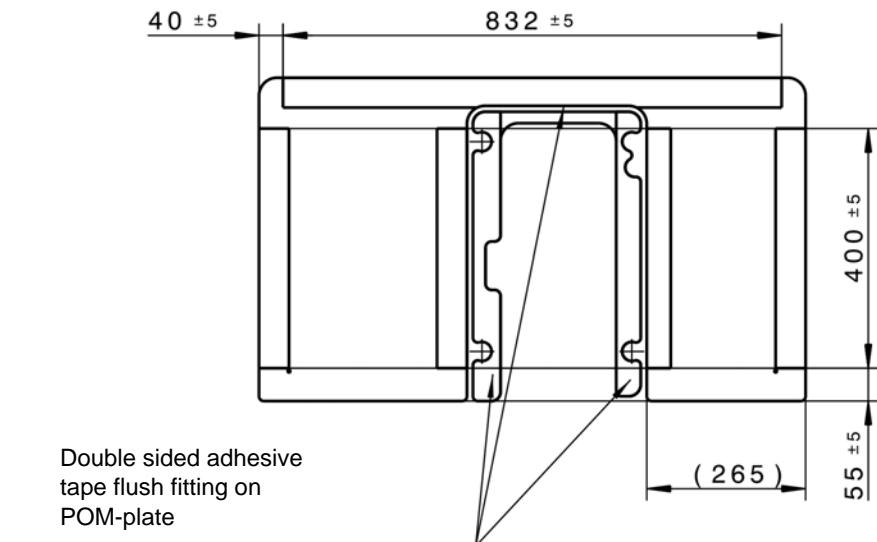

Abb. 5: Sewing field size 6055

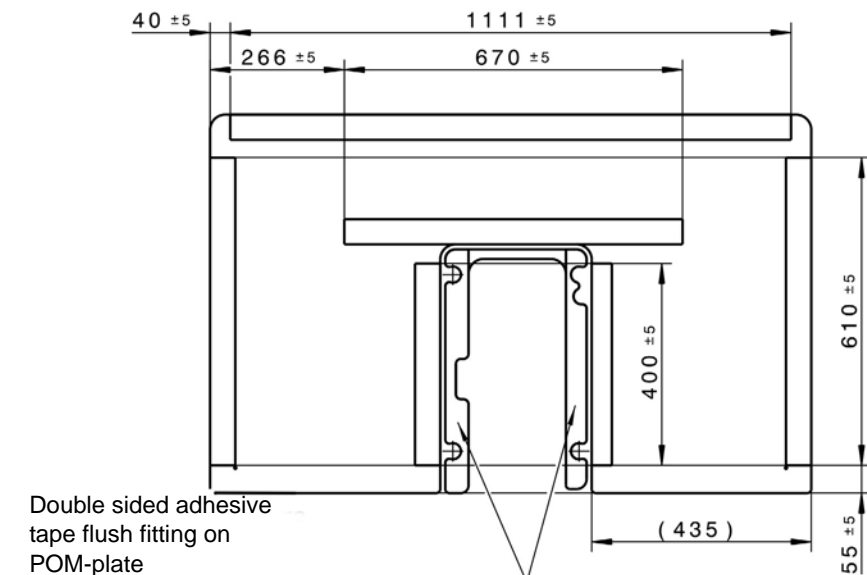





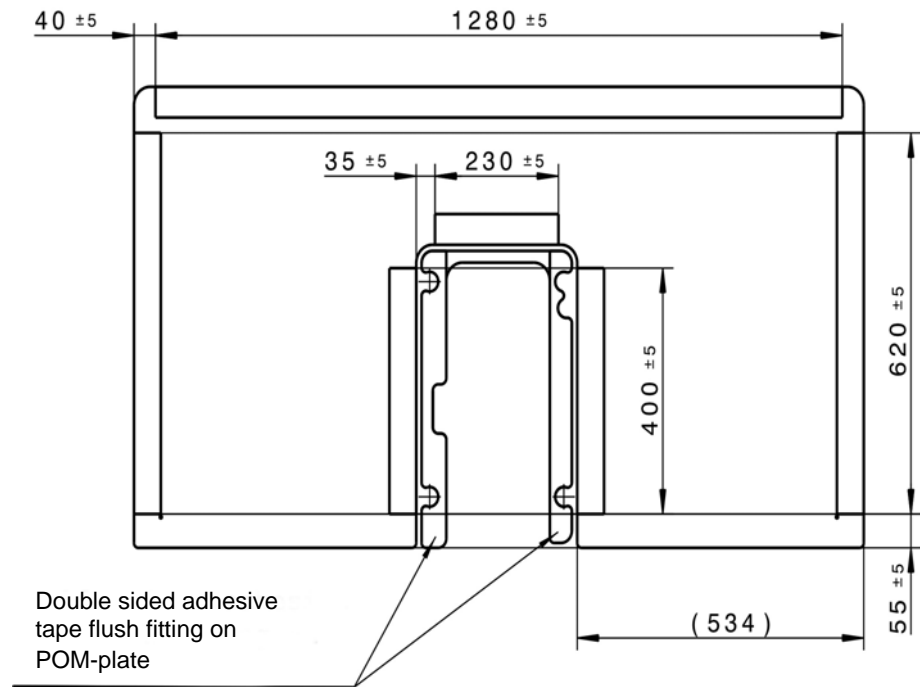
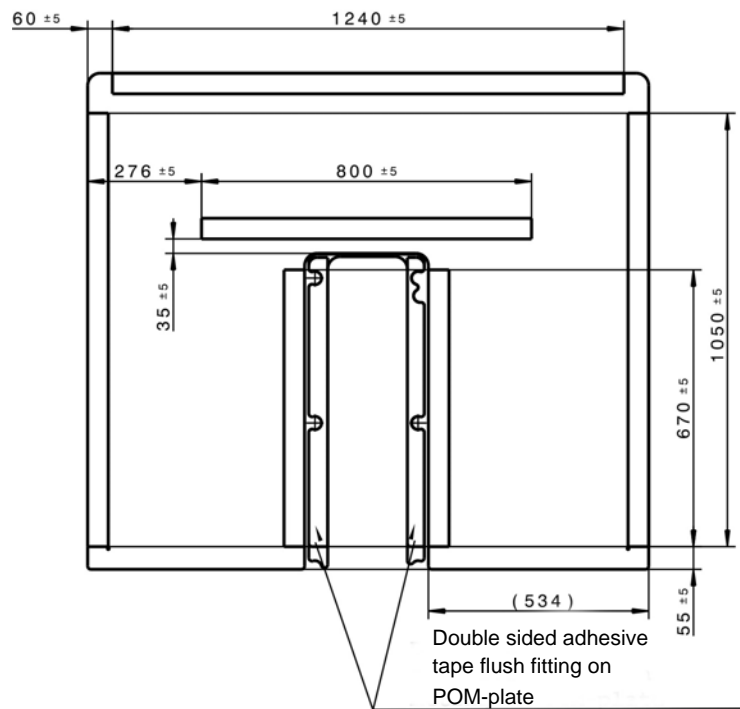

DÜRKOPP ADLER GmbH  
Potsdamer Str. 190  
33719 Bielefeld  
Germany  
Phone: +49 (0) 521 925 00  
Email: [service@duerkopp-adler.com](mailto:service@duerkopp-adler.com)  
[www.duerkopp-adler.com](http://www.duerkopp-adler.com)